



Stantec Consulting Ltd.  
300W-675 Cochrane Drive, Markham ON L3R 0B8

March 1, 2021  
File: 160960844

**Attention: Luanne Patterson, Sr. System Manager – EA Environment**  
Canadian National Railway Company  
Box 8100  
Montreal, QC H3C 3N4

Dear Ms. Patterson,

**Reference: Preliminary Dewatering Plan for Milton Logistics Hub Lower Base Line Grade Separation Construction, Milton, ON**

Canadian National Railway Company (CN) is preparing to advance the construction of the road / rail grade separation along Lower Base Line, within the Project Development Area (PDA) of the Milton Logistics Hub (the Project) in the Town of Milton. CN has retained Stantec Consulting Ltd. (Stantec) to prepare a preliminary dewatering plan in support of the proposed grade separation construction. The purpose of this preliminary dewatering plan is to establish the general means and methods of groundwater control and disposal to be undertaken during construction. Further details will be provided within the dewatering plan prepared by the General Contractor, prior to the start of construction.

This preliminary dewatering plan is based on the technical reporting included within the following engineering reports and design plans:

1. AECOM. 2019a. Geotechnical and Hydrogeological Data Report, CN Milton Logistics Hub, Milton, Ontario. August 2019.
2. AECOM. 2019b. Memo Re: Milton Logistics Hub, Lower Baseline Grade Separation, Roads Design – Evaluation of Construction Limits. November 19, 2019.
3. Stantec Consulting Limited. 2015. Milton Logistics Hub - Technical Data Report, Hydrogeology (Appendix E.6 of Milton Logistics Hub, Environmental Impact Statement). December 7, 2015.
4. Stantec Consulting Limited. Letter Re: Milton Logistics Hub Lower Base Line Grade Separation Construction Dewatering Assessment. June 24, 2020.

## **PROPOSED CONSTRUCTION**

To avoid disruption to vehicular traffic while trains enter or exit the Terminal, a grade separation is proposed where Lower Base Line crosses the existing mainline, just east of Tremaine Road (Figure 1, Attachment A). The proposed grade separation will route Lower Base Line beneath the existing tracks and will maintain existing traffic flow along Lower Base Line in a safe and efficient manner. As per AECOM (2019b), the grade separation will consist of an underpass that maintains a 2-lane roadway arrangement that will have no sidewalks or paths and a straight horizontal alignment. The roadway alignment will give access to several existing residential properties and include an at-grade crossing with the CN Railway Corridor, which is located approximately 385 meters (m) east of Tremaine Road. Based on the preliminary design drawings (AECOM, 2019b), the alignment footprint will extend a linear distance

**Reference:** Preliminary Dewatering Plan for Milton Logistics Hub Lower Base Line Grade Separation Construction, Milton, ON

of approximately 300 m, with existing grades being excavated up to 4.7 m below ground surface (BGS) (173.9 m above mean sea level (AMSL)) at its deepest point.

## **LOCAL HYDROGEOLOGY AND DEWATERING ASSESSMENT**

Characterization of local hydrogeological conditions and an assessment of the dewatering rate is provided within Stantec's (2020) Construction Dewatering Assessment Report. A summary of hydrogeological conditions along the proposed grade separation is shown on Figure 2 (Attachment A). Overburden soils reflect a massive deposit of clayey silt associated with the Peel Plain Sediments and Halton Till. These clayey silt soils are approximately 20 m thick, encountered from near ground surface (approximately 179 m AMSL) to the bedrock surface (approximately 159 m AMSL). The horizontal hydraulic conductivity of the clayey silt soils are reported to be on the orders of  $10^{-7}$  to  $10^{-10}$  m/s (Stantec 2015). Underlying the overburden soils are the red, Ordovician aged shales of the Queenston Formation.

Key conclusions and recommendations of the dewatering assessment (Stantec, 2020) are as follows:

- Along the proposed grade separation, the water table depth generally ranges from 1.7 to 3.9 m BGS.
- The proposed grade separation corridor will represent a total length of 300 m and width of 16 m.
- The lowest elevation of the proposed grade separation is approximately 174.5 m AMSL (4.7 m BGS). To facilitate construction of the road base and sub-grade drainage system, the maximum depth of the temporary excavation is expected to be 173 m AMSL (6.2 m BGS).
- To maintain well-drained conditions within the excavation, a steady state groundwater pumping of 30 m<sup>3</sup>/day (30,000 L/day) has been estimated.
- Higher pumping rates can be expected following precipitation events and at the start of dewatering operations (i.e., in order to remove existing groundwater storage within the overburden). Peak dewatering rates of 250 m<sup>3</sup>/day (250,000 L/day) are therefore anticipated for short periods of time, following wet weather flow conditions.
- The dewatering zone of influence (ZOI) is not expected to extend beyond a lateral distance of 14 m from the edge of the grade separation. As such, the operation of private water supply wells should not be affected during the proposed construction.

If the Project is subject to provincial requirements, an Environmental Activity and Sector Registry (EASR) can facilitate the permitting requirements for groundwater pumping.

## RECOMMENDED GROUNDWATER CONTROL MEASURES

Excavations will extend into dense, cohesive fined-grained soils. Due to the low hydraulic conductivity of these soils (less than  $10^{-7}$  m/s), groundwater inflow will reflect minor seepage along the sidewalls and from the base of excavation. As such, Stantec recommends that groundwater be controlled using filtered sumps within the excavation areas. These sumps could reflect 300 mm diameter rigid pipe that is perforated or slotted. As shown in Photo 1 below, the pipe should be driven or dug up to 1 m below the base of excavation. The perforated / slotted pipe should be lined with terrafix® filter fabric and surrounded with clear stone at surface.



**Photo 1: Example of pumping from filtered sumps within excavation areas**

A preliminary layout of the proposed dewatering system is shown on Figure 1. Stantec recommends that one or two filtered sumps be installed on each side of the grade separation, with the dewatering system including the following components:

- Two submersible pumps (GSP20 or equivalent); a primary and a back-up. The specifications of these submersible pumps are attached within Appendix B.
- A float system and control panel set-up for each pump, to control on / off operation.
- Primary and back-up power systems to provide continuous power to the pumps.
- A weir tank or filter bag (or equivalent) be used to allow for sedimentation of suspended solids within the pumped groundwater, prior to discharge to Tributary C.

Reference: Preliminary Dewatering Plan for Milton Logistics Hub Lower Base Line Grade Separation Construction, Milton, ON

## **DISPOSAL OF PUMPED GROUNDWATER**

Following sedimentation of suspended solids within a weir tank or filter bag, dewatering effluent should be diverted to Tributary C along the southeast side of Lower Base Line (Figure 1, Attachment A). At the discharge point, an energy dissipation and erosion control measure must be established. These measures could reflect a combination of filter fabric and hay bales, which are designed to limit the potential for erosion and /or scouring within Tributary C. If necessary, a treatment and filtration system can be installed on the downstream end of the weir tank to treat the dewatering effluence as needed to comply with provincial water quality objectives (PWQO).

## **RECOMMENDED MONITORING**

During construction dewatering, Stantec recommends that the pumping rate be monitored and recorded based on pump size/rating curves, field measurements of flow rate be taken when possible, and duration of pumping be recorded each day by the Contractor. Ideally, a digital flowmeter should be installed on the outflow of the weir tank to monitor the instantaneous and cumulative rate of dewatering effluent discharge.

When discharging to the adjacent area, Stantec recommends that the Contractor complete the following additional mitigation measures and monitoring:

- The geotextile filter bag or equivalent shall be checked daily and replaced as needed.
- The discharge location shall be inspected daily to verify that no significant erosion or sedimentation is occurring.
- Visual and olfactory inspections of the discharge location shall be completed daily. The water being discharged shall not contain any oil or any other substances in amounts to create a visible film, sheen, foam or discolouration in the discharge water.

Following the start-up of the dewatering system, Stantec recommends that a sample of the dewatering effluent be collected and analyzed for compliance with PWQO.

## **CLOSURE AND LIMITATIONS**

Stantec trusts that this preliminary dewatering plan is suitable for your planning purposes in support of the proposed grade separation construction along the Lower Base Line, within the PDA of the Milton Logistics Hub in the Town of Milton. Should you have any questions, or require further information, please do not hesitate to contact the undersigned.

March 1, 2021

Luanne Patterson, Sr. System Manager – EA Environment

Page 5 of 5

**Reference: Preliminary Dewatering Plan for Milton Logistics Hub Lower Base Line Grade Separation Construction, Milton, ON**

This Preliminary Dewatering Plan was prepared by Stantec Consulting Ltd. (“Stantec”) for the account of Canadian National Railway Company (the “Client”). Any reliance on this document by any third party is strictly prohibited. The material in it reflects Stantec’s professional judgment in light of the scope, schedule and other limitations stated in the document and in the contract between Stantec and the Client. The opinions in the document are based on conditions and information existing at the time the document was published and do not take into account any subsequent changes. In preparing the document, Stantec did not verify information supplied to it by others. Any use which a third party makes of this document is the responsibility of such third party. Such third party agrees that Stantec shall not be responsible for costs or damages of any kind, if any, suffered by it or any other third party as a result of decisions made or actions taken based on this document.

Sincerely,

**Stantec Consulting Ltd.**

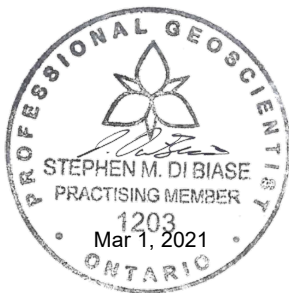

**Stephen Di Biase** P.Geo.  
Senior Hydrogeologist  
Office: (905) 415-6330  
Mobile: (647) 282-0563  
Stephen.DiBiase@stantec.com

<Original signed by>

**Grant Whitehead** MES, P.Geo. (Limited)  
Senior Hydrogeologist  
Office: (519) 585-7400  
Mobile: (519) 502-8933  
grant.whitehead@stantec.com

Attachments: Attachment A:  
Figure 1 – Preliminary Groundwater Control Plan  
Figure 2 – Cross-Section LB-LB'  
Attachment B:  
Specification for Submersible Pumps  
Specification for Sedimentation Tank

c. France Moreau, CN  
Chris Powell, Stantec Consulting Limited  
Grant Whitehead, Stantec Consulting Limited

ct m:\01609\active\160960844\planning\reports & deliverables\hydrogeology\lbl\_dewatering\preliminary dewatering plan\final\tr\_20210301\_cn.milton.logistics.hub\_dwp\_160960844\_final.docx

# **Attachment A**

## **Figures**

\\cd1220-02\Work\_group\01609\active\60960844\drawing\AMD\Hydrogeology\Report\_Figures\DeWatering\_LowerBaseline\60960844\_HG\_deWater\_Fig01\_PrelimGridControl.mxd  
 Revised: 2020-05-14 By: ccoghlan

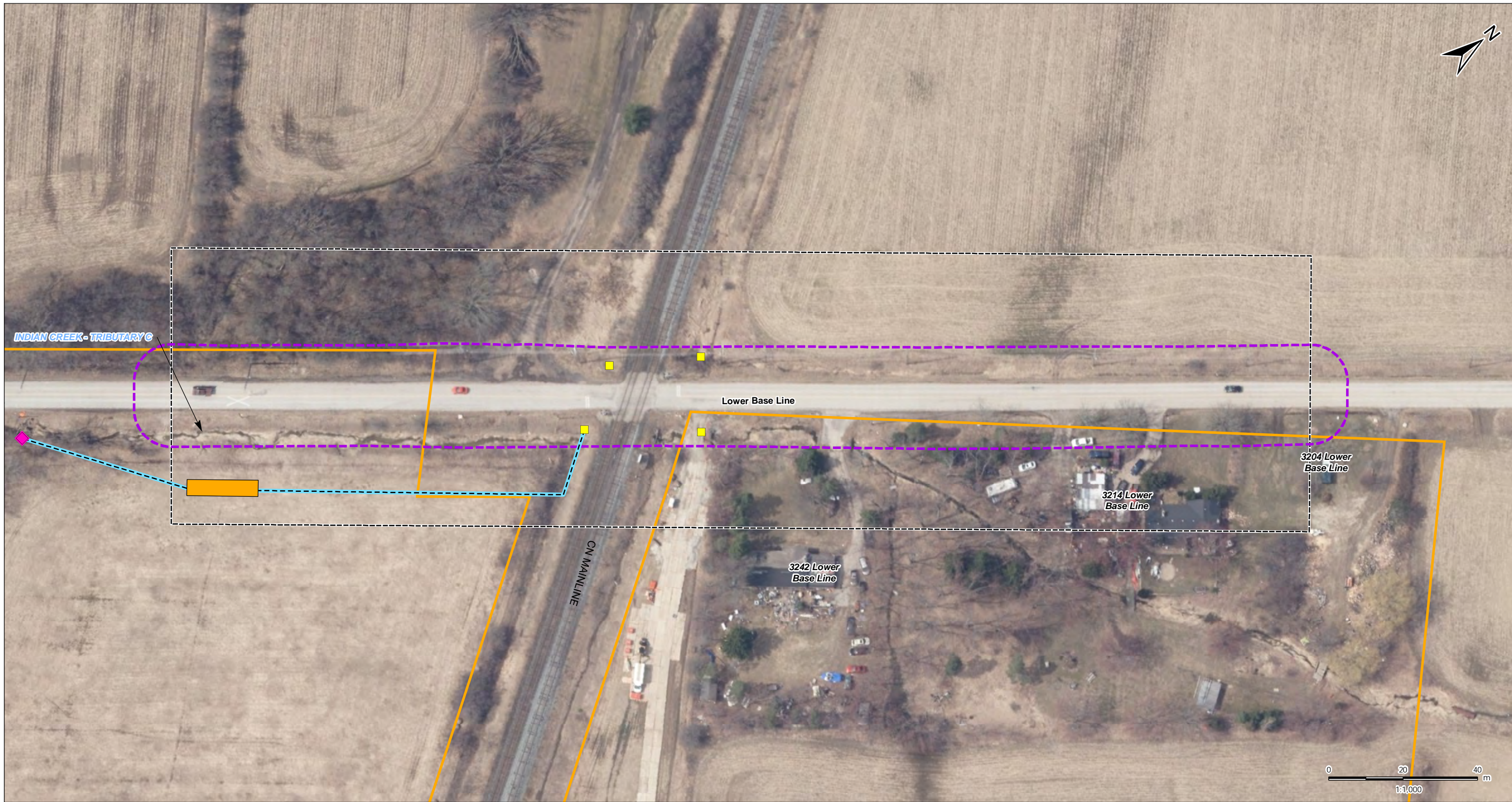

- Legend**
- Project Components**
- Project Development Area
  - Lower Base Line Grade Separation Area
  - Estimated Dewatering Zone of Influence
  - Possible Location for Discharge of Dewatering Effluent
  - Possible Location for Filtered Sumps
  - Dewatering Effluent Diversion Manifold
  - Settlement Tank

- Notes**
1. Coordinate System: NAD 1983 UTM Zone 17N
  2. Base features produced under license with the Ontario Ministry of Natural Resources and Forestry © Queen's Printer for Ontario, 2019. Site layout: July 10, 2015.
  3. Orthoimagery © First Base Solutions, 2019. Imagery taken in 2019.
  4. MOECC water well locations are approximate and have been positioned based on published UTM coordinates.

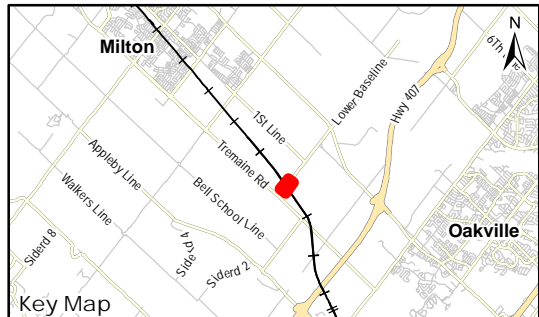

Client/Project  
 Canadian National Railway  
 Milton Logistics Hub  
 Preliminary Dewatering Plan

Figure No.  
 1

Title  
 Preliminary Groundwater  
 Control Plan





**Attachment B**  
**Specifications**

# GSP05/10/20 Sub-Prime® Electric Submersible Pumps

The GSP Sub-Prime line is a selection of portable, electric submersible dewatering pumps available for a wide range of pumping applications on construction, industrial, mining, utility, and municipal job sites. Available in 0.5 hp / 0.4 kW (GSP05), 1 hp / 0.75 kW (GSP10), and 2 hp / 1.5 kW (GSP20) models, the GSP Sub-Prime offers flow rates from 70 through 110 gpm (4.4 through 6.9 l/sec) and maximum heads from 39 to 70 feet (11.9 to 21.3 meters). Compact design allows these versatile units to go where other pumps simply would not fit. An optional piggy back single float switch can be supplied as a cost-effective choice for applications requiring automatic operation.

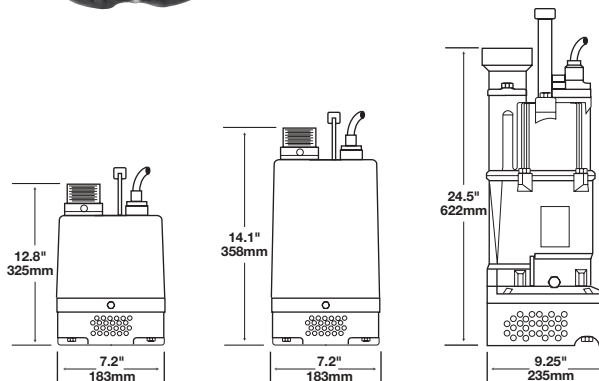

## Features

- UL listed & approved \*
- Dry running capability without damage
- No control panel required for starting. (Control panel is required for motor protection.)
- Portable, lightweight, durable
- Slim line top discharge design, only 7.2" (183mm) diameter for 0.5 and 1 hp (0.4 and 0.75 kW) models, 9.25" (235mm) diameter for 2 hp (1.5 kW) model
- Non-wicking cable with strain relief
- High-torque, capacitor-start motor
- Motor thermal overload protection
- Outer jacket for continuous cooling of motor
- Silicon Carbide upper and lower mechanical seals
- Triple seals — internal upper & lower mechanical seals and external lip seal
- Torque flow impeller

## Specifications

	GSP05	GSP10	GSP20†
HP/kW	0.5 HP/0.4 kW	1.0 HP/.75 kW	2.0 HP/1.5 kW
Max. Flow	70 gpm (4.4 l/sec)	90 gpm (5.7 l/sec)	110 gpm (6.9 l/sec)
Max. Head	39' (11.9M)	60' (18.3M)	70' (21.3M)
Max. Solids	1/3" (9mm)	1/3" (9mm)	1/3" (9mm)
Cable Length	30' (9M)	50' (15M)	50' (15M)
Discharge Size	2" (50mm)	2" (50mm)	3" (75mm)
RPM	3600	3600	3600
Max. Fluid Temp.	90° F (32° C)	90° F (32° C)	104° F (40° C)
PH Range	6.5-8.0	6.5-8.0	6.5-8.0
Voltage	115, 230	115, 230	115/230
Amps	5.8, 3.2	10.3, 5.11	25.9/13.0
Phase	Single	Single	Single
Height	12.8" (325mm)	14.1" (358mm)	24.5" (622mm)
Width	7.2" (183mm)	7.2" (183mm)	9.25" (235mm)
Weight	20 lbs. (9 kg.)	29 lbs. (13 kg.)	61 lbs. (28 kg.)
Max. Sub.	16.5' (5M)	16.5' (5M)	16.5' (5M)

\* n.a. for GSP20

†GSP20 CSA certification pending.



# GSP Sub-Prime® Performance Curves

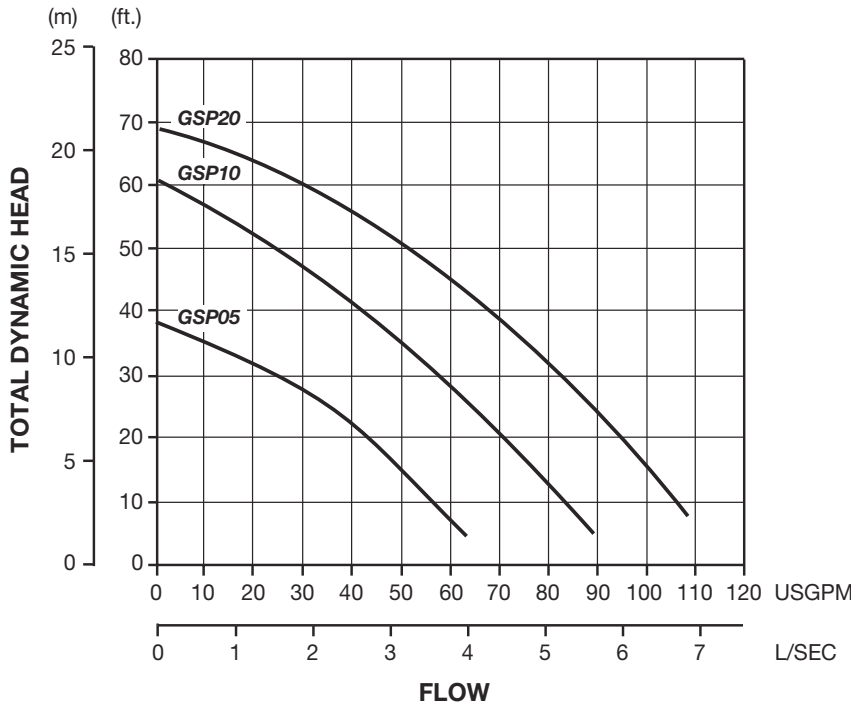

**WARNING:** Pumps are not designed for use in explosive atmosphere, flammable environments or for pumping volatile liquids.

## Design & Construction

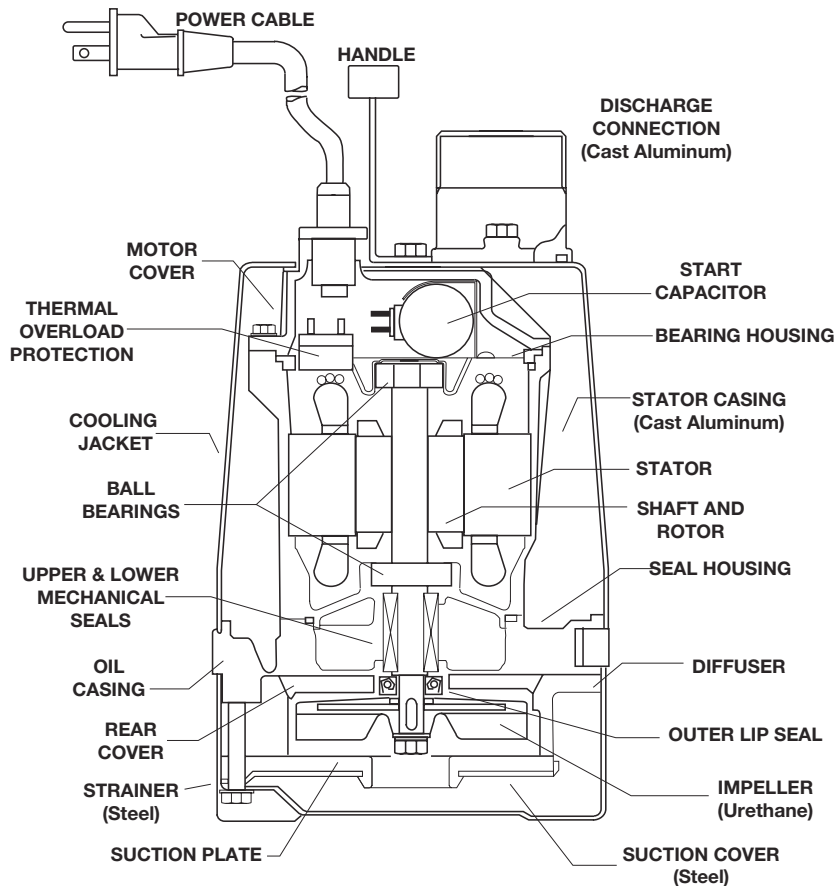

## Float Switch

Optional Float Switches available for automatic, remote activation of Sub-Prime pumps. Package consists of 30'/50' (9M/15M) power cord with piggy-back power plug, variable length float tether, and sealed float. Typical configuration shown in the following.

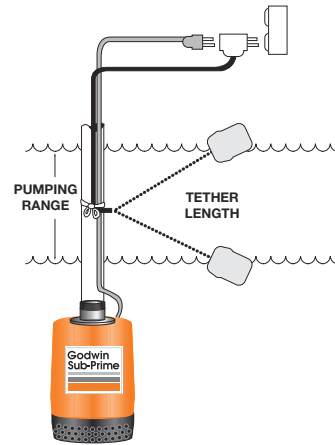

Pumping range determined by tether length according to the following guide.

Tether Length	3.5	5	7	9	11	13	15	(in.)
	89	127	178	229	279	330	381	(mm)
Pumping Range	6.5	7.5	8.5	10	11	12.5	13.5	(in.)
	165	191	216	254	279	318	343	(mm)

Pumping range based on operation in non-turbulent conditions. Actual range may vary due to temperature conditions and cord shape. Tether length increases variance of pumping range.



†GSP20 CSA certification pending.



69 Connie Crescent, Concord, ON L4K 1L3  
PHONE: 905.907.1700 FAX: 905.907.1701  
www.aquatechdewatering.com



One Floodgate Road, Bridgeport, NJ 08014, USA  
(856) 467-3636 • Fax: (856) 467-4841  
Quenington, Cirencester, Glos., GL7 5BX, UK  
+44 (0)1285 750271 • Fax: +44 (0)1285 750352

E-mail: sales@godwinpumps.com  
www.godwinpumps.com

### BRANCH LOCATIONS:

Connecticut • Pennsylvania • New York • Ohio  
Illinois • Maryland • Virginia • West Virginia  
Georgia • South Carolina • North Carolina  
Florida • Texas • Montana • California • Washington

Sub-Prime® and the color orange for pumps are registered trademarks of Godwin Pumps of America, Inc. Specifications and illustrations are subject to revision without notice. © Copyright 2002-2006 Godwin Pumps of America, Inc.

# 18,000-Gallon Weir Tank



Open-Top Weir / Mobile Storage Tank

## Specifications

<b>Dimensions</b>	45 ft. (13.72 m) long x 8 ft. 6 in. (2.59 m) wide x 11ft. (3.35 m) high
<b>Weight</b>	26,000 lb. (11793.40 kg)
<b>Capacity</b>	18,000 gal. (68137.41 l) (nominal)
<b>Valves</b>	Two 4 in. (10.16 cm) butterfly valve drains with NPT threads, one at each end in recessed sumps
<b>Fill/Overflow Line</b>	Top 3 in. (7.62 cm) feed line with cap and NPT threads
<b>Manways</b>	Three manways for access to each compartment All manways equipped with butterfly-style nuts

Specifications are approximate and may vary. Ask your sales representative for specific dimensions for the unit we supply to you.

## Options & Accessories

- Steam Coils
- Suction and Discharge Hoses
- Level Gauges
- Secondary Containment Berm

