



SEARCH
MINERALS

CEAA Project Description

Foxtrot Rare Earth Element Mine

Submitted By: Search Minerals Inc.
#211, 901 West 3rd Street, North Vancouver, BC V7P 3P9

Prepared By: Allnorth
2 Hunt's Lane, St. John's, NL A1B 2L3
Phone: 709-579-1492

Project Number: 15SJ0072

Date: 27 November 2017



DOCUMENT INFORMATION

Project Number:	15SJ0072
File Number:	
Filename:	171127_15SJ0072_CEAA Project Description Final
Document Revision:	1

REVISION HISTORY

Rev.#	Date of Issue	Reviewed By	Approved By	Description
0	10 Feb 2017	AM		Initial release
1	9 June 2017	AM		Second Agency Draft Review
2	28 July 2017	AM		Formal CEAA Submission
3	20 November 2017	AM		Revised Submission
4	27 November 2017	AM		Revised Submission



TABLE OF CONTENTS

1	INTRODUCTION	1
1.1	Name of the Project	1
1.2	Proponent.....	1
1.3	Name and Address of Proponent	1
1.4	Project Description Contact.....	2
1.5	Project Regulatory Framework	2
1.5.1	CEAA – Regulations Designating Physical Activities	2
1.5.2	List of Permits, Licenses and Other Authorizations	2
1.6	Overview of Consultation and Engagement	4
1.7	Subject to Other Jurisdictions.....	5
1.8	Regional Environmental Studies	5
1.9	Federal Funding and Lands	5
2	PROJECT INFORMATION.....	6
2.1	Proposed Project	6
2.2	Overview of the Undertaking.....	6
2.3	Purpose, Rationale, and Need for the Undertaking	7
3	DESCRIPTION OF THE UNDERTAKING.....	12
3.1	Geographic Location	12
3.2	Physical Features.....	12
3.3	Construction Activities.....	12
3.3.1	General	12
3.3.2	Process Facility.....	13
3.3.3	Laboratory	23
3.3.4	Utilities and Services.....	23
3.3.5	Mobile Equipment.....	24
3.3.6	Administration Building	24
3.3.7	Maintenance Building	24
3.3.8	Accommodations	24



3.3.9	Port Facilities	25
3.4	Mining Operations	26
3.4.1	Open Pit Mining	26
3.4.2	Underground Mining	27
3.4.3	Waste Dump and Low- Grade Stockpile	29
3.5	Waste, Emissions, and Discharges	29
3.6	Reclamation	31
4	ENVIRONMENTAL SETTING	32
4.1	Physical Environment	32
4.1.1	Physical Environment	32
4.1.2	Climate	32
4.1.3	Surficial Geology	33
4.1.4	Bedrock Geology	34
4.1.5	Hydrology	34
4.1.6	Hydrogeology	35
4.1.7	Air Quality and Noise	35
4.2	Biological/Ecological Environment	37
4.2.1	Vegetation	37
4.2.2	Mammals	38
4.2.3	Amphibians and Reptiles	38
4.2.4	Birds	38
4.2.5	Fish and Fish Habitat	39
4.2.6	Species at Risk (SAR)	39
4.3	Socio-Economic Setting	40
4.3.1	Demography	40
4.3.2	Employment and Economy	41
4.3.3	Transportation	42
4.3.4	Other Infrastructure and Services	42
4.3.5	Recreation and Tourism	43
4.3.6	Land Use	44



5 ENVIRONMENTAL EFFECTS.....	47
5.1 Effects on Fish and Fish Habitat.....	47
5.2 Effects on Marine Plants	47
5.3 Effects on Migratory Birds.....	47
5.4 Effects on Federal Lands	48
5.5 Potential Effects on Aboriginal Peoples.....	48
6 ENGAGEMENT AND CONSULTATION.....	49
6.1 Aboriginal and Community Engagement.....	49
6.2 Government Consultation.....	50
7 SCHEDULE	51
7.1.1 Capital Costs.....	53
8 FUNDING.....	53
9 REFERENCES.....	54

APPENDICES

Appendix A List of Potential Sara Species

LIST OF TABLES

Table 1 Government of Canada Permits.....	3
Table 2 Government of Newfoundland and Labrador and Municipal Permits and Authorizations.....	3
Table 3 Anticipated Difference in Processes	21
Table 4 Major Project Consumables and Estimated Annual Usage.....	22
Table 5 Climate Data Summary 1981-2010	32
Table 6 Greenhouse gas emissions anticipated from the Project compared to Provincial, Canada and Global Targets.	33
Table 7 Summary of Proponent Engagement with the NunatuKavut.....	49
Table 8 Summary of Proponent Engagement with the Local Communities.....	49
Table 9 Production Schedule.....	51
Table 10 Capital Cost Summary	53



LIST OF FIGURES

Figure 1 Project Location Map.....	9
Figure 2 General District Location	10
Figure 3 Potential Prospects/Targets	11
Figure 4 Overall Foxtrot Infrastructure Layout.....	14
Figure 5 Mine and Mill Infrastructure Layout.....	15
Figure 6 Conceptual Ore Processing Block Flow Diagram	18
Figure 7 Conceptual Processing Facility Layout	19
Figure 8 Open Pit Design Cross Section.....	28
Figure 9 Waterbodies and Watercourses in the Project Area.....	36
Figure 10 Cumulative Aboriginal Land Uses in the Project Area	46
Figure 11 Foxtrot Mine Development Timeline.....	52



List of Acronyms and Abbreviations

Abbreviation	Term	Abbreviation	Term
a	annum	LREO	light rare earth oxides
A	ampere	L/s	litres per second
ACOA	Atlantic Canada Opportunities Agencies	m	metre
Agency	Canadian Environmental Assessment Agency	M	mega(million);molar
ANFO	Ammonium-nitrate Fuel Oil	m ²	square metre
bbbl	barrel	m ³	cubic metre
btu	British Thermal Units	μ	micron
°C	degree Celsius	MASL	metres above sea level
C\$	Canadian dollars	μg	microgram
cal	calorie	m ³ /a	Cubic metres per annum
cfm	cubic feet per minute	m ³ /h	cubic metres per hour
CEAA 2012	Canadian Environmental Assessment Act 2012	MgCO ₃	Magnesium Carbonate
cm	centimetre	mi	mile
cm ²	square centimetre	min	minute
COSEWIC	Committee on the Status of Endangered Wildlife in Canada	μm	micrometre
Crf	Cement filled rock	mm	millimetre
d	day	mph	miles per hour
dia	diameter	mt	Metric tonnes
dmt	dry metric tonne	Mt	Mega tonnes
dwt	dead-weight tonne	MVA	megavolt-amperes
EA	Environmental Assessment	MW	megawatt
EPCM	Engineering Procurement And Construction Management	MWh	megawatt-hour
°F	degree Fahrenheit	NaCO ₃	Sodium Carbonate
ft	foot	NCC	NunatuKavut Community Council
ft ²	square foot	NCR	Net Smelter Return
ft ³	cubic foot	oz	Troy ounce (31.5g)
Ft/s	foot per second	Oz/st, opt	ounce per short ton
g	gram	PEA	Preliminary Economic Assessment
G	Giga(billion)	ppb	part per billion
Gal	Imperial gallon	ppm	part per million
g/L	gram per litre	psia	pound per square inch absolute
Gpm	Imperial gallons per minute	psig	pound per square inch gauge
g/t	Gram per tonne	RDC	Research and Development Corporation of NFLD
gr	grain	REE	rare earth element
Gr/ft ³	grain per cubic foot	REO	rare earth oxide
Gr/m ³	grain per cubic meter	RL	relative elevation
ha	hectare	RPA	Roscoe Postle Associates
HCl	Hydrogen Chloride	ROM	run-of-mine
hp	horsepower	RSF	residue storage facility
hr	hour	s	second
HREE	heavy rare earth elements	st	short ton
HREO	heavy rare earth oxides	stpa	short ton per year
Hz	hertz	stpd	short ton per day
in	inch	t	metric tonne



Abbreviation	Term	Abbreviation	Term
in ²	square inch	tpa	metric tonne per year
J	joule	tpd	metric tonne per day
k	Kilo(thousand)	TREE	total rare earth elements
kcal	kilocalorie	TREO	total rare earth oxides
kg	kilogram	US\$	United States dollar
km	kilometre	USg	United States gallon
Km/h	kilometer per hour	USgpm	United States gallon per minute
kPa	kilopascal	V	volt
kVA	Kilovolt-amperes	W	watt
kW	kilowatt	wmt	wet metric tonne
kWh	Kilowatt-hour	wt%	weight percent
L	litre	Yd ³	cubic yard
lb	pound	yr	year
Lp	Low pressure		
LOM	Life of mine		
LMN	Labrador Metis Nation		
LREE	light rare earth elements		



1 INTRODUCTION

1.1 Name of the Project

The name of the Project is the **Foxtrot** Rare Earth Element Mine Development.

1.2 Proponent

Search Minerals Inc. (Search) was incorporated on June 7, 2006 under the Business Corporations Act of British Columbia and the Company is trading on the TSX Venture Exchange under the symbol "SMY.V."

Search is focused on creating value through finding and developing "critical rare earth element ("CREE")" mineral assets in Labrador. CREEs (Neodymium (Nd), Praseodymium (Pr), Europium (Eu), Terbium (Tb), Dysprosium (Dy), Yttrium (Y)) and strategic metals have growing demand, constrained or restricted supply and are commonly used in innovative technologies.

Search is the discoverer of the Port Hope Simpson CREE District, a highly prospective CREE belt located in southeast Labrador, where the Company controls a belt 70 km long and up to 8 km wide. Search owns 100% of the advanced CREE resource called the **Foxtrot** Project ("**Foxtrot**"). In addition, the Company has identified more than 20 other **Foxtrot**-like prospects in the District.

The primary focus of Search is to continue to advance the **Foxtrot** resource, while evaluating other **Foxtrot**-like prospects. Several of the **Foxtrot**-like prospects require exploration drilling programs and may provide additional resources to a central processing facility that would be situated within the District.

In addition, Search holds a number of other CREE mineral prospects in Labrador in its portfolio, including claims in the Red Wine Complex and in the Henley Harbour area.

1.3 Name and Address of Proponent

Search Minerals Inc.

Address (Head Office): #211, 901 West 3rd Street
North Vancouver, British Columbia
V7P 3P9

Chief Executive Officer

Name: Greg Andrews
Title: President and CEO
Telephone Number: (604) 602-1175
Email: gregandrews@searchminerals.ca

1.4 Project Description Contact

The Project Description prepared by Allnorth Consultants Limited (Allnorth) on Search Minerals' behalf.

Allnorth Consultants Limited

Name: Andrew McIntosh, P.Eng.
Address: 102-100 Venture Run
Dartmouth, Nova Scotia B3B 0H9
Telephone Number: (902) 835-9758
Email: amcintosh@allnorth.com

1.5 Project Regulatory Framework

The Project will require a review for consideration for under both the federal and provincial regulations. The following section presents the anticipated environmental regulatory framework for the Project.

1.5.1 CEAA – Regulations Designating Physical Activities

Under the *Canadian Environmental Assessment Act 2012 (CEAA 2012)*, an environmental assessment (EA) may be required for designated projects. Designated Projects are listed in the Schedule of the *Regulations Designating Physical Activities (CEAA 2012)*. A Project Description is to be submitted to the Canadian Environmental Assessment Agency (the Agency) to determine whether an environmental assessment of the designated project is required.

Paragraph 16(c) of the regulations identifies the following activity as a designated project;

“The construction, operation, decommissioning and abandonment of a new – rare earth element mine or gold mine, other than a placer mine, with an ore production capacity of 600 t/day or more;...”

The proposed **Foxtrot** REE mine is anticipated to have an ore production capacity of 1000 t/day, therefore it is a designated project under *CEAA 2012*. Therefore, a Project Description has been prepared and submitted to the Agency for determination as to whether the Project required a federal EA.

1.5.2 List of Permits, Licenses and Other Authorizations

It is understood that, by regulation, the Project will be subject to both federal and provincial environmental assessment (EA) processes. This document is prepared to satisfy the requirements of the *CEAA 2012* Project Description. A separate document has been prepared to satisfy the provincial process.

The anticipated federal, provincial and municipal permits are listed in Tables 1 and 2 below.



Table 1 Government of Canada Permits

Government Department	Permit/Authorization
Canadian Environmental Assessment Agency	Decision Statement
Environment and Climate Change Canada	Environmental Compliance
	Metal Mining Effluent Regulations
	Wetlands Authorization
	Migratory Birds
Fisheries and Oceans Canada	Request for Project Review
	Letter of Advice or Authorization for Works or Undertakings affecting Fish Habitat
Transport Canada	Transportation of Dangerous Goods
	Permit for construction of structures in or near navigable waters
	Approval of Emergency Response Plans
Natural Resources Canada	Permit to transport explosives
	License for explosives magazine
Industry Canada	Radio Station license

Table 2 Government of Newfoundland and Labrador and Municipal Permits and Authorizations

Government Department	Permit/Authorization
Municipal Affairs and Environment	Decision Statement (Release from EA)
	Water Use License
	Permit to construct waterworks
	Certificate of Approval
	Approval for waste disposal (landfill)
	Permit to construct sewage works
	Certificate of Registration
	Permit to occupy Crown Land
	Fording
	Culvert Installation
	Certificate of Approval for construction and operation
	Certificate of Approval for generators
	Approval of MMER Emergency Response Plan
	Approval of Environmental Response Plan (spills)
	Approval of Environmental Protection Plan
	Permit to control Nuisance Animals
	Certificate of Approval for alteration of a Body of water
Certificate of Approval for site drainage	



Government Department	Permit/Authorization
	Water use license
	Permit for constructing a non-domestic well
Natural Resources (Mining)	Surface lease
	Quarry permit (if required)
	Surface rights lease
	Mine Development Plan
	Mine Closure Plan including Financial Security
Natural Resources (Forestry)	Permit to burn
	Operating permit to carry out an industrial Operation during forest fire season on Crown land
	Permit to cut crown timber
Services NL	Fuel tank registration-storage and handling Gasoline and associated products
	Mobile Fuel Storage Tank Relocation
	Permit for storage, handling and use of Flammable and Combustible Liquids
	Certificate of Approval for Collecting and Transporting Used Oil
	Explosives permit
	Blaster's Safety Certificate
	Temporary fuel cache
	National Building Code - Fire, Life Safety and Building Safety
Transportation and Works	Upgrade public highway
	Erect signs on a public highway
	Install an intersection to a public highway
Town of St. Lewis	Development Permit

1.6 Overview of Consultation and Engagement

Search Minerals is committed to ongoing consultation with all stakeholders for the successful development of the **Foxtrot** project. Maintaining constant updates on the progress of activities is primary to the relationships that Search has developed with the local communities, the NunatuKavut and government agencies, both provincial and federal. The following is a list of the regulators and potential stakeholders that were contacted throughout the development of the Project to date.

Federal Government

- Canadian Environmental Assessment Agency

Provincial Government

- Government of Newfoundland and Labrador - Natural Resources
- Government of Newfoundland and Labrador – Municipal Affairs and Environment
- Government of Newfoundland and Labrador – Labrador and Aboriginal Affairs

Municipal Government

- Community of St. Lewis
- Community of Port Hope Simpson

First Nations

- NunatuKavut

1.7 Subject to Other Jurisdictions

The **Foxtrot REE** project is subject to a review by the government of Newfoundland and Labrador pursuant to the *Environmental Protection Act* (Part X) and the Environmental Assessment Regulations. A Project Registration document will be submitted to the NL Department of Municipal Affairs and Environment in parallel to the CEAA Project Description.

1.8 Regional Environmental Studies

There have been numerous environmental assessment studies in western and northern Labrador for other projects. However, there have not been any in the immediate area of the Search Project.

There are no relevant regional studies of environmental effects from other projects that have been identified.

1.9 Federal Funding and Lands

No federal lands will be used in the construction of the Project. All lands associated with the mine and processing facility are owned by Search.

Funding for the Project will be provided by the Proponent. The Project does not involve any Federal funding for its completion. However, the Atlantic Canada Opportunities Agency (ACOA) has provided funding to Search Minerals for the development of innovative technology for the recovery of rare earth elements from the ore. To date, pilot work has been undertaken with the use of the ACOA funds to develop and refine the operation of a full scale process for when the mine has been developed.

2 PROJECT INFORMATION

2.1 Proposed Project

Search Minerals Inc. is proposing to develop the **Foxtrot** Rare Earth Element (REE) Mine. The **Foxtrot** mine as will have an estimated life of fourteen years; the first eight of which will be open pit mining while the last six years will be underground mining. See **Figure 1** for a geographical location of the Project components.

Exploration to date has yielded positive results. Exploration in this area has been ongoing since 1996 with companies such as Devonian Resources Inc. and Greenshields Resources preceding Search's activities; Search has been in the area since 2009. Potential prospects/targets identified to date are shown on **Figure 3**. However, the primary focus currently is on the development of the **Foxtrot** project.

This document has been prepared in accordance with the Government of Canada's *Prescribed Information for the Description of Designated Project Regulations* (Government of Canada 2012). The purpose of this report is to provide a general description of the Project and its components.

2.2 Overview of the Undertaking

The project will be developed using conventional construction techniques. The **Foxtrot** deposit is the most advanced and its key features are as follows:

- The life of the mine is anticipated to be 14 years
- For the first 8 years mining will be by open pit method and for the last 6 years it will be an underground operation
- During the open pit operations mining will only be for 6 months of the year (May to October) and the mining rate will be 2000 tonnes per day. The ore will be stored at the mill site which will operate 12 months of the year.
- During the underground phase of the project mining will take place 12 months of the year and will be at the rate of 1000 tonnes per day
- A processing mill with a feed rate of 1000 tonnes per day on an annual basis. It is estimated that 10 tonnes of finished product will be produced per year at the milling rate of 1000 tonnes per day
- The product will be shipped out by truck over the Tran Labrador Highway to Montreal for furtherance by surface means if the final destination is North America. If the product's final destination is Europe or China, in all likelihood it will be transported by surface means, on the Trans-Labrador Highway, crossing the Strait of Belle Isle from Blanc Sablon to St. Barbe by ferry, and then on to St. Anthony for furtherance by Eimskip using marine transport.
- During operations it is estimated that there will be a requirement for 139 people for the open pit phase and 222 for the underground phase.

2.3 Purpose, Rationale, and Need for the Undertaking

Rare earth elements are a set of seventeen chemical elements in the periodic table, specifically the fifteen lanthanides plus scandium and yttrium. Scandium and yttrium are considered rare earth elements since they tend to occur in the same ore deposits as the lanthanides and exhibit similar chemical properties. While named rare earths, they are in fact not that rare and are relatively abundant in the Earth's crust. What is unusual is to find them in quantities significant enough to support economic mineral development.

Ce - Cerium	La – Lanthanum	Sm – Samarium
Dy - Dysprosium	Lu - Lutetium	Tb – Terbium
Eu – Europium	Nd - Neodymium	Tm – Thulium
Er – Erbium	Pm - Promethium	Y – Yttrium
Gd – Gadolinium	Pr – Praseodymium	Yb - Ytterbium
Ho - Holmium	Sc - Scandium	

Note: Bold elements are Critical Rare Earth Elements (CREE).

With rare earths, a little goes a long way. The amount of rare earths used in high tech equipment is nominal but almost always critical to the unit's performance. For example, an iPhone uses eight rare earths – for everything from its colored screen, to its speakers, to the miniaturization of the phone's circuitry. While the amount of rare earths in each phone is very small, the quantity of phones sold each year is impressive. According to Apple, in 2012 over 125 million iPhones were sold worldwide, up from 72 million in 2011.

Neodymium (Nd), Europium (Eu), Terbium (Tb), Dysprosium (Dy) and Yttrium (Y) are critical rare earths (CREE) for both the short and long term. Rare Element includes Praseodymium (Pr) in this list because of its ability to be substituted for Neodymium in high-intensity permanent magnets. These elements are "critical" because of scarcity. The scarcity of the resource, combined with anticipated growth in demand, makes these higher valued elements the ones we expect to experience price performance over the next decade.

Currently China is the dominant source of all Rare Earth Oxides (REO's), accounting for approximately 97% of world production in 2009. Total latent demand projections for REO outside China range from 46,000 to 52,000 tonnes annually. It is estimated that the **Foxtrot** project alone can produce an average Total Rare Earth Elements (TREE) of approximately 5% of the ROW demand.

According to Asian Metals, the international rare earth market has grown at an unprecedented rate since China cut export quotas by approximately 40% in 2011. China's overwhelming control on the REE supply



chain, from upstream mining to downstream processing and end-user products, is likely to remain intact on all but a few materials through 2016. Further price increases are expected with continued decreases in export availability from major Chinese suppliers and a surge in domestic demand.

A Preliminary Economic Assessment (PEA) prepared by Roscoe Postle Associates Inc. (RPA) for Search Minerals in April, 2016 stated in summary *"The PEA indicates that positive economic benefits can be obtained for the Foxtrot Project and that further advancement of the Project is merited."*



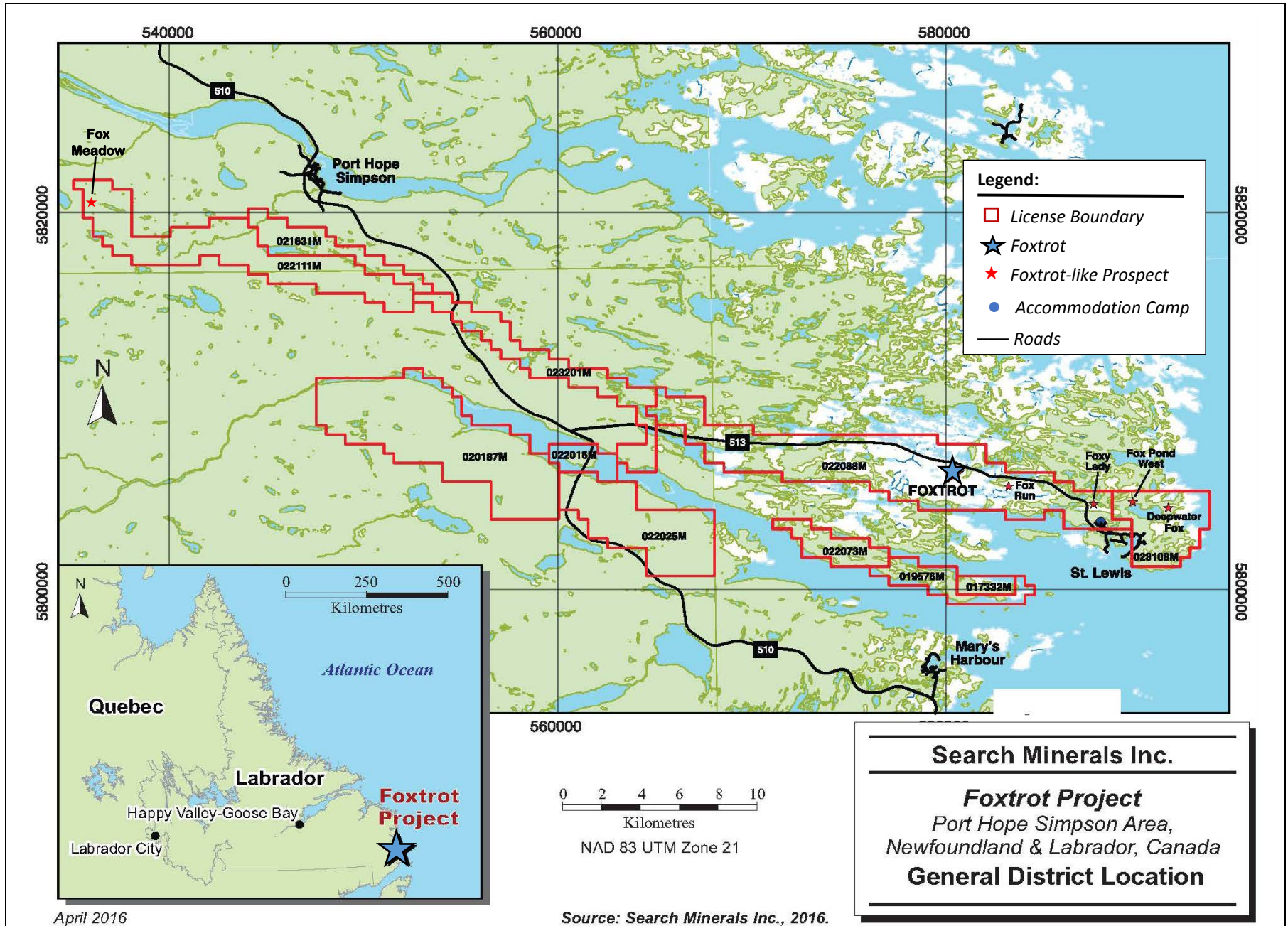

Search Minerals Inc.

Foxtrot Project
 Newfoundland & Labrador, Canada
 Potential Prospects/Targets

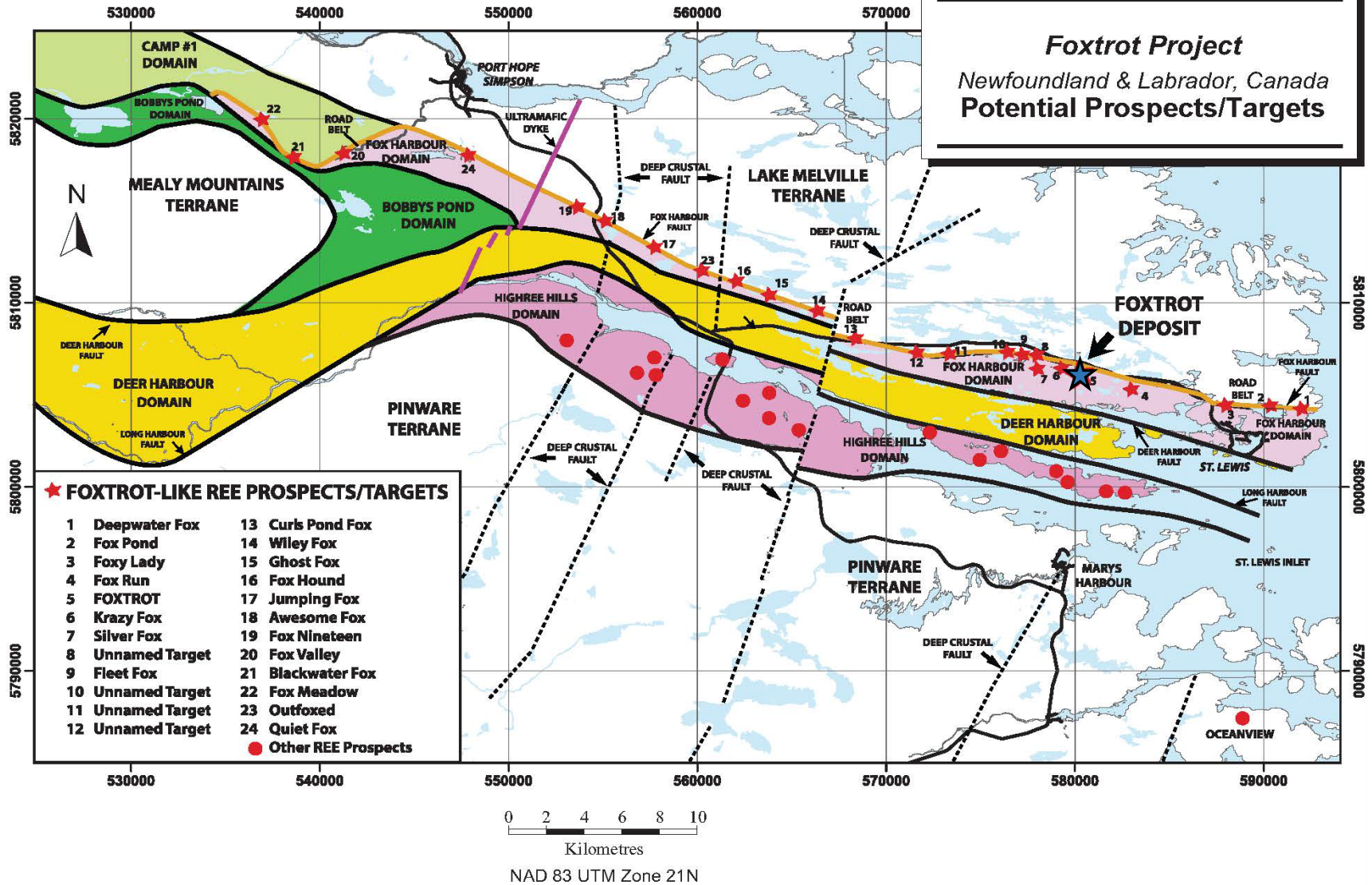

April 2016

Source: Search Minerals Inc., 2016.



Figure 3 – Potential Prospects/Targets



3 DESCRIPTION OF THE UNDERTAKING

3.1 Geographic Location

The Project is located in southern Labrador in the province of Newfoundland and Labrador centred at geographic coordinates 580000E and 5806000N, UTM Grid Zone 21N, NAD83 (**Figure 1**). The various prospects and targets currently under consideration by Search Minerals are shown on **Figure 3** and are in an area known as the Port Hope Simpson Rare Earth Element (REE) District. The **Foxtrot** deposit, the deposit of primary interest, is approximately 36 km east- south east of Port Hope Simpson and approximately 10 km west of St. Lewis. Its location with respect to these communities is shown on **Figures 2** and **3**. The deposit is accessible from the Trans Labrador Highway (Provincial Route 510) along Provincial Route 513 (**Figure 2**).

3.2 Physical Features

The overall preliminary layout for the surface infrastructure for **Foxtrot** Project is shown on **Figure 4**. All features are conceptual at this stage as they may change as feasibility and engineering design advances. **Figure 5** shows the conceptual layout of the mine site with the major features. A general description for each of the main facility components is provided in the following sections.

3.3 Construction Activities

3.3.1 General

Construction of the open pit and the surface infrastructure will take place over an estimated 18-24-month period and could start as early as 2020, with mine production beginning in 2022. Construction of the underground mine would start in 2028 to allow for production in 2030 (Year 8).

The following activities are expected to be carried out during the construction phase:

- Earthworks.
- Civil/Concrete.
- Mechanical and Plate work.
- Structural steel.
- Piping (liquor disposal, acid supply, raw water supply).
- Electrical (transmission line, substation).
- Control and instrumentation.

The work will be undertaken by various contractors and suppliers through tenders issued by Search.

The earthworks will include the grubbing and clearing of vegetation to construct the access road and structures of the mine site. Additional earthworks may include blasting for the provision of granular

material to construct the structures and roads on site. Material may be required to be brought from off-site and will be determined by the contractor awarded the construction work.

Construction of the processing facility, truck shop and administration building will consist of steel frame buildings with concrete foundations.

3.3.2 Process Facility

The process facility consists of sub-areas that includes the following:

- Ore preparation.
- Mixing and Acid Baking.
- Water Leaching, Impurity Removal and REE Precipitation.
- Re-leach and Precipitation.
- Calcination.

The overall conceptual block process and plant layout is shown in **Figure 6**. **Figure 7** shows a conceptual layout of the process facility, chemical storage tanks and a raw water pond.

To develop the processing facility, Search Minerals has entered into a partnership with the Atlantic Canada Opportunities Agency (ACOA) and the Research & Development Corporation of Newfoundland and Labrador (RDC) to develop and operate a pilot plant to process **Foxtrot** ore. The results from the pilot plant work will be used in designing a full scale processing plant for the mine operations. It should be noted that the process plant components described below is a proprietary system developed by Search. It is known as the “**Search Direct Extraction Process**” and eliminates the grinding, flotation, and magnetic and gravity separation from the processes normally involved in REE extraction. A key feature of this process is that there will be no liquid tailings generated. The residue will be dry and will be stacked on site, thus eliminating the need for a conventional tailings pond or dedicated tailings storage facility.

The pilot plant project is being undertaken by SGS Canada on behalf of Search and has two phases: a bench scale program and a continuous pilot-plant program.

To date the bench scale program has produced the following results:

- The leachability of the **Foxtrot** material by the **Search Direct Extraction Process** has been confirmed.
- The removal of uranium from the rare earth leach solution by ion exchange has been demonstrated. This will provide for low levels of uranium in the final mixed rare earth oxide for refining.
- The removal of zinc as zinc sulfide precipitate has been demonstrated. This will provide for low levels of zinc in the final mixed rare earth oxide for refining.

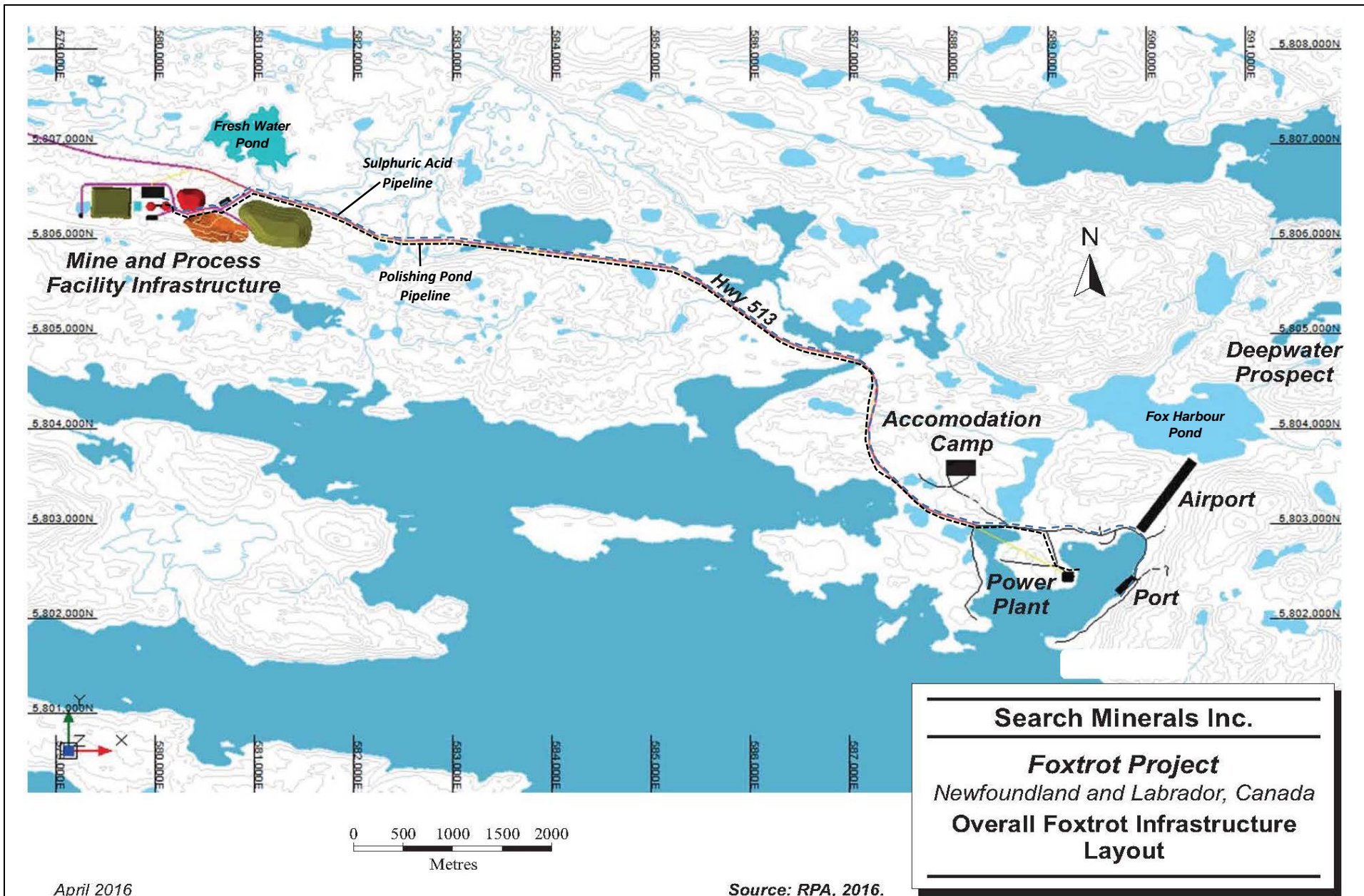

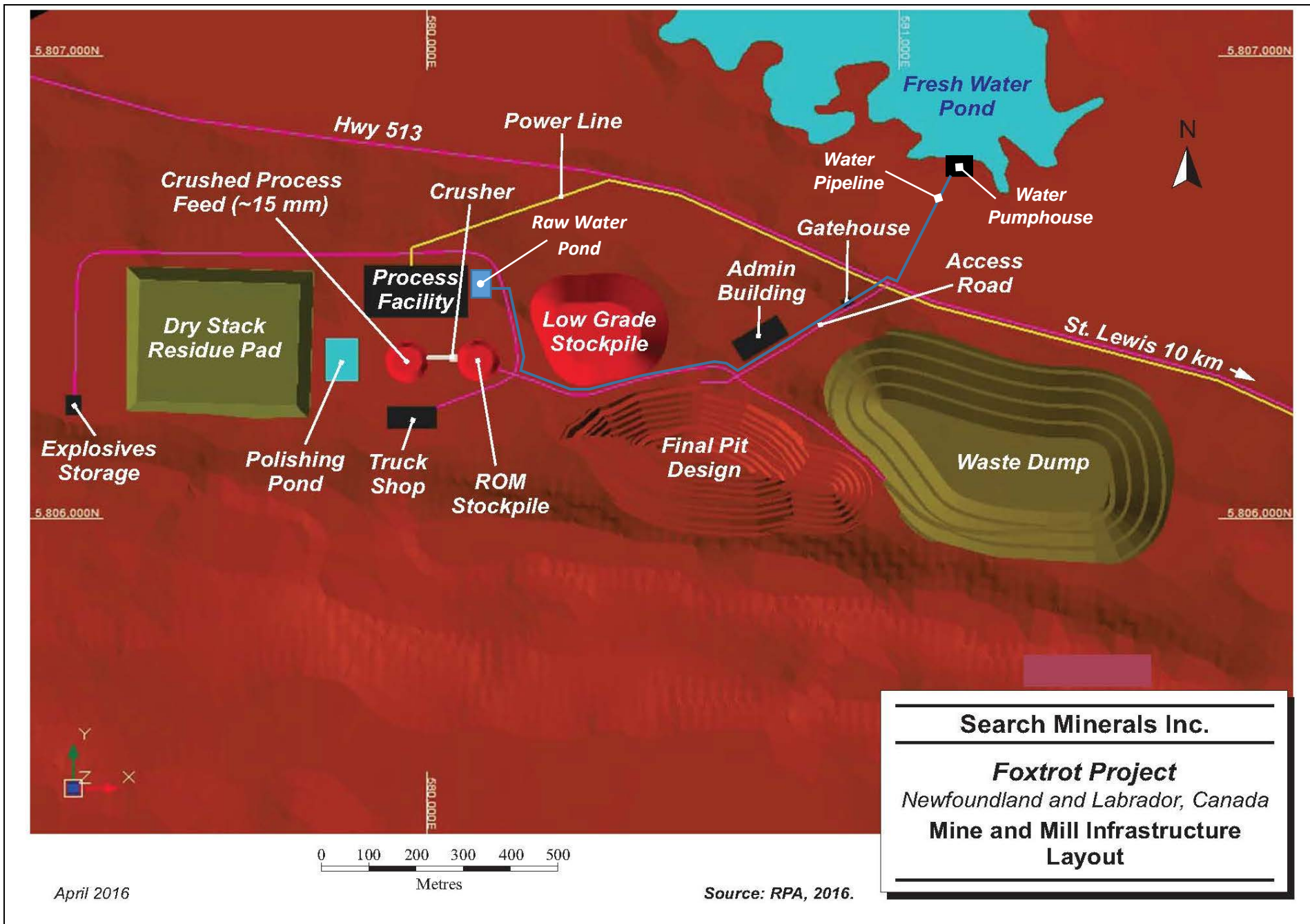

It is anticipated that 1000 tpd of ROM will result in 10 tpd of REO product or 3650 tonnes per year. This will result in approximately 146 container loads of REO product being transported from the site per year (approximately 12 loads per month). The material will be transported over the existing highway road network.

The ore processing is described in the following sections.

3.3.2.1 Ore Preparation

The purpose is to mine and crush the ore to a size of 100% passing 3.45 mm, while minimizing the fines generated. The sized feed is approaching the minimum size possible for a dry crushing circuit.

3.3.2.2 Mixing and Acid Baking

The purpose of the mixing stage is to mix the crushed ore with concentrated (93%) sulphuric acid at a rate of 100 kg of acid for every tonne of ore. This mixture will then be heated and maintained at 200°C for 90 minutes. This section of the plant operates continuously for 24 hours a day.

This is achieved by:

- A pug mixer is used to intimately mix the acid with the ore. A recycled filter cake from the later Secondary Th Removal stage is also added to pug mill to minimize REE losses.
- A preheater is used to raise the temperature of the mixture to 200°C.
- The heated mixture is then transferred to a refractory lined bin to provide the 90 minutes at temperature for the acid to react.
- The hot gases evolved from the pre-heating and refractory lined bin are contained and scrubbed in a caustic scrubber.

3.3.2.3 Water Leaching, Impurity Removal and REE Precipitation

The purpose of the water leaching stage is to provide the time, agitation and temperature to leach the metals dissolved by the acid bake. The slurry is then neutralized with Magnesium Carbonate ($MgCO_3$) slurry to reduce the free acid sufficiently to substantially remove impurities by precipitation onto the leach residue. The leach residue is then separated from the leach solution and the rare earths in that solution are precipitated by further neutralization with Sodium Carbonate ($NaCO_3$) solution.

The water leaching, impurity removal and REE precipitation are achieved by:

- Hot acid baked ore is mixed with hot water in 3 large gravity overflow Water Leach Tanks providing 24-hour residence time and intense mixing required for the water leach.
- Wash filtrates from downstream in this area are recycled to the water leach to maximize the washing of products, minimizing the dilution of the leach liquor and minimizing the overall water consumption and disposal. These flows are supplemented by additional raw water supply.



- The liquid feeds to the water leach are heated by a combination of heat recovery from the REE precipitation overflow liquor prior to disposal and steam heating.
- The last of the Water Leach Tanks overflows to the first of the 2 smaller Impurity Removal Tanks where the controlled addition of $MgCO_3$ solution neutralizes the free acid to achieve a solution pH of 3.85. As the pH is raised to this level and over the 2-hour residence time, the majority of the iron (Fe), aluminum (Al) and thorium (Th) impurities are precipitated onto the leach residue.
- The relatively coarse leach residue is thickened as feed for a vacuum belt filter. On the vacuum belt filter the solids are thoroughly washed to maximize the recovery of REE. The resultant is transferred to a bin and dumped into a dump truck for dry disposal to a lined dry tailings storage facility.
- The overflow from the thickener is filtered with a pre-coated polishing filter to ensure none of the ore fines or precipitated impurities are contaminating the solution and thus maximizing the purity of the REE precipitation product.
- The solids free solution is mixed with a Na_2CO_3 solution to preferentially precipitate RE carbonates from the liquor.
- The precipitated solids are thickened and two thirds of these solids are recycled as seed for the precipitation process. The remaining one third are filtered and washed on a diaphragm filter. The resultant solids are transferred to a belt conveyor to one of the two HCL Re-leach tanks for further processing.
- The overflow from the thickener is filtered with a pre-coated polishing filter to ensure none of the precipitated product is lost and the liquor is then disposed to the sea via a pipeline.

The disposed liquor is estimated by mass balance to be 70m³/h. All discharges will comply with the federal *Metal Mining Effluent Regulations* and the provincial *Water and Sewer Regulations* and discharged through a discharge pipe to St. Lewis Harbour. The details of the discharge pipe and route requires further engineering study.

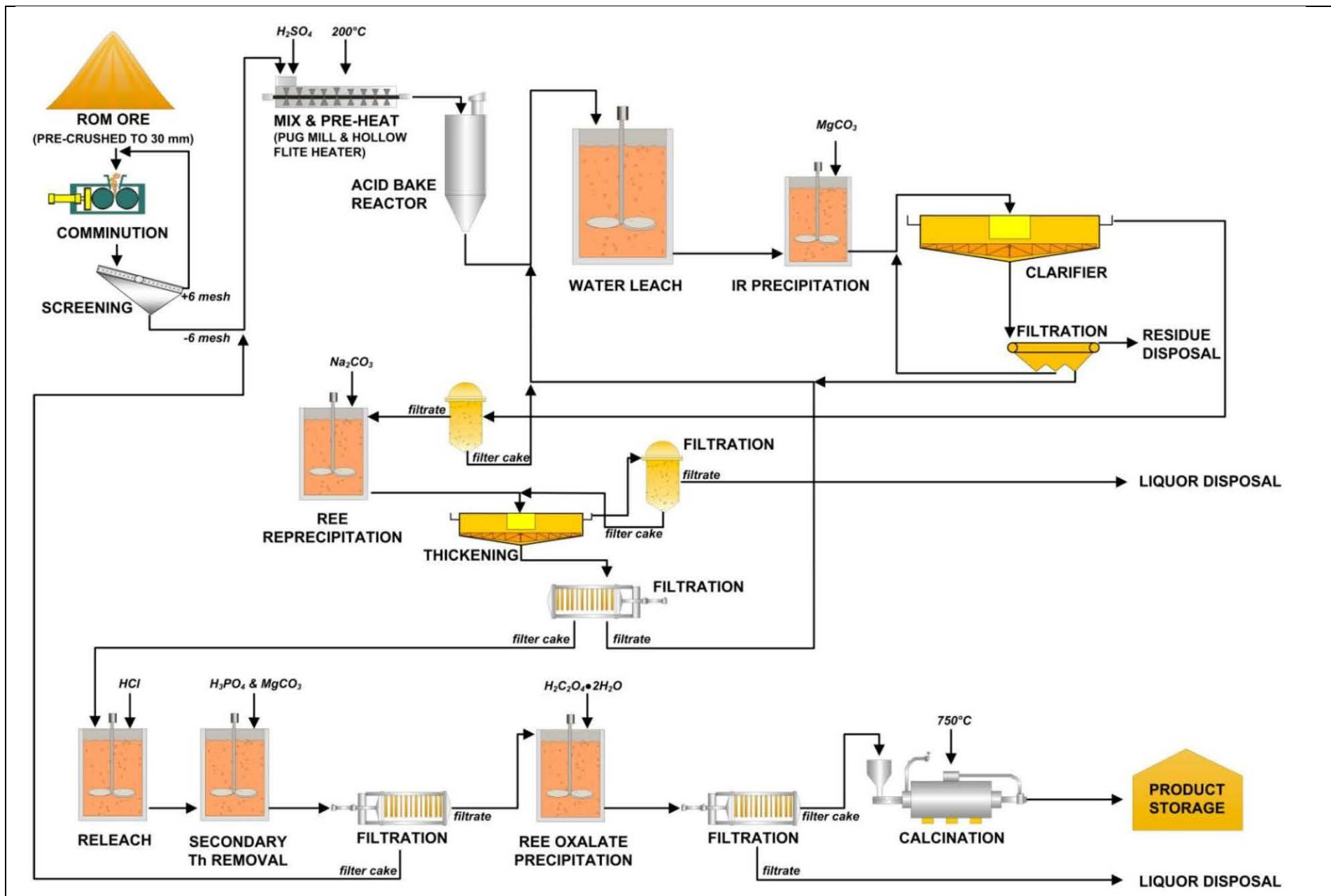

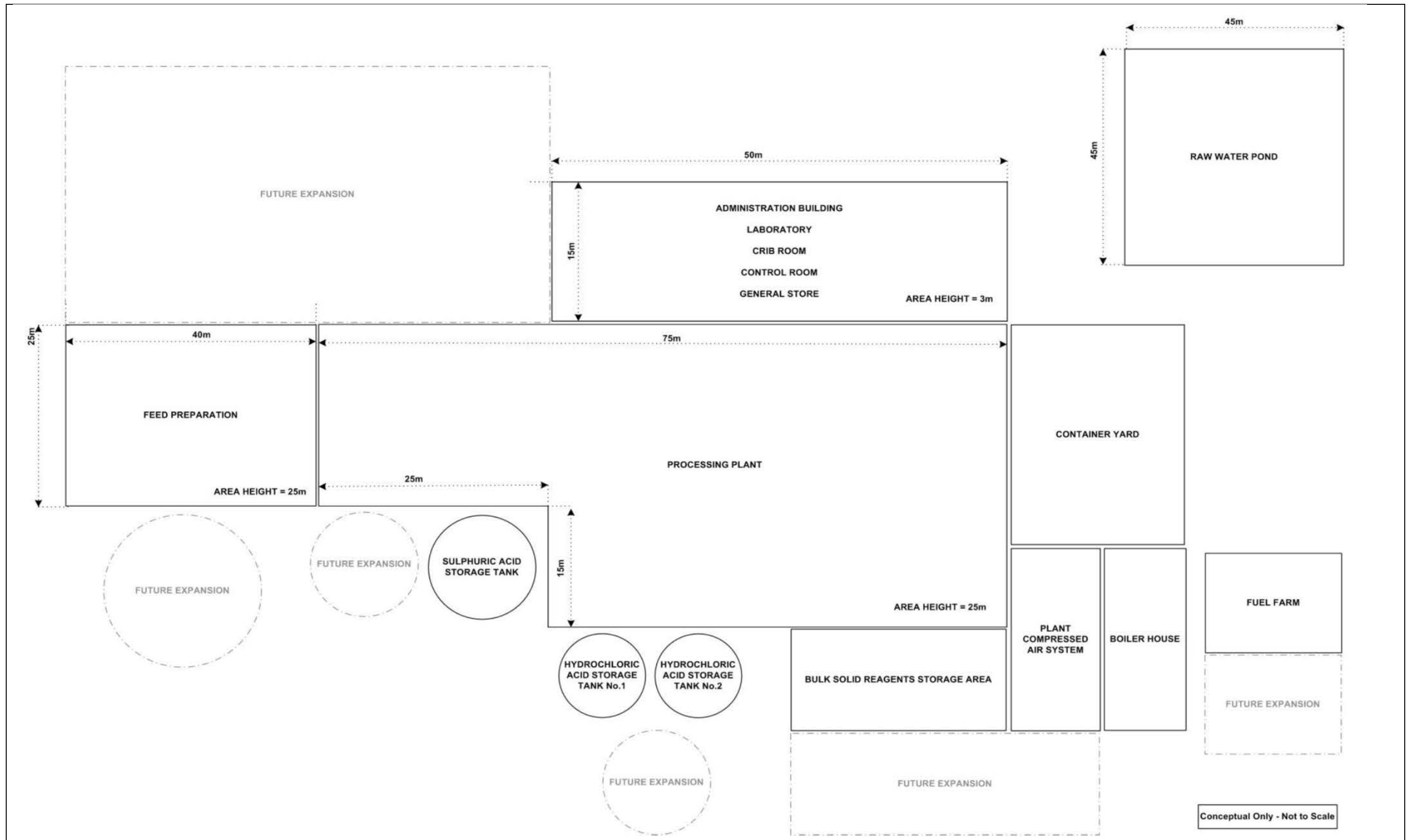

Conceptual Only - Not to Scale

Figure 7 – Conceptual Processing Facility Layout

3.3.2.4 Re-leach and Precipitation

The purpose of this step is to further purify the RE carbonate product by re-leaching in hydrogen chloride thorium (Th), a second Th removal step and selectively re-precipitating as RE oxalates. This section of the processing facility operates 24 hours a day, but processes the solids as an 8-hour batch from the continuous sections. This is achieved by:

- An 8-hour batch of REE Precipitation filter cake is allowed to accumulate in one of the two HCL Re-leach tanks. The cake is constantly re-pulped by continually adding a minimal level of 33% HCL. At the change of shift the REE Precipitation Filter cake is diverted to the other HCL Re-leach tank that has been emptied on the previous shift.
- Additional 33% HCL is added to the batch now being processed to reach an excess of 10g/L acid and the tank is agitated under these conditions for an hour as the HCL Re-leach step.
- After one hour, the Chloride Tails Filter cake from the previous batch is added and the tank is agitated to reduce the free acid levels and re-leach some of the value metals.
- A small quantity of H₃PO₄ is added to this tank to assist in lowering the pH required to remove Th (and consequently reducing REE losses). Then sufficient MgCO₃ slurry is added to further neutralize the solution to achieve a solution pH of 3.8. As the pH is raised to this level and over the 2-hour residence time, the majority of the iron (Fe), aluminum (Al) and thorium (Th) impurities are precipitated onto the re-leach residue.
- The resultant slurry is filtered through a pre-coated diaphragm filter. The solids are washed, air dried and dumped into a transportable hopper. Once full, the hopper is rolled and hoisted into a position for a metered return to the Acid Bake pug mixer. The solution is collected in the RE Oxalate Precipitation Tank.
- Solids from the previous batch are re-pulped into the high strength RE chloride solution, and then an oxalic acid solution is mixed into the solution to preferentially precipitate RE oxalate from the liquor.
- The precipitated solids are filtered and two thirds of these solids are reserved and used as seed for the next batch. The remaining third are washed and air dried on the diaphragm filter and dumped into a calcination hopper for further processing.
- The filtrate is collected in the Chloride Tails Tank, further neutralized with MgCO₃ slurry and filtered with the same filter used to filter the second Th removal step. The filter cake from this filter is used to neutralize the free acid from the HCL Re-leach. The filtrate is pumped directly into the RE Precipitation overflow stream and disposed of by pipeline to the sea.

The majority of the tanks in this section of the plant are covered and vented to a HCL scrubbing plant.



3.3.2.5 Calcination

The purpose is to calcine the RE oxalate precipitate at 750°C to break down to the RE oxides, cool, transfer to 1t bulk bags, weigh and sample for quality control and then transfer the bags to a container ready for export.

This is achieved by:

- A calcination hopper loosely filled with oxalate filter cake is wheeled into a 450KW oven and a pre-programmed heating/cooling cycle is activated to heat the contents to 750°C and hold them at this temperature for 4 hours and then allow the contents to cool.
- Once the hopper is cool, the hopper can be removed from the oven, hoisted into a packaging platform and used to give a metered and measured feed into 1 m³ bulk bags.
- Packaging is largely a manual operation of hanging the bag, initiating feed to near desired weight, jogging the feeder to achieve desired weight, sampling for analysis and custody transfer and affixing the relevant identifying documentation. The bag can then be closed, unhooked from the packaging frame and taken by forklift to a shipping area and thence shipped by truck to market.

Table 3 shows what are the anticipated differences/benefits are between the traditional process and the proprietary (Search) process will be.

Table 3 Anticipated Difference in Processes

Compare Old and New Metallurgical Process for Foxtrot			
	Traditional	Search	Benefit
Rock Treatment	Crush and Grind to .105mm	Crush to 3.45mm	Save grinding cost and process
Upgrading process	Use flotation, gravity and magnetic separation	None	Save beneficiation cost and process. Flotation, gravity and magnetic separation not required
Primary Chemical Treatment	Acid bake, water leach, purification, oxalate precipitation	Acid bake, water leach, purification, carbonate precipitation	Carbonate precipitation is much cheaper than oxalate
RE precipitate	55.58% TREO	32.08% TREO	Lower grade but then must purify
Secondary Chemical Treatment	None	Acid re-leach, purification, precipitation and calcination	Very small circuit due to high grade of concentrate
Final product	55.58% TREO	98.99% TREO (High grade RE Oxide)	Meets Rare Earth Refinery needs-greater than 92% TREO and contains less than 10g/t of Thorium

The results of the continuous pilot plant operation are expected to be available by Q2 of 2017 and will be included in subsequent environmental regulatory document submissions.

3.3.2.6 Process Reagents

The purpose is to receive, store and prepare reagents for use at the site most of which are delivered through the existing port facilities. The bulk shipments of the higher volume chemicals (e.g. sulphuric acid, magnesium carbonate, and hydrochloric acid) will be delivered via vessel to storage tanks to be constructed at the existing wharf facility in St. Lewis. The chemicals required at the Project site will be transferred from the wharf storage tanks to smaller day tanks at the site using dedicated transfer trucks. The rest of the reagents will be delivered to the site by truck using the existing road infrastructure. The number of transfers will be determined based on the process rate and process efficiency.

Typical large scale reagents include:

- Sulphuric Acid.
- Magnesium Carbonate.
- Filter Aid.
- Flocculant.
- Sodium Carbonate.
- Phosphoric Acid.
- Sodium Hydroxide.
- Oxalic Acid.
- Hydrochloric Acid.

Table 4 provides the estimated volumes of the major consumables for the annual production of the Project.

Table 4 Major Project Consumables and Estimated Annual Usage

Consumable	Annual Usage (tpa)
Sulphuric acid	18,250
Magnesium Carbonate	10,200
Hydrochloric Acid	9,800
Sodium Carbonate	4,600
Oxalic Acid	2,000
Filter Aid	270
Phosphoric Acid	210
Sodium Hydroxide	60
Flocculant	2

3.3.3 Laboratory

The purpose of the laboratory is to provide grade control and metallurgical assays services for the project. The laboratory will be equipped with sample preparation, screening, ore digestion and analysis facilities. The primary means of analysis is by inductively couple plasma optical emission spectroscopy (CP-OES) and mass spectrometry (ICP-MS). In all likelihood this facility will be located in the operations building or directly in the processing facility.

3.3.4 Utilities and Services

The purpose is to provide the utilities to support the operation and maintenance of the main processing facilities. This includes the provision and distribution of differing grades of water and compressed air, building heating and provision of power. This is achieved by:

- Raw water will be sourced from a Fresh Water Pond, (**Figure 5**) via a new remote pump station and pipeline, a distance of approximately 2 km and a diameter between 400 to 600 mm, to a raw water pond located on the Project site. The engineering for the pumping system has not been completed to date. It is anticipated that a heated pump house will be constructed along the southern side of Fresh Water Pond (Figure 5). The pipeline will follow Route 513 for approximately 1.2 km from the Fresh Water Pond to the site.
- The raw water pond (**Figure 5**) will maintain 4 days capacity and a supply of fire water. The raw water pond will be engineered to maximize the depth of the pond and will include low level suction pumping to ensure access below the frozen surface. The raw water will be treated as required and distributed to the process and potable water systems. It is estimated that the Project will require 1,856,452 m³/a of raw water and 4,380 m³/a of potable water which will come from a local surface source (RPA 2016).
- A dedicated fire water pump will be installed to pump water from the Raw Water Pond and will maintain pressure and provides peak flow for the building and area fire protection systems.
- Two air compressors and an air dryer are provided to provide instrument air that is distributed throughout the processing facilities for instruments and hose stations.
- The building will be heated by a diesel fired boiler providing the heat for a circulation of hot water at the ventilation air intakes. This boiler also provides low pressure (LP) steam for use by the process. The boiler package includes water demineralization, boiler feed water treatment and condensate return systems.
- Electrical power will be provided through the Newfoundland and Labrador Hydro (Hydro) grid. Discussions have taken place with Hydro with regard to tying in to the sub-station at St. Lewis. This could require modifications to that facility to increase its capacity and construction of a dedicated transmission line. It is estimated that the Project will require 3.3 mega watts (MW) (RPA 2016). The proposed transmission line will be approximately 12 km in length from the existing

diesel NL Hydro generating station to the Project site and follow along Route 513 from the NL Hydro sub-station to the Project site.

3.3.5 Mobile Equipment

The following mobile equipment will be provided to support the processing facility.

- A 2 tonne forklift with short mast and integral side shifter for reagent and product handling, and to assist with maintenance.
- A front end loader with 9 m³ bucket feeding the ore into the crusher at a rate of 5-6 buckets per hour over the day shift. This loader is also used for dressing and maintaining the dry residue storage facility.
- A highway standard 32t dump truck for transferring dry residue filter cake to the residue storage facility.
- Mobile diesel powered power generator, lighting tower and welder for non-specific maintenance usage.
- Four light vehicles and a small bus for the movement of people and maintenance materials.

3.3.6 Administration Building

The administration building will house the administration offices, engineering and geology offices, first aid area, cafeteria, and wet/dry facility. It may also include the laboratory or alternatively the laboratory will be housed in the plant.

3.3.7 Maintenance Building

This building will house the garage for light and heavy machinery, a machine shop, electrical shop and a welding shop.

3.3.8 Accommodations

While Search will attempt to utilize local labour as much as possible, it is possible that some labour and technical positions will need to be brought in to operate the plant. Search will provide an accommodation facility for such transient personnel. The facility will include rooms, washroom facilities, mess hall, recreation area, etc. Contractors will provide their own accommodation facilities during construction. It is initially anticipated that the construction workers will be accommodated at temporary facilities to be placed at the current Accommodation Camp that Search operates from in St. Lewis (**Figure 4**). It is anticipated that the site will be leased by Search from the current owner.

It is expected that this camp will have a total capacity of approximately 80 people. There will be sleeping rooms, a kitchen/dining facility, clinic, laundry, and basic recreation facilities (RPA 2016). Details of the camp size and number of structures has not been determined at this time and will be included in the Feasibility Study and Conceptual Engineering stages. Workers staying at the construction camp will be

transported from the camp to the worksite using a bus. The number of trips to and from the site will be determined by the number of workers being accommodated at the camp. It may range from 2 to 4 trips to and from the camp site per day. Local workers will use personal vehicles to travel to and from the work site daily.

3.3.9 Port Facilities

Bulk shipments of process chemicals will be shipped to site via an existing wharf located in St. Lewis (**Figure 4**). Photo 1 shows the existing port facilities in St. Lewis. Chemicals required in large volumes (e.g. hydrochloric acid, magnesium carbonate and sulphuric acid) will be delivered to the port by ship and stored on the wharf in dedicated tanks or containers. The chemicals are anticipated to be delivered to the site by truck on an as required basis based on production rates. The 93% Sulphuric acid is anticipated to be delivered in 10,000 dead weight tonnes (DWT) shipments and unloaded to insulated acid tank(s) at the port. There is the potential for one to two tanks to store approximately 11 150 m³ (300,000 US gallons) of sulphuric acid on the south end of the port on land. The tank(s) will be located on land within secondary containment. The chemical will be unloaded through a dedicated pipe system from the ship to the storage tank(s). The sulphuric acid will then be pumped from the storage tank(s) at the port to the site to maintain the level in a small storage tank at the processing facility. The sulphuric acid will be pumped through an insulated and heat traced pipeline, approximately 12.5 km long, from the port to the Project site for along Route 513. The acid from the on-site tank will be dosed directly into the process.

Therefore, upgrades will be required at the port/wharf for the location of the tank(s) and truck loading area. The upgrades to the wharf will be included in the Feasibility Study and Conceptual Engineering stages.

The frequency and size of the deliveries by ship will be determined during discussion between Search Minerals and the supplier. The chemical supplier will be responsible for the delivery vessel and will most likely be through a third party shipper. At this time it is anticipated that there will be one to two deliveries of chemicals through the port per year.

The harbour is currently operated by the Harbour Authority of St. Lewis. To date Search Minerals has had high level discussions with the Harbour Authority regarding the Project and its potential use of the port facilities (personal communication, Greg Andrews, 26 May 2017).



Photo 1 The port facilities in St. Lewis, NL.

Source: <https://mw2.google.com/mw-panoramio/photos/medium/39315862.jpg>

3.4 Mining Operations

The operations of the open pit and the underground mine are outlined in the following sections.

3.4.1 Open Pit Mining

The open pit mining production rate will be approximately 360,000 tonnes per annum or 2000 tonnes per day of REE bearing material over a period of six months per year (May to October). Mining of mineralized material and waste (no pre-stripping of overburden is required, as the deposit is exposed on surface) would be carried out by contractors. A cross-section of the open-pit is shown in **Figure 8** indicating how the ore will be extracted for each bench.

Run-of-mine mineralized material will be placed in a stockpile and fed into a crusher using a front-end loader. All ROM mineralized material will be crushed to 100% passing 15 mm and placed in a feed stockpile adjacent to the process facility.

Mining will be carried out using a conventional open pit method consisting of the following activities:

- Drilling performed by conventional production drills.
- Blasting using ANFO (ammonium-nitrate fuel oil) and a down-hole delay initiation system.
- Loading and hauling operations performed with hydraulic shovel, front-end loader, and rigid frame haulage trucks.

The production equipment will be supported by bulldozers, graders, and water trucks. Search Minerals will supervise the overall mining operation with its own employees including mining engineers, geologists, surveyors, and support staff.

3.4.2 Underground Mining

The production for the underground mine is assumed to be 360,000 tpa, or 1,000 tpd, of REE bearing material and will operate year round. The underground mine will be owner-operated.

The underground mining method will be long hole mining with principally transverse accesses from the deposit footwall through to the hanging wall. Mining will start at the topmost level and progress in a top down fashion with each level being completely mined before starting the next level. The main decline will ramp down from the starter pit to the first level of mining.

Cemented rock fill (CRF) will be placed in all stopes. The bottom 10 m of each stope will be filled with CRF having 8% binder content while the remainder of the stope will be filled with 4% binder content CRF. The rock fill will come from both underground development waste and open pit waste.

A pillar of 35 m in height will be left under the bottom of the pit, which can be recovered by drilling upward from the first level of mining at the end of the Life of Mine (LOM).

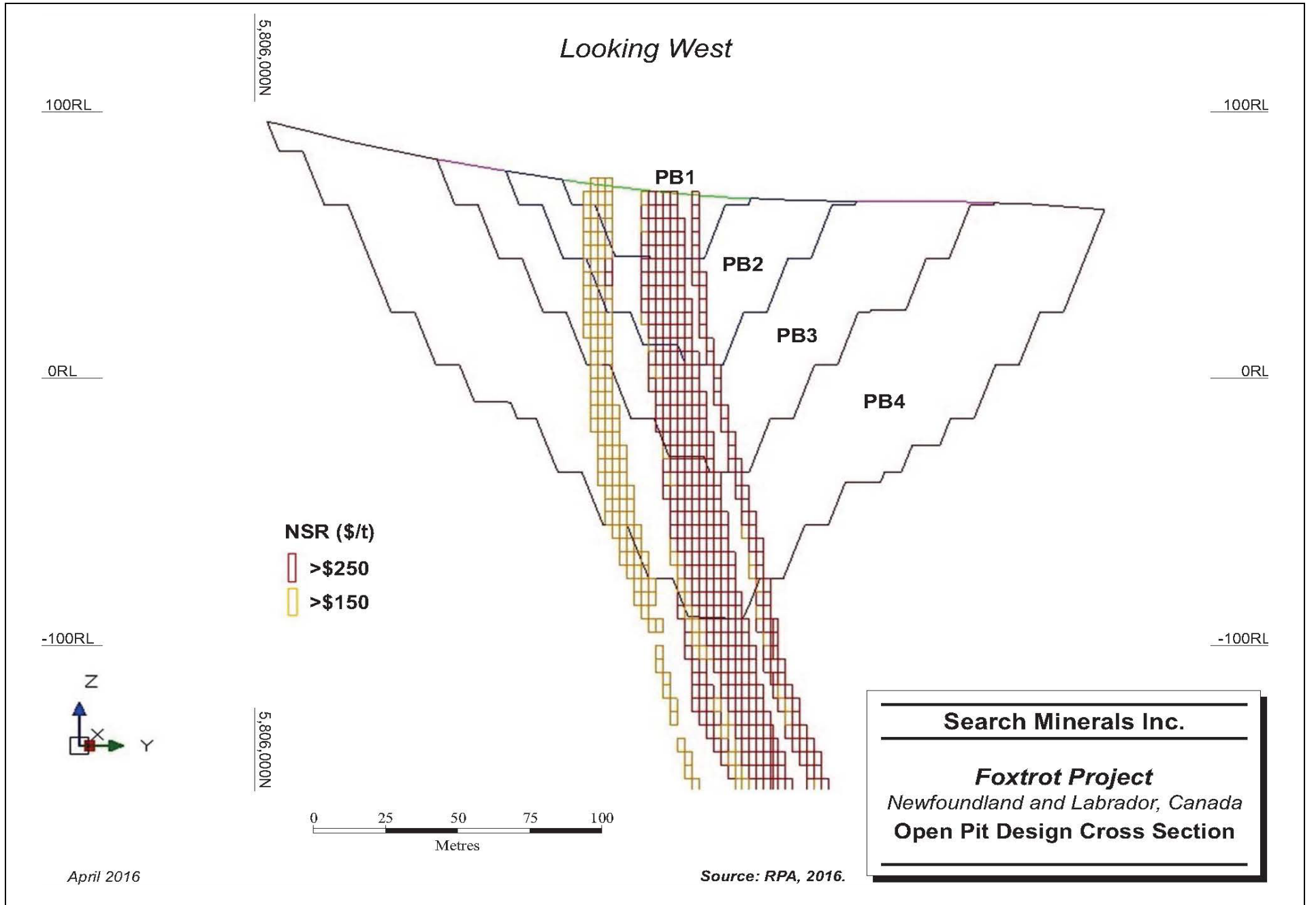

Mining will incorporate the following activities:

- Lateral development performed with hydraulic jumbos (drilling) and mechanical bolters (ground support).
- Vertical development performed with Alimak (vent raise/second egress, fill raise) and V-30 type drill (slot raises).
- Production drilling will be carried out with long hole top-hammer drills.
- Blasting using Ammonium Nitrate/Fuel Oil (ANFO) in development activities, and bulk emulsion (with electronic caps) in production operations.
- Stationary equipment for underground mining would consist of the following:
 - Main fan and propane heating system, and secondary fans for ventilation requirements.
 - Air Compressor.
 - Mine dewatering pumps located underground at the main pumping stations, and at development headings.

3.4.3 Waste Dump and Low- Grade Stockpile

A waste dump and low-grade stockpile will be constructed to receive all non-process feed materials within the final open pit. As shown on **Figure 5** the waste dump and low-grade stockpile are located to the east and north of the open pit, respectively. The waste dump has capacity for approximately 24.0 metric tonnes (mt) and is anticipated to reach a height of 80 m.

The low grade stockpile has a capacity of 1.9 Mt and will be built using one 20 m lift. Material with a Net Smelter Return (NSR) value lower than \$150/t is sent to the waste dump. Material with an NSR value lower than \$250/t elevated cut-off grade and above \$150/t is sent to the low grade stockpile with a potential to process in the future.

3.5 Waste, Emissions, and Discharges

The wastes, emissions and discharges associated with the Project are indicated below along with standard and relevant practices and mitigative measures to minimize and manage them.

- Surface runoff controls will be in place to ensure that precipitation and surface runoff is managed appropriately. Surface runoff and runoff from facilities will be directed to sedimentation basins via drainage ditches as necessary and feasible. Overflow from sedimentation basins, if any, will be directed to natural drainage. A sump at the lowest elevation of the pit will pump water to a sedimentation pond(s) as needed. As the pit is excavated, the sump will be re-established on each bench.

The liquid discharge from the processing plant will be discharged to the polishing pond on the Project site and then discharged via a pipeline to the ocean at St. Lewis inlet near the existing NL Hydro generating plant.

All liquid discharges from the Project will comply with the provincial *Water and Sewer Regulations* and the Federal *Metal Mining Effluent Regulations*.

- Impacted water collected from the stockpiles, waste dump and the open pit will be sent to the polishing pond for treatment prior to release from the Project site;
- Combustion and process air emissions: all vehicles and equipment will be equipped with proper exhaust systems and emissions will be reduced through proper maintenance and inspection practices to reduce idling as practical. Process emissions will be controlled by proper operations and by in-stack air pollution equipment as necessary. All air emissions from the Project will comply with the provincial *Air Pollution Control Regulations*.
- Fugitive dust: dust emissions will be controlled by adjusting the crushing rate and the blast size and, if necessary, the application of water obtained from the raw water system or the sedimentation pond. To minimize the generation of dust, the working areas and laydown areas will be covered with blasted rock. Dust generated by truck movement along the site roads will be minimized by speed control, proper truck loading, application of dust suppressants (including water) and proper road construction.
- Noise and vibrations: Noise and vibrations will be generated from the operation of heavy machinery (e.g. haul trucks) and the use of explosives for the development mine pit. Attenuation (distance between the source and the receptor) and vertical separation will be the primary means of control of noise and vibrations resulting from the operation.
- Solid waste generated on the site will be limited to office and domestic waste. All solid waste will be properly collected and stored until such time that it can be transported to a provincially approved waste disposal facility. Currently there are approved waste disposal sites at St. Lewis and Port Hope Simpson. Plans are under consideration for a regional facility to service the area. Approval will be sought from the owners/operators of a site before waste from the Project is directed there. Where possible waste materials will be recycled and/ or reused. Mine waste and low grade rock will be stored on site either for processing or for use in reclamation. The following provincial Regulations may apply to waste management/ disposal at and from the Project:
 - *Waste Diversion Regulations*.
 - *Waste Management Regulations*.
- Hazardous waste: waste oil and filters will be removed from the site for proper disposal and recycling. In addition to petroleum products there will be small amounts of solvents for parts cleaning stored on-site. The handling, transportation, storage and use of explosives will be conducted by a licensed contractor employing trained and qualified personnel. The following Regulations will apply to the Project:
 - *Halocarbon Regulations*.

- *Heating Oil Storage Tank System Regulations.*
- *Pesticides Control Regulations.*
- *Storage and Handling of Gasoline and Associated Products Regulations.*
- *Storage of PCB Wastes Regulations.*
- *Used Oil Control Regulations.*
- *Transportation of Dangerous Goods Regulations.*
- *Explosives Regulations.*

3.6 Reclamation

Before a mine is placed into production, the Provincial Department of Natural Resources will require that a rehabilitation and closure plan be submitted for approval. The Department has issued a set of *Guidelines to the Mining Act, Sections 12 and 13* which relate to rehabilitation and closure.

Rehabilitation and Closure Plan

Search will use these guidelines when developing the final Rehabilitation and Closure Plan as well as a progressive reclamation plan. Search is aware that the *Mining Act* requires that a surety be provided to the province for rehabilitation and closure based on the approved plan(s).

The goal of the reclamation plan is to return land and water disturbed by development to a safe and stable condition compatible with the surrounding landscape and final land use.

At closure, all infrastructure will be removed from the site. The open pit will be allowed to flood creating a lake with a variety of shorelines established. Re-contouring of the Waste Rock Storage Facility (WRSF), carried out progressively throughout the Project life, will be completed.

Re-vegetation is typically part of the reclamation but special efforts will be made to the revegetation of the area as it currently has very little vegetation present on the site. Native species will be planted to aid a return to a natural ecosystem reflecting the pre-development site.

Further details of the decommissioning and reclamation of the site will be developed as part of the feasibility study and detailed engineering phases of the Project. Decommissioning of the site is anticipated to take approximately 3 to 5 years after the completion of mine operations.

4 ENVIRONMENTAL SETTING

4.1 Physical Environment

4.1.1 Physical Environment

The area of southern Labrador is in a physiographic region assigned by Sandford and Grant as the Mecatina Plateau (HMM 2015; Doran et al. 2013). This area is rugged with varying topography including undulating hills and barren land areas. Elevation in the Project area ranges from sea level to approximately 100 MASL.

4.1.2 Climate

There is no weather station at the site but Environment Canada has a weather station in Cartwright which is approximately 230km north of the Project area. Table 5 shows a summary of climate data from 1981 to 2010. As noted in this summary the average daily temperature recorded during that period was 0°C, the average annual rainfall was 616.8 mm and the average annual snowfall was 462 cm. Table 6 shows that August is the warmest month with a daily average temperature of 12.7°C and January is the coldest with a daily average temperature of -14.3°C.

Table 5 Climate Data Summary 1981-2010

	Jan	Feb	Mar	Apr	May	June	Jul	Aug	Sept	Oct	Nov	Dec	Year
Temp (°C)													
Daily Average	-14.3	-13.5	-8.7	-1.8	3.3	8.6	12.3	12.7	9	3.7	-2	-8.8	0
Daily Maximum	-9.5	-8.5	-3.6	2.4	7.7	13.8	17.8	18	13.3	6.8	1	-5	4.5
Daily Minimum	-18.9	-18.5	-13.8	-6.1	-1.1	3.4	6.8	7.4	4.6	0.5	-4.9	-12.6	-4.4
Precipitation													
Rainfall(mm)	5.3	9.8	10.5	21.1	47.9	95	100.8	94.1	88.8	88.6	37.6	17.6	616.8
Snowfall(cm)	83.7	82.2	80.7	54.4	205	3	0	0	0.8	12.7	48	76	462
Wind													
Speed (km/hr)	22.5	22.2	22	19.8	17.4	17.1	14.9	14.5	18.3	20.8	23.7	24.3	19.8
Most frequent direction	SW	SW	NW	N	N	N	SW	SW	SW	SW	SW	SW	SW

(Source: Environment Canada, 2015a)

4.1.2.1 Greenhouse Gases

The greenhouse gas emissions anticipated from the Project will result from the use of vehicles and heavy equipment as well as process facility operations. The impact resulting from the greenhouse gases is anticipated to be local in nature.

A preliminary estimate for the greenhouse gas emissions during both the construction and operations phases of the project are presented in Table 6. In total, the estimated greenhouse gas emissions in CO₂e for construction is 50,000 tonnes per year and for operations is 25,000 tonnes per year. The extent of the potential impacts resulting from the greenhouse gas emissions (as measured in CO₂ equivalent units) will be characterized and quantified as the Project engineering progresses to the feasibility stage.

Table 6 Greenhouse gas emissions anticipated from the Project compared to Provincial, Canada and Global Targets.

	NL Targets (Mt)		Canada Targets (Mt) ³		Global Target (Gt) ⁴
	2020 ¹	2030 ²	2020	2030	2030
	8.3	6.3	731	742	34
Construction (Mt)	0.0489	0.0489	0.0489	0.0489	0.0489
(%)	0.59	0.78	0.0067	0.0066	0.00014
Operation (Mt)	0.0252	0.0252	0.0252	0.0252	0.0252
(%)	0.30	0.40	0.0034	0.0034	7.412E-05

- (1) Newfoundland & Labrador Climate Change Strategy (2011)
- (2) 2030 Target - New England Governors / Eastern Canadian Premiers resolution adopted Aug 31, 2015
- (3) Environment and Climate Change Canada Environmental Sustainability Indicators: Progress Toward Canada's Greenhouse Gas Emissions Reduction Target (2016)
- (4) United Nations Framework Convention on Climate Change. Aggregate effect of the intended nationally determined contributions: an update, FCCC/CP/2016/2. May 2016.

4.1.3 Surficial Geology

The distribution and characteristics of the surficial geology of Labrador are largely the result of the last glaciation, the late Wisconsinan (25,000 – 10,000 yrs Before Present (BP)), coupled with influences from pre-existing bedrock topography and lithologies. Ice flow was generally radially outward from the ice divide, or spreading centre, situated in the vicinity of what is now the Smallwood Reservoir. During deglaciation, which was not complete in Labrador until at least 5,000 – 6,000 yrs BP (Nicholson, 1971), ice recession and disintegration occurred from the margins inward. The patterns of drumlinoid features and, to a lesser degree, eskers provide a general sense of ice dynamics during the late Wisconsinan period. The overall pattern of surface drainage, including long, ribbon lakes and irregularly configured rivers, also reflects pre-glacial drainage patterns among the many folds and fractures within underlying bedrock.

The Project area surficial geology consists of a veneer (less than 1.5m) of till over bedrock. Till consists of a mixture of grain sizes from clay to boulders, and was deposited by glacial action (1997 Government of NL).

Most of the Project site consists of exposed bedrock and drift poor areas. The bedrock in the area is exposed or overlain by thin, discontinuous drift within a larger portion of Labrador. These isolated patches of till and other surficial materials occupy the unexposed bedrock areas.

Areas of exposed bedrock generally exhibit a rugged, ridges or knobby surface expression, typical of the Canadian Shield landscape. Through subglacial erosion, some outcrops have been striated and sculpted into roche moutonees. Local relief is typically less than 150m across the inland plateau areas. The bedrock surface is commonly covered by a thin layer of vegetation consisting of mosses and stunted black spruce (tuckamore) or by peaty organic materials in natural depressions.

4.1.4 Bedrock Geology

Labrador consists of five Pre-Cambrian age geological provinces: Superior, Nain, Churchill, Makkovik and Grenville. Southern Labrador is dominated by the west-northeast trending Grenville Province which contains Lower to Middle Proterozoic age high-grade metamorphic and associated intrusive rocks.

Grenville Province

Much of southern Labrador forms part of the Grenville Province, a linear Proterozoic age remnant mountain belt that extends along the east coast of North America, west of the better known and much younger Appalachian mountains. High-grade gneissic rocks comprise most of the Grenville Province in Labrador, although some metasedimentary and metavolcanic rocks are present at the south end of the Labrador Trough and along the boundary with the Makkovik Province. Similarly to the Nain Province, granite-type plutons also occur within the province.

In the southern portion of the Grenville Province, continental red-beds (iron-rich sedimentary rocks) of the Double Mer Formation are found. These rocks are believed to be related to the formation of the early Paleozoic age Iapetus Ocean, when continental rifting resulted in extensive erosion and deposition at the continental margin. Younger Cambrian age rocks occur in southernmost Labrador, near the Strait of Belle Isle, where they rest unconformably upon Grenville Province intrusive rocks and disconformably (i.e., they have the same orientation as rocks below them) upon Precambrian terrestrial sedimentary rocks and flood basalts. These rocks are characterized as platform deposits and are sedimentary in nature. (AECOM 2013).

4.1.5 Hydrology

There is little direct information regarding the hydrology for the Project site. A stream gauge is located within 75 km northwest of the project on the St. Lewis River (Station # 03QC003). This river is not connected directly to the site hydrology but may provide information to determine the overall hydrology of the site.

There are a number of small ponds located on the Project site that may be impacted by the construction activities ranging in size from approximately 0.01 ha to 0.9 ha in size (**Figure 9**). The identification of which ponds will actually be impacted will be determined during the site engineering.

Based on the topography of the site, the flow of water across the site is in a north to northeast direction towards Russell's Pond and associated stream system on the north side of Route 513. The stream system travels easterly and empties into St. Lewis Inlet.

4.1.6 Hydrogeology

Groundwater quality data in Labrador are limited to sample results from only six communities with public groundwater supplies and two additional communities (Doran *et al.* 2013). No historical groundwater studies were found for the Project site or surrounding areas. Additionally, no groundwater testing has been completed to date related to the mining activities. It is anticipated that the groundwater quality will follow the geochemistry of the host rock.

4.1.7 Air Quality and Noise

4.1.7.1 Air Quality

In Newfoundland and Labrador, air quality is regulated under the Air Pollution Regulations, 2004 promulgated under the Environmental Protection Act (2002) and Environment Canada's Air Quality Health Index (AQHI). The AQHI is calculated based on the relative risks of a combination of common air pollutants known to be harmful to human health. These pollutants are Ozone(O₃), Particulate Matter (PM_{2.5}/PM₁₀) and Nitrogen Dioxide (NO₂).

There are a total of seven air monitoring stations (National Air Pollution Surveillance (NAPS) networking monitoring sites) located in Newfoundland and Labrador.

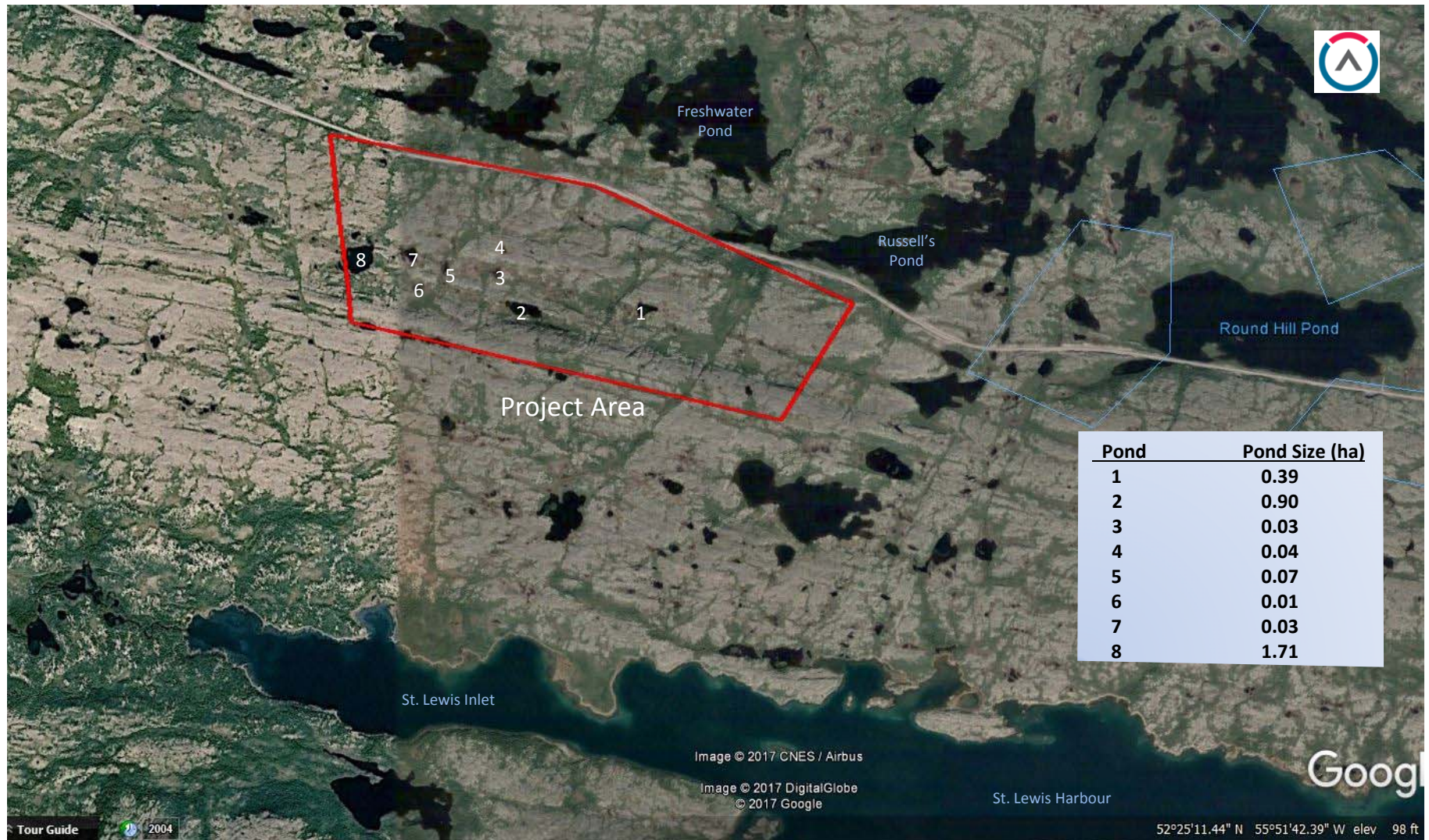

The closest station that measures the air quality parameters noted above is in Grand Falls-Windsor, which is approximately 385 km south. The Grand Falls-Windsor station monitors the ambient levels of Sulphur Dioxide(SO₂), oxides of Nitrogen (NO_x), NO₂, Carbon Monoxide (CO), Oxone(O₃) and Particulate Matter (PM_{2.5}) on a continuous basis. (GoC, 2015).

Based on a review of the AQHI index on November 15, 2015, the area for Grand Falls-Windsor was considered low risk (Government of Canada, 2015).

Based on the monitoring results and the conclusion drawn regarding the low risk at the Grand Falls-Windsor area, it is concluded that, due to the remote nature of the Project site, the risk from an air quality perspective is also low there. Provisions will be made in the Project design to meet all regulatory requirements.

4.1.7.2 Noise

While there have not been any studies done in the Project area on noise levels, it is anticipated that due to the remote nature of the site, existing background noise levels are low. There may be some background noise generated by traffic on the Trans Labrador Highway but this is expected to be minimal. Provisions will be made in the Project design to minimize noise levels generated by the Project.

Noise will be generated by the operation of heavy machinery on site, blasting activities during the development of the open mine, and operation of the processing facility. The noise from the mine operation has the potential to impact both the local wildlife located near the Project site as well as the local residents.

4.2 Biological/Ecological Environment

4.2.1 Vegetation

The Project site is in an area known as the Mid Boreal Forest Ecoregion. This Ecoregion is located entirely in south eastern Labrador, is mostly forested and covers 18,600 km². The landscape is characterized as undulating with numerous rock outcrops.

The Mid Boreal Forest Ecoregion is characterized by part of the boreal forest that stretches across northern Canada. Additional regions such as tundra and peatland are also present. The forest community is not considered productive as plant growth within the ecoregion is slim (PAA 2008). Hardwoods are found in this area, which are mainly non-existent in many subarctic forest communities. Hardwood species consist of White Birch (*Betula papyrifera*) and Trembling Aspen (*Populus tremuloides*) (PAA 2008). Upper slopes are dominated by Black Spruce (*Picea mariana*) forests, Balsam Fir (*Abies balsamea*) and hardwood associates (PAA 2008). Ground cover within the upper slopes and lowland areas range from feathermoss (*Ptilinm* spp.) in dryer areas, to herbaceous plants within fresh to moist communities (PAA 2008). Both recent and past fire activity has shaped the communities (PAA 2008). Additional communities found in this ecoregion include domed bogs and kalmia heaths (PAA 2008). The domed bogs (dominated by sphagnum and heath moss) are found in valleys and are considered the principle

peatland of the region that can range from four to nine meters deep (PAA 2008). Additional herbaceous plants found within this wetland community consist of Pitcher Plants (*Nepenthes* spp), Round-leaved Sundrew (*Drosera rotunifolia*), Bog Rosemary (*Andromeda polifolia*), Bog Laurel (*Kalmia polifolia*) and Labrador Tea (*Ledum* spp). Kalmia heaths (those dominated by small shrubs) are typically found in exposed highland areas that also support similar shrubs found in the bog communities such as Labrador Tea, Sheep Laurel (*Kalmia angustifolia*) and Lowland Blueberry (*Vaccinium* spp.) (PAA 2008).

4.2.2 Mammals

A number of terrestrial mammals and furbearers are associated with the Mid Boreal Forest Ecoregion. Generally, species such as Moose (*Alces alces*), Porcupine (*Erethizon dorsatus*), Lynx (*Lynx canadensis*), Little Brown Bat (*Myotis lucifungus*), Flying Squirrel (*Glaucomys sabrinus*), and Meadow Jumping Mouse (*Zapus hudsonius*), Snowshoe (Arctic) Hare (*Lepus americanus*) (PAA 2008) are found in this Ecoregion.

Caribou (*Rangifer tarandus caribou*) and Northern bog Lemming (*Synaptomys borealis*) are both characteristic of the barrens. Black Bear (*Ursus americanus*), Red Fox (*Vulpes vulpes*), Short-tailed Weasel (*Mustela* spp.) and Wolf (*Canis lupus*) are examples of mammals common in all habitats (PAA, 2008).

Beaver (*Castor Canadensis caecator*) and Muskrats (*Ondatra zibethicus obscurus*), Water Shrew (*Sorex palustris*) and River Otters (*Lontra Canadensis*) occur in ponds, lakes and near rivers (PAA, 2008).

Given the proximity of the Project to many natural features (e.g. woodlands, lakes and watercourses), there is a high likelihood of encountering a number on mammals species within the Project site.

4.2.3 Amphibians and Reptiles

According to the Canadian Herpetological Society (2012) , Newfoundland has fewer native species of amphibians than any other province in Canada, and no known reptiles. Newfoundland and Labrador is home to only eight species of amphibians, two of which are non-native, and six of which are only native Labrador. Within the Mid Boreal Ecoregion, the American Toad (*Anazyrus americanus*) and northern Leopard Frog (*lithobates pipiens*) are found (PAA, 2008).

Based upon the information known at this time, it is uncertain whether populations of amphibians exist within the Project site. If there are low lying areas that are inundated with water during the spring season, following spring freshet, there is a probability that amphibian populations may exist. Smaller wetland communities may be present next to major waterbodies. These may also serve as habitat for these species.

4.2.4 Birds

A large number of birds (400+) have been recorded within the province of Newfoundland and Labrador, including 94 migratory birds according to the Breeding Survey completed by Environment Canada in 2014 (Environment Canada, 2014)

Birds associated with the Mid Boreal Forest Ecoregion are those associated with forested habitat such as the Blackpoll Warbler (*Setophaga striata*), Hermit Thrush (*Catharus guttatus*), Northern Flicker (*Colaptes auratus*), Yellow-bellied Flycatcher (*Empidonax flaviventris*), Boreal Chickadee (*Poecile hudonicus*), Fox Sparrow (*Passerella iliaca*), White Throated Sparrow (*Zonotrichia albicollis*) and Northern Hawk Owl (*Surnia ulula*) (PAA,2008).

Birds associated with marine environments include Greater Yellowlegs (*Tringa melanoleuca*), Common Snipe (*Gallinago gallinago*), Belted Kingfisher (*Magaceryle alcyon*), Canada Goose (*Branta canadensis*), Red Breasted Merganser (*Mergus serrator*), Red-necked Phalarope (*Phalaropus lobatus*) (PAA,2008).

According to Environment Canada, there are no Migratory Bird Sanctuaries (MBS) within the general area of the Project. Similarly, according to Nature Canada and Bird Studies Canada, there are no Important Bird Areas (IBA) within the Project area (Bird Studies Canada and Nature Canada (BSCNC, undated). The closest IBA is approximately 24 km south of the Project site and identified as the St. Peter's Bay, Mary's Harbour IBA. Harlequin Ducks (*Histrionicus histrionicus*) (designated as nationally endangered) have been observed in relatively large numbers around the inlets and islands of St. Peter's Bay; it is also a moulting area for Common Eiders (*Somateria mollissima*) (BSCNC, 2015). It is considered continentally significant under IBA criteria, and its congregation status is considered significant (BSCNC, undated).

4.2.5 Fish and Fish Habitat

There are a number of rivers, lakes and ponds in the Project area that supply habitat to a number of fish species with the most common possible species being: Arctic Char (*Salvelinus alpinus*), Atlantic Salmon (**Salmo Linnaeus**), Three-spine and nine spine sticklebacks (*Gasterosteus Linnaeus;Pungitius Coste*), Brook Trout (*Salvelinus fontinalis*), Rainbow Smelt (*Osmerus mordax*), Longnose Sucker (*Catostomus catostomus*), White Sucker (*Catostomus commersonii*) and Northern Pike (*Esox Lucius*) (PAA,2008).

Given the Project site proximity to watercourses, depending on design and discharge requirements, there may be associated impacts to waterbodies that contain fish populations. Discussions will be held with Fisheries and Oceans Canada to determine what the requirements will be under the *Fisheries Act* once the environmental assessment and the Project design proceeds further.

4.2.6 Species at Risk (SAR)

There are a total of 40 Species at Risk (SAR's) listed in the province of Newfoundland and Labrador and a total of 29 species that are listed as per Schedule 1 federal *Species at Risk Act* (SARA) (Government of Canada 2015b). Based on a review of their habitat ranges, according to provincial Environment and Conservation, Wildlife Division, documents and COSEWIC a total of 14 species have ranges within the Project area (Appendix A).

It is noted that SARA establishes Schedule 1 as the official list of wildlife SAR's, which are identified as extirpated, endangered, threatened or of special concern. Those listed as threatened or endangered are

provided protection on a species and habitat level. As such, for the purposes of this Project, only those species identified as Schedule 1 within Newfoundland and Labrador will be considered.

Based on the Project as it is currently perceived, the likelihood of provincially or federally listed SAR's inhabiting the site is moderate-high. Reconnaissance of the Project site will be undertaken before construction begins to document site conditions and habitat suitability.

Based on information available to date there does not appear to be any migratory routes for Woodland Caribou in the Project area.

4.3 Socio-Economic Setting

4.3.1 Demography

As noted above the **Foxtrot** Project is located approximately 10km west of St. Lewis and 36 km east of Port Hope Simpson. St.Lewis and Port Hope Simpson are located in Census division 10 for Newfoundland and Labrador. The Division contains 15 incorporated communities and 5 unincorporated communities in the area south of Lake Melville and as far west as Labrador City and Wabush. The total population for the division in 2011 was 24,111. The communities of Port Hope Simpson and St. Lewis, therefore, made up 2.6% of the population of the Division in 2011.

4.3.1.1 St. Lewis

St. Lewis is a small fishing community on the coast of Labrador. It was formerly known as Fox Harbour and is the most easterly permanent community on the North American mainland. The community enjoys a long and vibrant history as one of the earliest recorded places in all of Labrador by Europeans. The community was settled in the early eighteenth century (by Europeans), the areas sheltered location, proximity to good fishing grounds and seal migration routes made the settlement a desired location for both the European-based migratory, and the native Inuit families who inhabited the south Labrador coast. St. Lewis has been a radar site since 1954 when the American government constructed a radar site as part of the Pinetree Radar System (DEW Line). A Loran C station was operated by the Canadian Coast Guard at St. Lewis. In January 2010 it was announced that the Loran C signal would be terminated and the broadcasting of the Loran C signal ceased in August 2010. Search is currently leasing the Loran C Building for its local operations and core sample storage.

The population of St. Lewis in 2011 was 207, which is down from 252 in 2006—a 17.9% drop in a five-year period.

The median age in 2006 was 37.6 and in 2011 it was 42.9. This is not unlike the province of Newfoundland and Labrador overall where in 2006 the median age was 42.0 and in 2011 it was 44.0.

Unfortunately, the lack of 100% coverage by the long form Census led to the suppression of all Aboriginal identity data in the 2006 Census but it is estimated, based on NunatuKavut membership

information, which some 98% of all residents of St. Lewis are of Inuit origin and most are of contemporary Metis or Inuit-Metis identity.

4.3.1.2 Port Hope Simpson

Port Hope Simpson was founded in 1934 as a logging camp by the Labrador Development company and a subsequent townsite is named for Sir John Hope Simpson, an English Commissioner. Indeed, it was the first company town in Newfoundland and Labrador. The Labrador Development Corporation operated from 1934-1948 providing pit props to Wales.

In 1962 Bowater Paper Company arrived in the area and began logging to provide logs for their pulp and paper mills in Corner Brook and Kent, England. They operated in the area until 1968.

From 1970 to 1992 cod and salmon fishing was the economic mainstay of the area but unemployment prevailed most of the year. In 1992, the cod fishery was closed down altogether. However, many local fishermen made a transition into crab, shrimp and scallop fishing.

The population of Port Hope Simpson was 441 in 2011 which is down from 529 in 2006—a drop of 16.6% in 5 years. Of the 2006 population, 490 people or 92.5% identified as being of Aboriginal identity -- almost all of whom reported Inuit origins and Metis identity in 2006.

The median age in 2011 was 40.4 while in 2006 it was 35.5 which indicates the population is aging. This is not unlike the province of Newfoundland and Labrador overall where in 2006 the median age was 42.0 and in 2011 it was 44.0.

The unemployment rate for the month of May 2006 in Port Hope Simpson for people aged 15 and older was 55.6%. Conversely, the provincial unemployment rate was 18.6%. The employment rate for the entire year of 2005 for people 15 years of age and older was 74.1%. The provincial employment rate during the same year was 63.3%.

4.3.2 Employment and Economy

The employment in St. Lewis and Port Hope Simpson are primarily based on the fishery (and formerly forestry in Port Hope Simpson). These employment opportunities are seasonal. There are also seasonal opportunities in the tourism industry and government services are spread throughout the Region.

The unemployment rate for the month of May 2006 in St. Lewis for people aged 15 and older was 52.0%. Conversely, the provincial unemployment rate was 18.6%. The employment rate for the entire year of 2005 for people 15 years of age and older was 79.5%. The provincial employment rate during the same year was 63.3%.

The unemployment rate for the month of May 2006 in Port Hope Simpson for people aged 15 and older was 55.6%. Conversely, the provincial unemployment rate was 18.6%. The employment rate for the entire year of 2005 for people 15 years of age and older was 74.1%. The provincial employment rate during the same year was 63.3%.

As one can see these unemployment figures are high. Search will attempt where possible to provide employment and business opportunities for the local communities, including where feasible, training. Given that the Trans-Labrador Highway now connects most communities in southern and western Labrador, the **Foxtrot** Mine will be accessible to many Labradorians who may wish to avail of opportunities at the Project.

4.3.3 Transportation

Travel to the mine site from Goose Bay is available via scheduled and charter airplane, helicopter and road. Goose Bay, located 340 km to the northeast is a preferred hub as it is regularly serviced from eastern Canadian cities including Quebec City, Montreal and Halifax. Flight time from the site to Goose Bay by helicopter is approximately two hours, and by plane approximately one hour. The flight time to Newfoundland is approximately half an hour. During the summer of 2016 Provincial Airlines (PAL) operated a flight to St. Lewis from St. John's/St. Anthony on Mondays and departing for St. Anthony/St. John's on Wednesdays.

Road travel from Goose Bay, a distance of approximately 450 km is six hours. The site is also accessible via road to the Strait of Belle Isle and via a short ferry tip to insular Newfoundland.

The community of St. Lewis also has a deep water dock for transportation of materials to and from the site. The harbour is currently operated by the Harbour Authority of St. Lewis.

4.3.4 Other Infrastructure and Services

Both nearby communities of St. Lewis and Port Hope Simpson offer a variety of services as noted below:

Port Hope Simpson

- ATM.
- Highspeed internet.
- Post Office.
- Convenience store.
- Food Service.
- Gasoline.
- Groceries.
- Accommodations.
- Automotive service.
- Hardware/Sports Equipment
- Bakery.
- Clothing.
- Hairdresser/barber.
- Marine Sales/service.
- Snowmobiles/ATV's and motorcycles.

- K-12 school.
- Churches.
- Employment Services.
- Health Clinic.
- NL Dept. of Natural Resources.
- Volunteer Fire Department.

St.Lewis

- Highspeed internet.
- ATM.
- Post office.
- Convenience store.
- Gasoline.
- Groceries.
- Accommodations.
- Bakery.
- School.

- Health Clinic.
- Department of Fisheries and Oceans.
- Church.
- Volunteer Fire Department.

Services spread throughout the region as follows:

Emergency Services

Police.

The RCMP is responsible for policing Southern Labrador. It provides 24-hour services with daily office hours within each detachment. There are three RCMP detachments within the region located in Cartwright, Mary's Harbour and Forteau.

Fire Protection

Trained volunteer firemen throughout the region respond to fire emergencies. Towns are equipped with fire trucks and a variety of fire fighting equipment or have arrangements for service with neighbouring communities.

Medical Services

The Labrador-Grenfell Health Board is responsible for providing health and community services throughout the region. The Labrador South Health Centre is a regional centre that is located in Forteau approximately 200 km southwest of the site.

In closer proximity to the site is the Mary's Harbour Community Clinic. This clinic houses both a physician and dentist that visit every six weeks. On a regular basis the clinic is staffed by three regional nurse practitioners, one community health nurse, one social worker, one personal care attendant and one maintenance repairman.

Ambulance services are available within the communities of L'Anse au Clair to Charlottetown and are accessed by phoning the local clinic.

4.3.5 Recreation and Tourism

4.3.5.1 Parks and Protected Areas

There are no parks, ecological reserves or protected areas within the proposed Project area.

According to the Wilderness and Ecological Reserve Map of Newfoundland and Labrador (DEC, 2009), and Parks and Protected Areas Map (DEC, 2010b), a Marine Protected Area identified as the Gilbert Bay is located approximately 25 km north east of the Project site. This protected area is managed by Fisheries and Oceans Canada. A provincial Park identified as Pinware is located 150km south of the Project site and the Gannett Islands Ecological Reserve is located 170km north (DEC, no date).

The Battle Harbour National Historic site is located in St. Lewis Inlet approximately 13km southeast of the Project site. The site is not accessible by road but is serviced by boat from Mary's Harbour, an approximate one-hour boat ride.

The Red Bay National Historic site is located approximately 120 km southwest of the Project site and is a depiction of the former Basque whaling activity in the area.

Due to the distances of these sites from the Project it is not anticipated that there will be any impact from the construction or operation of the mine and associated facilities.

According to the Labrador Coast Drive Regional Map there is a snowmobile trail which runs close to Port Hope Simpson. The Foxtrot Project will, in all likelihood not have any impact on this trail.

4.3.5.2 Heritage sites, Archaeological Sites and Other Cultural Resources

The Provincial Archaeology Office (PAO) is the regulatory agency for all archaeological activities carried out in the province. The PAO is charged with protecting, preserving, developing, studying, interpreting, and promoting an appreciation of the historic resources of the Province of Newfoundland and Labrador. Historic resources are protected under the Historic Resources Act.

Based on a preliminary review of archaeology sites in Newfoundland and Labrador, some are situated along the shoreline of St. Lewis Inlet (Government of Newfoundland and Labrador, Undated).

No detailed survey has been completed for the Project area. During the Environmental Assessment and design stage for the Project, discussions will be held with the PAO and the local communities to determine the level of survey/study required for the area.

4.3.6 Land Use

4.3.6.1 Aboriginal Land Use

The Aboriginal peoples of Labrador include the Northern Inuit of Nunatsiavut, the Southern Inuit-Métis of NunatuKavut, and the Innu. The Inuit of Labrador are found in several regions on the north coast (i.e., Rigolet, Makkovik, Postville, both administrative capitals of Hopedale and Nain) and are direct descendants of the prehistoric Thule: hunters who spread from Alaska across the circumpolar regions of Canada and Greenland. In 2005, the Nunatsiavut Government was established as a regional government within the province of Newfoundland and Labrador (Nunatsiavut Government Undated). The Labrador Inuit-Metis are found in a number of communities on the central and southern coasts of Labrador (i.e., Happy Valley Goose Bay, Mud Lake, North West River, Cartwright, Paradise River, Black Tickle, Norman Bay, Charlottetown, Pinsent's Arm, Williams Harbour, Port Hope Simpson, St. Lewis, Mary's Harbour and Lodge Bay), where a significant part of the population are derived from European white-Inuit intermarriage (NunatuKavut 2010). Nowadays, Inuit-Metis traditional fishing, hunting and trapping methods still resonate with a number of community members (Pastore, 1997). The Labrador Innu peoples occupy two settlements: Sheshatshiu, near Lake Melville, approximately 330 km northwest of the Project site, and Natuashish, along the northern coast, approximately 530 km north of the Project site.

No official land use maps were identified for the Project area. However, in a document issued by Nunatukavut in 2010 entitled “Unveiling Nunatukavut—Describing the Lands and People of South/Central Labrador”, there are several maps based on Traditional Knowledge that indicate that the mineral district has been used historically for small and big game hunting, trapping, fishing, berrypicking, etc. The maps also show transportation routes that were used to access these activities—these traverse the mineral District. While no historic or archaeological sites were noted in the Project area, a number of existing cabins and tilts were identified in close proximity to the site. The two nearest cabins are located approximately 2.5km to the southwest and 5km to the northeast of the Project site (**Figure 10**). **Figure 10** provides an overview of the cabins, tilts and Inuit Sites as well as uses by First Nations within the area of the Project Site.

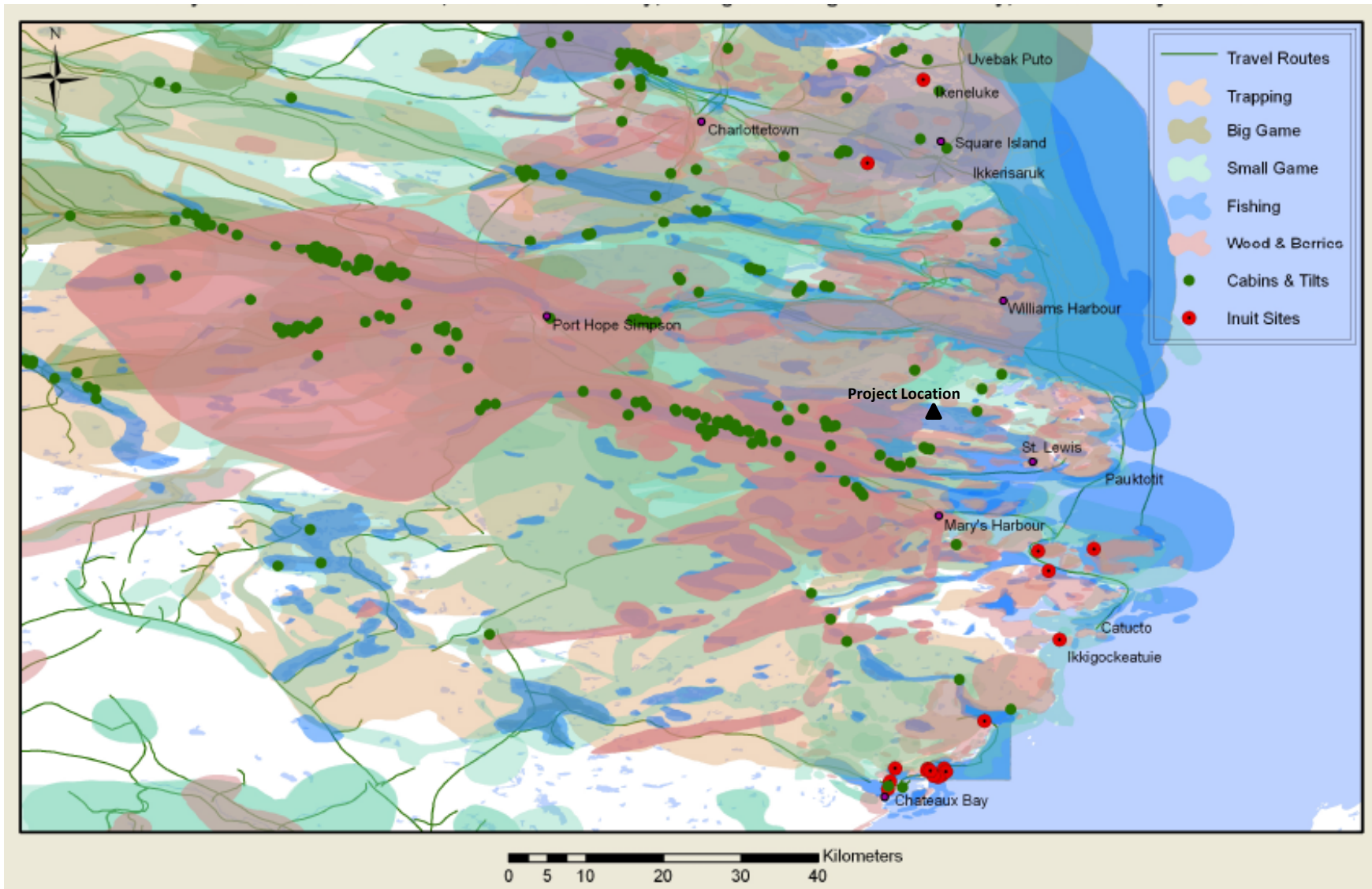

Source: Unveiling NunatiKavut (NunatuKavut 2010)

5 ENVIRONMENTAL EFFECTS

5.1 Effects on Fish and Fish Habitat

Potential impacts on fish and fish habitat will occur in Russell's Pond and the associated stream network. There is potential for sediment to be released from the site to the waterbodies as well as leaks from the vehicles travelling on and to/from the Project site. These will be managed by routine monitoring and Best Management Practices (BMPs).

During the construction of the transmission line to bring power to the site there is also the potential to impact fish and fish habitat during construction. There is one stream crossing and portions of the transmission line may parallel waterbodies along its route. There is the potential for sediment entering the adjacent streams and ponds as well as leaks from the machinery and heavy equipment required for the construction. This portion of the work will be completed and managed by NL Hydro.

The pumping of water from Fresh Water Pond may affect the fish within the pond at the pump intake. Therefore, the intake will be designed to meet the Fisheries and Oceans Canada "Freshwater Intake end-of-Pipe Fish Screen Guideline" to protect the fish within the pond. Additionally, depending on the volume of water removed from the pond, fish habitat may be affected.

Fish and fish habitat could be potentially impacted within St. Lewis Harbour by both the ship(s) used in the transport of chemicals to the Port of St. Lewis and the discharge of mine water from the Project site. The water discharged from the Project site will be treated to meet the *Metals Mining Effluent* (MME) regulations. At the port facilities, secondary containment will be designed to contain potential spills that may occur during the transfer of chemicals from the shipping vessel to the storage container and then for the transfer from the storage container to a transfer truck travelling to the Project site.

5.2 Effects on Marine Plants

There are no environmental effects on marine plants related to the Project. While there will be increased shipping traffic to the existing Port of St. Lewis, this is not expected to result in any additional impacts to the marine plants due to the lower amount of traffic, i.e. one to two additional vessels per year. Construction within the harbour is not anticipated. Construction is expected to be limited to the land portion of the port facilities, therefore not impacting marine plants.

5.3 Effects on Migratory Birds

There is currently no data regarding migratory birds for the Project site. However, potential impacts by the Project on migratory birds may include interference from site lighting and noise, and collisions with transmission lines, buildings or vehicles.

Additional information will be gathered regarding the presence or migratory birds on or near the Project site and the potential impacts as the Project engineering and environmental studies progress through the feasibility phase.

5.4 Effects on Federal Lands

Due to the location of the Project, it is not anticipated that there will be any impacts on federal lands, in a province other than Newfoundland and Labrador or outside of Canada. The project is located approximately 110 km to the Quebec provincial border which is the closest provincial border.

There is the potential to impact federal waters for the transport of chemicals to the Port of St. Lewis by shipping vessel.

5.5 Potential Effects on Aboriginal Peoples

As mentioned earlier in the report, Search Minerals has had a number of discussions with the NunatuKavut regarding the Project and its potential impacts and benefits to the NCC. Search Minerals will develop an Impact and Benefits Agreement (IBA) with the NCC and will include such items as employment and training of the local NCC members. Regarding the Project site itself, there are potential impacts to lands that have been used for such activities as hunting, fishing and berry picking. A Traditional Ecological Knowledge (TEK) study will be undertaken to further understand the potential impacts to the NunatuKavut by the Project.

6 ENGAGEMENT AND CONSULTATION

6.1 Aboriginal and Community Engagement

Search has maintained a close relationship with both the local communities and the NunatuKavut Community Council (NCC) through the start of Project development in 2009. Presently only one Aboriginal Group has been identified to be impacted by the Project development. Search has developed a good working relationship with the NunatuKavut and the local communities.

Search and NCC signed a Minerals Exploration Activities agreement on August 22, 2012 and is still in effect during the development of the Project.

A summary of the engagement is presented in Table 7.

Table 7 Summary of Proponent Engagement with the NunatuKavut

Date	Meeting Summary
June 2015	<ul style="list-style-type: none"> • Discussed the PEA that was released in April 2016 • Presented Powerpoint which was presented at Expo Labrador
June 2016	<ul style="list-style-type: none"> • Discussed next phase of work – metallurgy testing • Presented Powerpoint which was presented at Expo Labrador
November 2016	<ul style="list-style-type: none"> • Site visit with NunatuKavut representative

A summary of the community engagement is presented in Table 8.

Table 8 Summary of Proponent Engagement with the Local Communities

Date	Meeting Summary
June 2015	<ul style="list-style-type: none"> • Discussed the PEA that was released in April 2016 • Presented Powerpoint which was presented at Expo Labrador
June 2016	<ul style="list-style-type: none"> • Discussed next phase of work – metallurgy testing • Presented Powerpoint which was presented at Expo Labrador
November 2016	<ul style="list-style-type: none"> • Site visit with NunatuKavut representative

Many NunatuKavut members live within the communities located near the Project site. Therefore, the dates of the meetings with the NunatuKavut and local communities are similar. Every effort has been made to inform both the local communities and the NCC regarding the Project development. While meetings between Proponent and the communities and the NCC may have occurred on the same day, the same people were not necessarily involved in both meetings.

Some of the issues that have been identified to date during the meetings with the local stakeholders include:

- Safety of the municipal water supply (Fox Harbour Lake).
- Potential for employment with the Project.
- The potential for the waste to be radioactive.
- Concern for the berry picking at locations near the Project site.

Overall, Search has received positive support by both the local communities and the NunatuKavut.



Photo 2 President Russell signing the agreement for the NunatuKavut.

6.2 Government Consultation

Search Minerals has had ongoing discussions with the Newfoundland and Labrador Department of Natural Resources during the development of the **Foxtrot** Project. Initial discussions have begun with a number of other regulatory agencies regarding the environmental permits and approvals necessary for the progression of the Project. Initial discussions with both the provincial and federal environmental assessment agencies was initiated at a meeting on June 24, 2016. At this meeting the Project was introduced to the regulatory agencies and the regulatory pathway forward was outlined by both the provincial and federal representatives. Additionally, the Office of Labrador Affairs (formerly the Labrador

and Aboriginal Affairs Office) was contacted in July 2016 to confirm the Aboriginal Groups to contact and consult with for this Project.

7 SCHEDULE

With the submission of the Environmental Assessment Project Description around the Q3 of 2017 it is anticipated that the Project will receive release from the provincial EA process by the end of 2019. This will give time to receive any critical permits over the winter months of 2020 to commence construction in the spring of 2020. Construction is estimated to take 18-24 months allowing production to start in the fall of 2021 or the spring of 2022. **(Figure 11)**

Reclamation will take place for the 12 months immediately following production. However, progressive reclamation will take place throughout the life of the Project. Once the mine is in operation, the production schedule shown in Table 9 is anticipated.

Table 9 Production Schedule

Period	Open Pit (kt)	Stockpile (kt)	Waste (kt)	Underground (kt)	Total Mined (kt)	Total Processed (kt)
Year 1	361	321	2174	-	2856	361
Year 2	360	259	2549	-	3169	360
Year 3	360	229	5521	-	6110	360
Year 4	360	224	1662	-	2245	360
Year 5	361	264	9087	-	9711	361
Year 6	360	288	2092	-	2740	360
Year 7	360	177	678	-	1215	360
Year 8	292	91	214	68	666	360
Year 9	-	-	-	360	360	360
Year 10	-	-	-	360	360	360
Year 11	-	-	-	360	360	360
Year 12	-	-	-	360	360	360
Year 13	-	-	-	360	360	360
Year 14	-	-	-	170	170	170
Total	2,813	1,853	23,977	2,037	30,680	4,850

(Source: RPA, 2016)

Foxtrot Mine Development Timeline

SMY:TSX-V

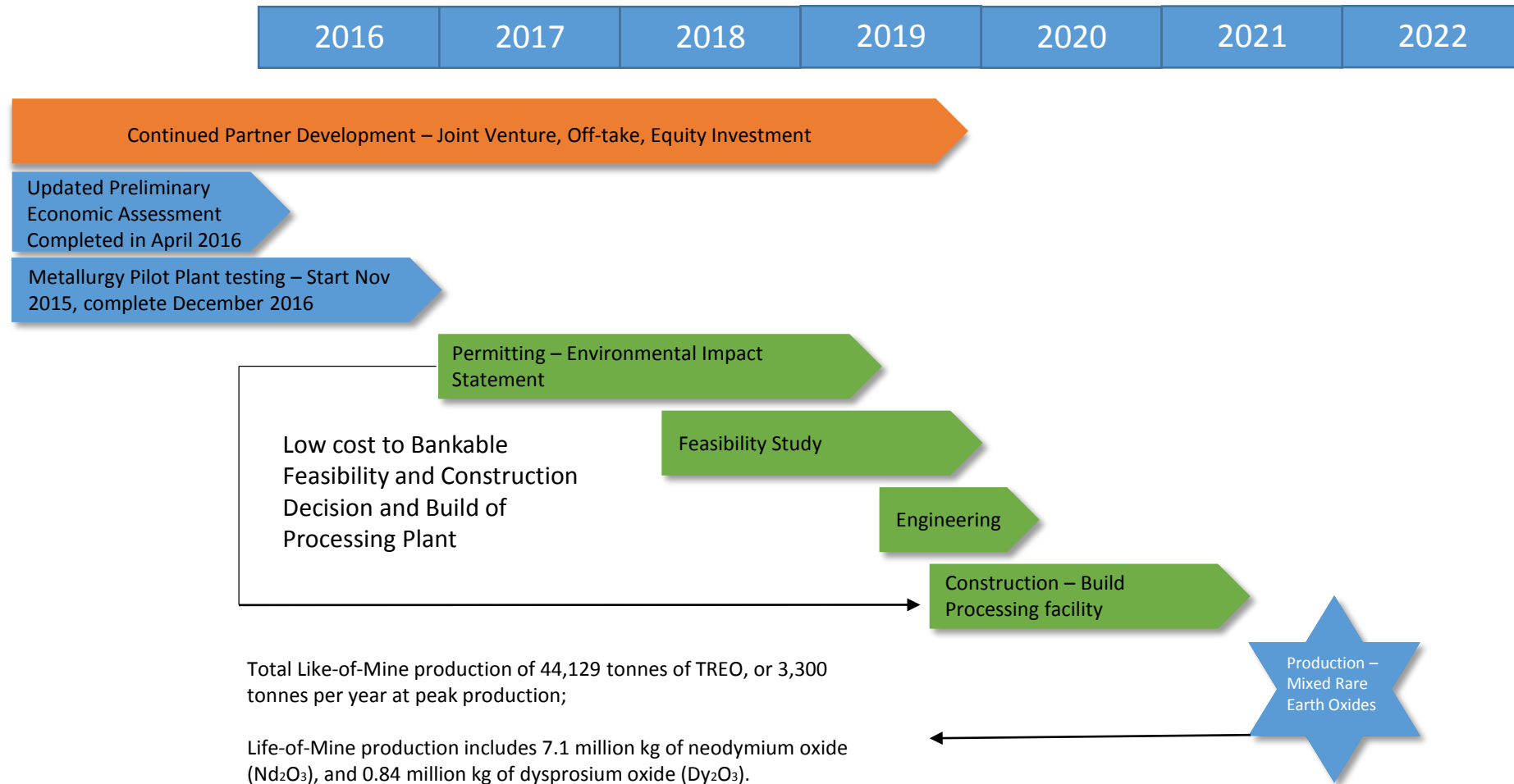

Figure 11 – Foxtrot Mine Development Timeline



7.1.1 Capital Costs

Capital costs for development of the facility is estimated to be \$231.7 M and is broken down as follows:

Table 10 Capital Cost Summary

Area	Capital Cost (\$M)
OP and Surface Infrastructure	\$19.5
Processing	\$72.0
Indirect/Owners	\$28.1
Contingency	\$32.6
Total Initial Capital	\$152.2
Sustaining Capital	\$8.8
Underground Capital	\$56.7
Reclamation and Closure	\$14.0
Total Capital Cost	\$231.7

8 FUNDING

With the exception of the cooperative arrangement with the Atlantic Canada Opportunities Agency (ACOA) and the Newfoundland and Labrador Research Development Corporation (RDC) for the pilot plant noted earlier, the Project capital and operating costs will be funded by the Proponent.

9 REFERENCES

- Bird Studies Canada and Nature Canada (BSCNC) undated. Important Bird Areas Canada interactive map. Accessed October 24, 2016. <http://ibacanada.ca/mapviewer.jsp?lang=EN>
- Doran, N., Cole, J., and Russel, D., 2013. Hydrogeology of Labrador, Prepared by AECOM Canada Ltd., Halifax, Nova Scotia, for the Government of Newfoundland and Labrador Department of Environment and Conservation - Water Resources Management Division
- Environment Canada, 2014. North American Breeding Bird Survey - Canadian Trends Website, Data-version 2012. Environment Canada, Gatineau, Quebec, K1A 0H3
- Government of Canada (2014) Canadian Environmental Assessment Act (2012) (S.C. 2012, c. 19, s. 52).
- Government of Newfoundland and Labrador (2003) Environmental Assessment Regulation, 2003, under the Environmental Protection Act (O.C. 2003-220).
- Government of Canada. 2015. Environment and Natural Resources: Air Quality: Air Quality Health Index: Newfoundland and Labrador: Grand Falls-Windsor. Accessed October 9, 2016. http://weather.gc.ca/airquality/pages/nlaq-003_e.html
- Government of Newfoundland and Labrador. 1997. Report on the Hydrology of Labrador.
- Government of Newfoundland and Labrador. Undated. Department of Tourism, Culture, Industry and Innovation - All Archaeological Sites of Newfoundland and Labrador. Accessed October 24, 2016. http://www.tcii.gov.nl.ca/pao/arch_sites/allsites.html
- Higgins, Jenny 2008 Newfoundland and Labrador Heritage Website, <http://www.heritage.nf.ca/articles/aboriginal/southern-inuit-land-claims.php>, Southern Inuit of NunatuKavut Organizations and Land Claims.
- HMM. 2014. Southern Labrador Waste Disposal Facility: Environmental Assessment Registration. Submitted to the Government of Newfoundland and Labrador Department of Environment September 2014.
- Innovation, Science and Economic Development Canada, Canadian Company Capabilities, Nunacor Development Corporation.
- Nunatsiavut Government. Undated. The Path to Self-Government. Accessed October 24, 2016. <http://www.nunatsiavut.com/government/the-path-to-self-government/>
- NunatuKavut (2010) Unveiling NunatuKavut: Describing the Lands and People of South/Central Labrador. Retrieved from http://www.nunatukavut.ca/home/files/pg/unveiling_nunatukavut.pdf on January 1, 2017.
- Pastore, Ralph. (1997). Aboriginal Peoples: The Beothuks: Newfoundland and Labrador Heritage. Retrieved November 10, 2016, from <http://www.heritage.nf.ca/aboriginal/beothuk.html>



Protected Areas Association of Newfoundland and Labrador (PAA). 2008. Mid Boreal Forest Ecoregion L7. Accessed December 10, 2016. Available online: <http://www.env.gov.nl.ca/env/parks/maps.html>

Roscoe, Postle Associates Inc. (RPA) (2016) Technical Report on the Foxtrot Project, Newfoundland and Labrador, Canada. Submitted to Search Minerals Inc.

SNC Lavalin (2016) Foxtrot REE Project Conceptual Study. Submitted to Search Minerals Inc.



Appendix A List of Potential Sara Species to the Project Site

Table A-1: List of Potential Species-at-Risk to the Project Site

Species Type	Scientific Name	Common Name	Status NL	COSEWIC Status	SARA Status ¹	Potential for Habitat within Proposed Project Site	Potential within 500 m Project Site
Mammal	<i>Martes americana atrata</i>	American Marten	THR	Threatened	Threatened	Yes	No
	<i>Myotis lucifugus</i>	Little Brown Myotis		Endangered	Endangered	Yes	Yes
	<i>Myotis septentrionalis</i>	Northern Myotis		Endangered	Endangered	Yes	Yes
	<i>Ursus maritimus</i>	Polar Bear	VUL	Special Concern	Special Concern	Potential unlikely due to Sites proximity from the shore	Potential unlikely due to proximity from the shore
	<i>Rangifer tarandus caribou</i>	Woodland Caribou	THR	Threatened	Threatened	No	No
Bird	<i>Bucephala islandica</i>	Barrow's Goldeneye	VUL	Special Concern	Special Concern	No	Yes
	<i>Numenius borealis</i>	Eskimo Curlew	END	Endangered	Endangered	No	No
	<i>Histrionicus histrionicus</i>	Harlequin Duck	VUL	Special Concern	Special Concern	No	Yes
	<i>Pagophila eburnea</i>	Ivory Gull	END	Endangered	Endangered	No	No
	<i>Catharus minimus minimus</i>	Newfoundland Gray-cheeked Thrush	THR	N/A	N/A	Yes	Yes
	<i>Calidris canutus rufa</i>	Red Knot	END	Endangered	Endangered	No	Yes
	<i>Euphagus carolinus</i>	Rusty Blackbird	VUL	Special Concern	Special Concern	Yes	Yes
	<i>Asio flammeus</i>	Short-eared Owl	VUL	Special Concern	Special Concern	No	No
Fish	<i>Anguilla rostrata</i>	American Eel	VUL	Threatened	No status	No	No

Source: Government of Canada, Species-at-Risk Public Registry, 2015; Department of Environment and Conservation, 2014

Note: NL (Newfoundland and Labrador); COSEWIC (Committee on the Status of Endangered Wildlife in Canada); SARA (Species-at-Risk Act Canada);

¹ This table only references Schedule 1 species within Newfoundland and Labrador that have habitat ranges within the Project Site and off-Site Study Area