



Appendix D.2

Fifteen Mile Stream Project Preliminary Waste and Water
Management Design for Submission of the Environmental Impact
Statement, Knight Piésold Ltd

Prepared for
Atlantic Mining NS Corp
409 Billybell Way, Mooseland
Middle Musquodoboit, Nova Scotia
Canada, B0N 1X0

Prepared by
Knight Piésold Ltd.
Suite 1400 - 750 West Pender Street
Vancouver, British Columbia
Canada, V6C 2T8

VA101-708/4-2

FIFTEEN MILE STREAM PROJECT

PRELIMINARY WASTE AND WATER MANAGEMENT DESIGN FOR SUBMISSION OF THE ENVIRONMENTAL IMPACT STATEMENT

Rev	Description	Date
0	Issued in Final for inclusion in the EIS Application	September 9, 2019
1	Issued with Revisions to Water Management Infrastructure	June 16, 2020

EXECUTIVE SUMMARY

Atlantic Mining NS Corp (AMNS) is proposing to develop the Fifteen Mile Stream Project (FMS Project), which is a proposed Open Pit gold mine located in Nova Scotia approximately 95 km northeast of the provincial capital of Halifax. The FMS Project is part of Phase II of the Moose River Consolidated (MRC) Project. The FMS Project is located approximately 57 km northeast of the central milling facility at Touquoy. The mine site is situated to the east of Highway 374 between Sheet Harbour and Trafalgar in Halifax County, Nova Scotia along Seloam Lake Road. The property can be accessed year-round via paved and gravel roads.

The project involves a conventional truck-shovel open pit mine and a 5,500 tonnes per day (tpd) processing plant. Ore will be processed on site at a nominal production rate of approximately 5,500 tpd to produce gold concentrate for shipment to Touquoy for final leaching. The mining and processing of ore will produce approximately 13.4 million tonnes (Mt) of tailings and 24.4 Mt of waste rock over a mine life of approximately seven years. The tailings will be conveyed to the Tailings Management Facility (TMF).

A Pre-Feasibility Study (PFS) was completed in 2018 on the Fifteen Mile Stream and Cochrane Hill deposits (the 2018 PFS). The selected TMF for the FMS Project for the 2018 PFS overlaps an area of potential mineralization (referred to as the 149-Zone), which is a target of on-going regional mineral exploration by AGC. The TMF arrangement was revised following the 2018 PFS to limit the potential for sterilization of mineral resources in the 149-Zone. The revised TMF arrangement and associated water management plan is the topic of this report.

The principle design objective of the TMF is to protect the environment during the operations and throughout the closure stage of the project and to achieve effective surface reclamation at mine closure. The design of the TMF has considered the following requirements:

- Permanent, secure, and total confinement of all tailings solids within an engineered facility
- Control, collection, and removal of free draining liquids from the tailings during operations, for recycling as process water to the maximum practical extent
- Inclusion of monitoring features for all aspects of the facility to verify that performance goals are achieved, and design criteria are met

The site of the TMF is located to the east and up-gradient of the proposed open pit and is situated in a position that limits impacts to wetlands and streams frequented by fish to the maximum practical extent. The TMF positioned in this manner allows the mine facilities to be clustered upstream of the open pit and simplifies surface water and groundwater management requirements for the mine site.

The TMF embankment will be constructed as a zoned earthfill-rockfill structure. The TMF will be developed in four stages over the mine life using downstream methods of construction. The maximum Stage One embankment height was estimated to be approximately 16 m. The embankment will include an upstream liner system with the liner extending from the upstream toe of the embankment into the TMF basin to control seepage gradients prior to the development of the tailings beaches. The embankment height will be raised over the life of the mine in three stages (of approximately four m each) to a maximum height of approximately 28 m at Stage Four.

The embankment will be constructed with a crest width of approximately 15 m to allow for single lane haul truck traffic within safety berms and pipeline routes. The embankment will be primarily constructed with pit

run waste rock. Filter and Transition Zones consisting of filter sand and drain gravel will be placed on the upstream face of the embankment. A liner material consisting of compacted, low-permeability till will be constructed on top of the filter zone material. Instrumentation will be installed in the TMF embankment and underlying foundation and monitored during all phases of the project. Monitoring data will be used to assess performance and to identify any conditions that differ from those assumed during design and analysis.

The TMF embankment has been assigned a dam classification of HIGH following Canadian Dam Association (CDA) guidelines. The dam classification is used to determine the minimum target levels for the Inflow Design Flood (IDF) and Earthquake Design Ground Motion (EDGM) for the TMF embankment. The following minimum target design flood and earthquake levels were adopted from the CDA guidelines (CDA, 2013 and 2014) for a HIGH dam hazard classification for the construction and operations phases of the project:

- IDF: 1/3 between the 1/1,000-year return period event and the Probable Maximum Flood (PMF)
- EDGM: the 1/2,475-year return period seismic event

Collection ditches along the perimeter road around the toe of the TMF embankment will collect runoff from the embankment and seepage through the embankment and foundation. The collection ditches will convey these flows to the two seepage collection ponds. Flows collected in the ponds (including precipitation on the surface of the pond) will be pumped back to the TMF supernatant pond.

Non-contact water will be diverted around site facilities to the maximum practicable extent to minimize the impact to local watercourses and the unnecessary collection of fresh water. Contact water from site facilities and stockpiles will be collected in a system of ditches that convey collected flows to water management ponds. Water collected in the water management ponds will be pumped to the TMF supernatant pond.

Seloam Brook will be diverted through the construction of a raised perimeter berm along the east, north and west of the Open Pit. The berm will divert flows from Seloam Brook around the open pit on the north side of the pit. The currently proposed berm alignment and crest elevation sufficiently realigns and diverts flows from a one-in-200 year, 24-hour precipitation event away from the mine working areas.

The Surplus Water Management System (SWMS) allows for the removal of excess water from the TMF supernatant pond during operations to maintain target operating pond volumes, tailings beach length, and minimum freeboard requirements. Surplus water will be removed by pumping water to a Water Treatment Plant (WTP) located near the Plant Site, if required to meet discharge criteria. Water will be discharged to Anti-Dam Flowage via a gravity discharge pipeline.

The water management plan forms the basis of the site wide water balance model, which has been developed on a monthly basis and considers a range of climatic conditions consistent with historic variability in the project area. The primary goal of the water balance model is to estimate the anticipated volume of surplus water that must be released from the mine site on an annual basis to manage the inventory of water stored in the TMF within a target range consistent with the design basis of the impoundment.

TABLE OF CONTENTS

	PAGE
Executive Summary	I
Table of Contents	i
1.0 Introduction	1
1.1 Project Description	1
1.2 Project History	2
1.3 Site Selection	2
1.4 Reference Reports	3
2.0 Site Characteristics	5
2.1 Site Drainage	5
2.2 Vegetation	5
2.3 Surficial Geology	5
2.4 Bedrock Geology	7
2.4.1 Regional Geology	7
2.4.2 Local Geology	7
2.5 Hydrometeorology	8
2.5.1 General	8
2.5.2 Temperature	8
2.5.3 Precipitation	9
2.5.4 Evaporation	9
2.5.5 Sublimation	10
2.5.6 Extreme Precipitation Events	10
2.5.7 Hydrology	11
2.6 Seismicity	12
2.6.1 Regional Tectonics and Seismicity	12
2.6.2 Seismic Hazard	12
3.0 Project Phases and Dam Classification	16
3.1 Project Phases	16
3.1.1 Mine Development Sequence	16
3.1.2 Phases in the Life of a Tailings Facility Dam	16
3.2 Dam Classification	18
3.2.1 Methodology	18
3.2.2 Fifteen Mile Stream Dam Classification	19
4.0 Tailings Management Facility Design	21
4.1 General	21
4.2 Design Basis	21
4.3 Embankment Staging and Filling Schedule	22

4.3.1	General	22
4.3.2	Embankment Construction	23
4.3.3	Foundation Preparation	26
4.4	TMF Embankment Spillway	26
4.5	Non-Contact Water Diversion Channels	26
4.6	Seloam Brook Diversion.....	26
4.7	Runoff Collection and Seepage Management	27
4.8	Tailings Distribution System.....	27
4.9	Reclaim Water System.....	27
4.10	Surplus Water Management System	28
4.11	Instrumentation and Monitoring	29
5.0	Water Management Plan and Mine Site Water Balance	30
5.1	General	30
5.2	Water Management Plan	30
5.2.1	Tailings Management Facility	30
5.2.2	Seepage Collection Ponds	31
5.2.3	Plant Site Water Management	32
5.2.4	Open Pit Water Management.....	32
5.2.5	Stockpile Water management	32
5.2.6	Non-Contact Water Diversion.....	33
5.3	Water Balance.....	33
5.3.1	Purpose	33
5.3.2	Methodology	33
5.3.3	Inputs.....	34
5.3.4	Assumptions	40
5.3.5	Water Balance Results	41
6.0	Construction.....	46
6.1	General	46
6.2	Site Establishment	46
6.3	Water Management.....	47
6.4	Water Management Monitoring.....	47
7.0	Operations and Monitoring	48
7.1	General	48
7.2	TMF Monitoring	48
8.0	Reclamation and Closure.....	50
8.1	Reclamation Objectives	50
8.2	Closure Water Management	52
8.3	On-going Monitoring Requirements	52
9.0	Summary.....	53
10.0	References.....	55

11.0 Certification 57

TABLES

Table 2.1	Estimated Long-Term Mean Monthly Air Temperatures.....	8
Table 2.2	Estimated Long-Term Mean Monthly Precipitation.....	9
Table 2.3	Estimated Long-Term Potential Evapotranspiration.....	10
Table 2.4	Estimated 24-Hour Extreme Precipitation Events.....	11
Table 2.5	Summary of Seismic Design Parameters.....	15
Table 3.1	Dam Classification (as per CDA, 2013).....	18
Table 3.2	Target Levels for Flood and Earthquake Hazards (CDA, 2014).....	19
Table 4.1	Design Basis and Operating Criteria.....	22
Table 5.1	Receiving Flow – Mean Conditions.....	35
Table 5.2	Surface Runoff Coefficients (Stantec, 2016).....	40
Table 5.3	TMF Annual Surplus - Operations.....	41
Table 5.4	Open Pit Annual Surplus – Post-Closure.....	45

FIGURES

Figure 1.1	Project Location.....	1
Figure 1.2	Project Area General Arrangement.....	4
Figure 2.1	Historical Seismicity of Nova Scotia and Surrounding Regions.....	14
Figure 3.1	Phases in the Life of a Tailings Management Facility (MAC, 2017).....	17
Figure 4.1	TMF Filling Schedule.....	23
Figure 4.2	TMF General Arrangement.....	24
Figure 4.3	TMF Embankment Cross-Section.....	25
Figure 4.4	Surplus Water Management System – Plan.....	28
Figure 5.1	TMF Stage Storage Curve.....	31
Figure 5.2	Receiving Flow – Mean Conditions.....	36
Figure 5.3	Contributing Catchment Areas.....	37
Figure 5.4	Water Balance Flow Schematic – Operations (Year -1 to 7).....	38
Figure 5.5	Water Balance Flow Schematic – Closure and Post-Closure (Year 8 and onwards).....	39
Figure 5.6	TMF Annual Surplus - Operations.....	42
Figure 5.7	Open Pit Volume – Closure and Post-Closure.....	43
Figure 5.8	Open Pit Monthly Discharge Rates and Receiving Flow Under Average Climate Conditions	44
Figure 5.9	Open Pit Annual Surplus – Post-Closure.....	45
Figure 8.1	Reclaimed TMF General Arrangement.....	51

APPENDICES

- Appendix A Design Figures
- Appendix B Design Basis and Operating Criteria
- Appendix C Updated Seismic Design Parameters (KP, 2019)
- Appendix D Water Balance Inputs, Assumptions and Results
 - Appendix D1 Climate Inputs
 - Appendix D2 Water Balance Inputs
 - Appendix D3 Operational Water Balance Results
 - Appendix D4 Closure Water Balance Results
- Appendix E Fifteen Mile Stream Terrain and Landform Mapping (KP, 2018)

ABBREVIATIONS

AEP	annual exceedance probability
AMNS	Atlantic Mining NS Corp
ARD	acid rock drainage
CDA	Canadian Dam Association
ECCC	Environment and Climate Change Canada
EDF	environmental design flood
EDGM	earthquake design ground motion
EIS	environmental impact statement
EPRP	emergency preparedness and response plan
FFSI	FFSI Consultants Ltd.
FMS	Fifteen Mile Stream Project
IDF	inflow design flood
KP	Knight Piésold Ltd.
L/sec	litres per second
MAC	Mining Association of Canada
MAP	mean annual precipitation
MAUD	mean annual unit discharge
MRC	Moose River Consolidated Project
MMTS	Moose Mountain Technical Services
NBCC	National Building Code of Canada
Non-PAG	non-potentially acid generating
NRCAN	Natural Resources Canada
NRCC	National Research Council of Canada
NSDNR	Nova Scotia Department of Natural Resources
OMS Manual	Operations, Maintenance and Surveillance Manual
OSCP	Ore Stockpile Collection Pond
PAG	potentially acid generating
PFS	Prefeasibility Study
PGA	peak ground acceleration
PSCP	Plant Site Collection Pond
RFA	rainfall frequency atlas
SCP	seepage collection pond
TMF	Tailings Management Facility
tpd	tonnes per day
TTSCP	Till and Topsoil Stockpile Collection Pond
t/m ³	tonnes per cubic metre
WRSCP	Waste Rock Stockpile Collection Pond
WSC	Water Service of Canada

1.0 INTRODUCTION

1.1 PROJECT DESCRIPTION

Atlantic Mining NS Corp (AMNS) is proposing to develop the Fifteen Mile Stream Project (FMS Project), which is a proposed Open Pit gold mine located in Nova Scotia approximately 95 km northeast of the provincial capital of Halifax. The FMS Project is part of Phase II of the Moose River Consolidated (MRC) Project. The MRC Project consists of the following four mining properties as shown on Figure 1.1:

- MRC Phase I, consisting of the Touquoy Mine commissioned in 2017 and the planned Beaver Dam Mine
- MRC Phase II Expansion, which includes the Fifteen Mile Stream and Cochrane Hill Projects

The Fifteen Mile Stream and Cochrane Hill Projects were evaluated as standalone mines with their own plants and site infrastructure. The concentrate from each site will be shipped to and processed at the Touquoy Mine leaching facility.

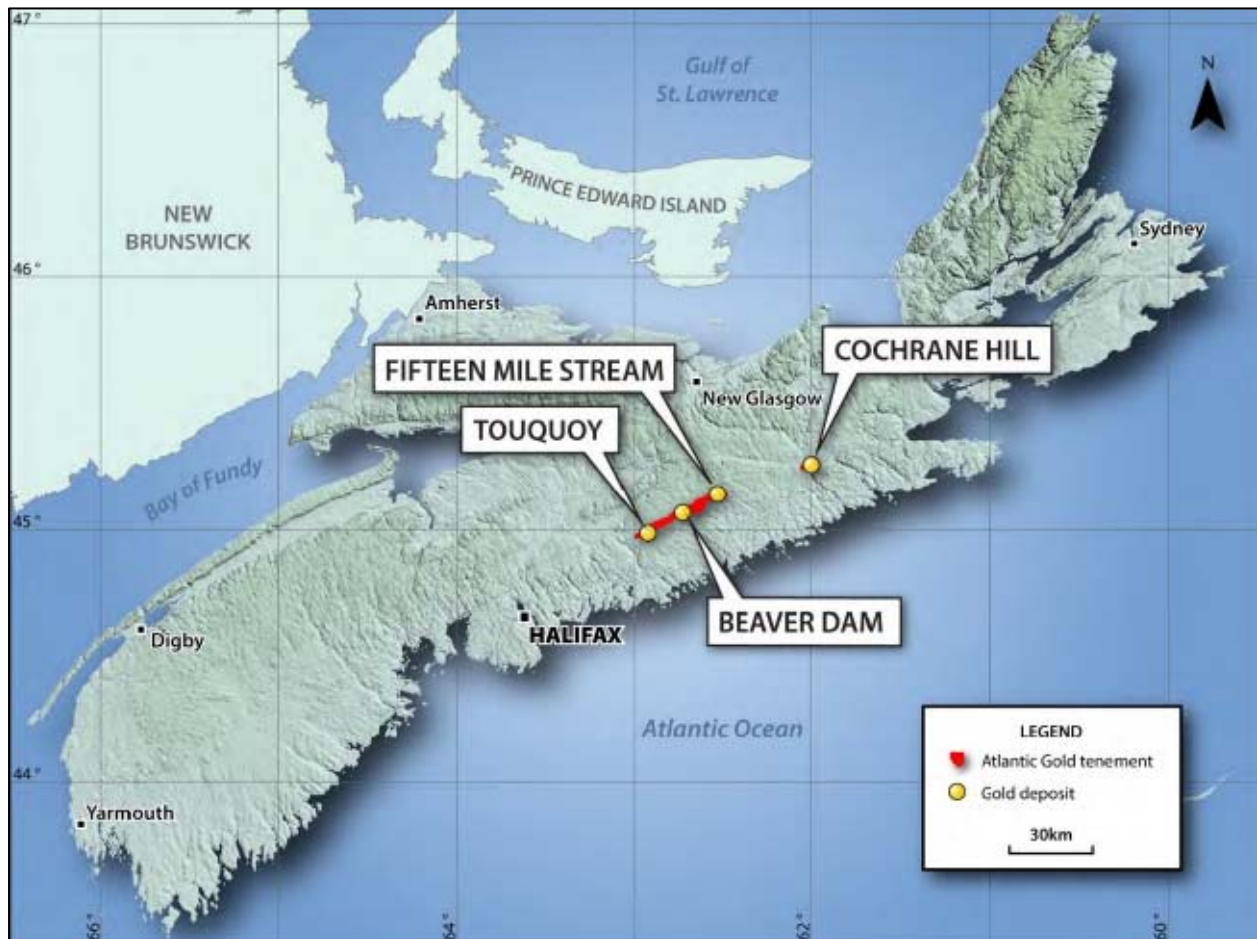

NOTES:

1. COPIED FROM FIGURE 2-1 OF THE NI 43-101 TECHNICAL REPORT (STAPLES, P. ET AL., 2018).

Figure 1.1 Project Location

The FMS Project is gold deposit located approximately 95 km northeast of Halifax and 57 km northeast of the central milling facility at Touquoy. The mine site is situated to the east of Highway 374 between Sheet Harbour and Trafalgar in Halifax County, Nova Scotia along Seloam Lake Road. The property can be accessed year-round via paved and gravel roads. The closest international airport is the Halifax Stanfield International Airport (Halifax Airport) located approximately 25 km north of Halifax. The closest major port is the Port of Halifax. The climatic conditions for the project area are representative of the Northern temperate zone, and mining operations are expected to be conducted year-round.

The site is approximately 20 km south of the Trafalgar power station and will be connected to the power grid by a one km overhead power line connected to the 69 kV line that runs adjacent to the planned mine site. A step-down transformer to 25 kV will be constructed to service the mine requirements. A site access road will be constructed to link the site facilities to Highway 374. Transport of concentrate from the FMS Project to the Touquoy Mine will be along public roads.

The project involves a conventional truck-shovel open pit mine and 5,500 tonnes per day (TPD) processing plant. The processing plant includes three stages of crushing followed by grinding in a ball mill in a closed circuit with hydrocyclones. Centrifugal gravity separation units will be installed to recover gravity recoverable gold. Centrifugal gravity separation units will be installed to recover gravity recoverable gold. The primary cyclone overflow will report to conventional flotation to recover both free and sulphide gold. Gold concentrate will be thickened and pressure-filtered before being transported by truck to the process plant at the Touquoy Mine Site. The final tailings from both circuits will be conveyed to the Tailings Management Facility (TMF).

1.2 PROJECT HISTORY

The FMS Project site is part of the historic Fifteen Mile Stream Gold District. Gold was discovered in the project area in 1867. Early mining activity by various individuals and groups occurred between 1874 and 1938 with local stamp milling and tailings discharged in the vicinity of nearby surface water bodies. Accumulations of tailings are still present in and around Seloam Brook in the deposit area from this early small-scale mining. Many trenches and shafts related to previous mining occur on the property. The provincial government took ownership of the district between 1938 and 1941, and from then until 1980 there appears to have been very little exploration or mining in the area. The property was investigated using a variety of methods by several mineral exploration companies beginning in 1980 before AGC acquired the property in 2014 through acquisition of Acadian Mining Corporation. AGC now controls all of the claims over the historic gold district (FSSI, 2015).

1.3 SITE SELECTION

Knight Piésold Ltd. (KP) became involved with the FMS Project in August 2017. KP performed a desktop study and identified several potential tailings facility options to guide AGC's definition of initial boundaries for environmental fieldwork (KP, 2017).

A PFS was completed in 2018 for the entire Moose River Consolidated Project (the 2018 PFS). Information from the 2018 PFS was combined with information from prior studies and released in a National Instruments (NI) 43-101 compliant technical report (Staples, P. et al., 2018). The selected TMF option for the FMS Project in the 2018 PFS overlaps an area of potential mineralization (referred to as the 149-Zone), which is a target of on-going regional mineral exploration by AGC. The TMF arrangement was revised following the

2018 PFS to limit the potential for sterilization of mineral resources in the 149-Zone. The revised TMF arrangement and associated water management plan is the topic of this report.

The site of the TMF is located to the east and up-gradient of the proposed open pit and is situated in a position that limits impacts to wetlands and streams frequented by fish to the maximum practical extent. The TMF positioned in this manner allows the mine facilities to be clustered upstream of the open pit and simplifies surface water and groundwater management requirements for the mine site. This report summarizes the preliminary design of the TMF, and infrastructure related to water management for the FMS Project in support of the submission of the Environmental Impact Statement (EIS). An overview of the project area general arrangement is shown on Figure 1.2. A package of design figures was developed to facilitate preparation of the EIS and is included in this report as Appendix A.

1.4 REFERENCE REPORTS

The following KP subject matter reports were prepared as standalone documents and provide additional details relevant to the design of the FMS Project:



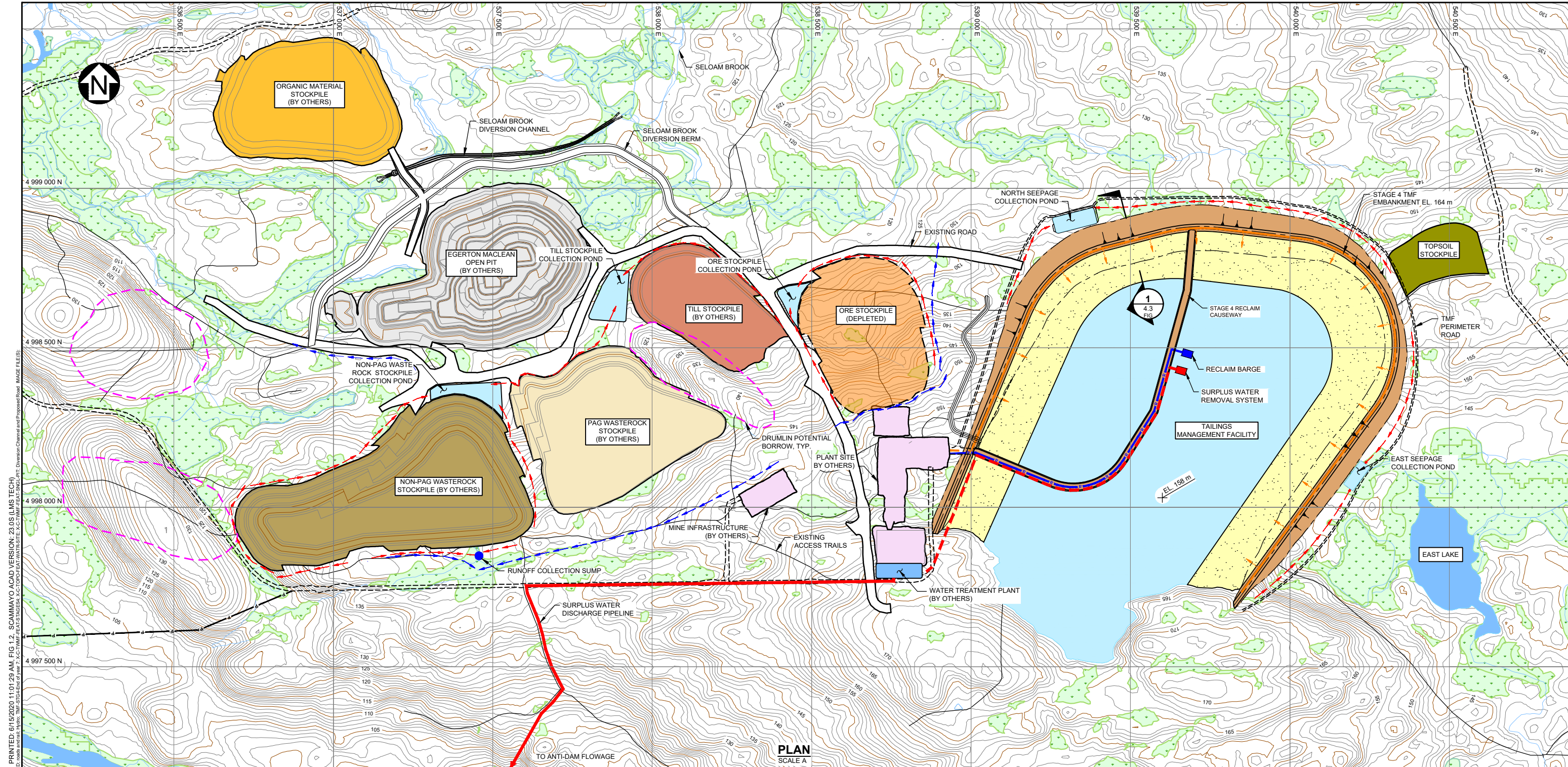







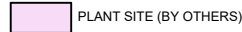



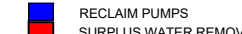



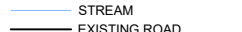

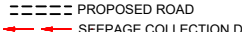

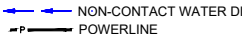

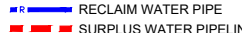
- Fifteen Mile Stream Project – TSF Options Development (KP, 2017)
- Fifteen Mile Stream – Desktop Terrain Analysis Study (KP, 2018a)
- Moose River Consolidated Phase II – Preliminary Engineering Hydrometeorology Report (KP, 2018b)
- Moose River Consolidated Phase II – Updated Seismic Design Parameters (KP, 2019)

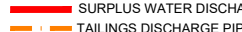

FILED: M:\1\100708\04\Acad\FIGS\16_6\12\2020 11:01:29 AM FIG 1.2_SCAMMAYO ACAD VERSION: 23.015 (LMS TECH)
 THE FILES AND CONTENTS HEREIN ARE UNCLASSIFIED AND UNCONTROLLED. ANY CHANGES TO THESE FILES AND CONTENTS SHOULD BE MADE TO THE ORIGINAL FILES AND CONTENTS. THIS DRAWING IS A PRELIMINARY DESIGN AND SHOULD NOT BE USED FOR CONSTRUCTION OR AS A BASIS FOR CONTRACTS. THE INFORMATION HEREIN IS FOR INFORMATION ONLY.

PLAN
SCALE A

LEGEND:

 MINE WATER	 PLANT SITE (BY OTHERS)
 FRESH WATER	 TOPSOIL PILE (BY OTHERS)
 TAILINGS	 RECLAIM PUMPS
 EMBANKMENT FILL	 SURPLUS WATER REMOVAL SYSTEM
 WETLAND	 WATER MANAGEMENT POND
 OPEN PIT (BY OTHERS)	 STREAM
 ORE STOCKPILE (DEPLETED)	 EXISTING ROAD
 PAG STOCKPILE (BY OTHERS)	 PROPOSED ROAD
 NON-PAG STOCKPILE (BY OTHERS)	 SEEPAGE COLLECTION DITCH
 TILL STOCKPILE (BY OTHERS)	 NON-CONTACT WATER DITCH
 ORGANIC MATERIAL STOCKPILE (BY OTHERS)	 POWERLINE
	 RECLAIM WATER PIPE
	 SURPLUS WATER PIPELINE
	 SURPLUS WATER DISCHARGE PIPELINE
	TAILINGS DISCHARGE PIPE
	TAILINGS DEPOSIT

NOTES:

1. COORDINATE GRID IS NAD83, ZONE 20 T.
2. CONTOURS BASED ON 2014 LIDAR OBTAINED FROM GEONOVA, REPRODUCED AND DISTRIBUTED WITH THE PERMISSION OF INTERNAL SERVICES. CONTOURS HAVE BEEN PRODUCED BY KNIGHT PIESOLD LTD. AND INCLUDES DATA PROVIDED BY INTERNAL SERVICES. THE INCORPORATION OF DATA SOURCED FROM INTERNAL SERVICES WITHIN THIS PRODUCT SHALL NOT BE CONSTRUED AS CONSTITUTING AN ENDORSEMENT BY INTERNAL SERVICES OF OUR PRODUCT.
3. WETLAND AND WATER COURSE MAPPING PROVIDED BY McCALLUM ENVIRONMENTAL LTD. SEPTEMBER 06, 2018. DATA PROVIDED IN DRAFT WITH NO IMPLIED WARRANTIES AND SHALL BE CONSIDERED PRELIMINARY.
4. DIMENSIONS AND ELEVATIONS ARE IN METRES, UNLESS NOTED OTHERWISE.

FOR INFORMATION ONLY



REV	DATE	DESCRIPTION	DESIGNED	DRAWN	REVIEWED
1	12JUN20	ISSUED WITH REPORT	JEF	RMM/SC	DDF

ATLANTIC MINING NS CORP.	
FIFTEEN MILE STREAM PROJECT	
PROJECT AREA GENERAL ARRANGEMENT	
	P/A NO. VA101-708/4 REF NO. 2 FIGURE 1.2 REV 1

2.0 SITE CHARACTERISTICS

2.1 SITE DRAINAGE

The project site is situated to the east of Highway 374 and the Fifteen Mile Stream watercourse, which runs approximately parallel to Highway 374 in the study area. Seloam Lake is a man-made reservoir (sometimes called Sloane Reservoir) that bounds the northern margin of the study area. Seloam Lake is drained by Seloam Brook, which runs through the project area and drains west to its confluence with Fifteen Mile Stream. Seventeen Mile Stream combines with Fifteen Mile Stream several kilometers upstream of the confluence with Seloam Brook. Fifteen Mile Stream is a tributary of the East River and forms a component of the provincial hydroelectric system in Nova Scotia, specifically the East River Sheet Harbour Hydro System. Fifteen Mile Stream is regulated by the flow control structure at the Anti Dam Flowage (sometimes called Anti Dam Reservoir) located to the south of the project site. The mine facilities are located entirely within the drainage area of the Anti Dam Flowage and are confined by natural topography to the west.

2.2 VEGETATION

The FMS Project is located in the Governor Lake Ecodistrict (450) in the centre of the eastern mainland. On the upper slopes of the region exists hardwood forests consisting of maple, beech, and yellow birch. Elsewhere in the ecodistrict softwood forests dominate the landscape that consist of red spruce, and scattered hemlock. Isolated pockets of white pine are found along shallow soils rides in combination with black spruce (Nova Scotia Department of Natural Resources (NSDNR), 2005).

The FMS Project area shows evidence of historical forestry and logging operations, which is evidenced through clear cutting activities noted through aerial photogrammetry.

2.3 SURFICIAL GEOLOGY

The dominant landscape in the area is characterized by undulating to rolling topography, wetlands, and woodland dissected by lakes and streams. Approximately 6% of the ecodistrict is covered by lakes and streams (NSDNR, 2005). Provincial (1:500,000 scale) surficial geology maps for the region are publicly available from the Province of Nova Scotia Department of Natural Resources. The surficial geology map (Stea, 1992) details the distribution and nature of the Quaternary glacial deposits in Nova Scotia, as well as providing a summary of the major ice flow phases of the Wisconsinan glacial stage.

A terrain analysis comprised of geomorphic interpretation of a Bare Earth Digital Elevation Model (Bare Earth DEM) was performed to develop a preliminary understanding of the site geologic model (KP, 2018a). The study area is bounded on the western margin by the Fifteen Mile Stream watercourse and Highway 374. The northern margin of the study area runs from Highway 374 across to the north end of Seloam Lake. The eastern margin extends to Moser Lake and Grassy Lake. The southern margin extends from Grassy Lake westward to Highway 374. The study is included in Appendix E, and the findings are summarized below.

The physiography, landforms and surficial deposits of the area are associated with the Late Wisconsinan Glaciation, which occurred between approximately 10,000 and 25,000 years before present. During this glacial period, four distinct ice flow phases are identified as having occurred in the region, with the early and late phase glacial periods contributing significantly to the glacial landforms and deposits currently

identified in the project area. Topography at the site ranges from between 110 m and 150 meters above sea level (masl). Scattered drumlin features reach approximately 170 masl. The following landforms were identified in the terrain analysis:

- Glacial flutings
- Kame mounds
- Kettle holes
- Drumlins
- Glaciofluvial Outwash Plains
- Alluvial Floodplains

Drumlins, and drumlinoid ridges, are typically smooth, oval-shaped, or elliptical glacial landforms that are indicative of the presence of lodgement till. Drumlins were identified within the study area trending predominantly in a northwest to southeast direction. These landforms likely developed as the ice sheet advanced during the first phases of the Wisconsinan Glaciation.

Glacial flutings are low, linear ridges of lodgement till that formed beneath moving ice sheets during the last glaciation. Lodgement till is dense, or stiff, and contains significant interstitial silt that greatly lowers its permeability. The flutings are oriented predominantly in a west-southwest to east-northeast direction in the south part of the study area indicating that they were deposited during the Phase four ice flow of the Late Wisconsinan glaciation. The distribution of flutings suggests lodgement till is widespread across the southern part of the study area. Some flutings were also mapped in the northern section of the study area.

The generally hummocky nature of the topography indicates ablation till to be more widespread than lodgement till. Ice-contact glaciofluvial deposits occur as kames and kame complexes throughout the study area with the exception of the north, south and west margins. Kames were identified throughout the study area on the Bare Earth DEM along with some kettle holes. These features typically comprise laterally discontinuous mounds of gravel and sand with trace to some silt. They formed where streams deposited coarse sediment in cavities in the ice sheet. The kames commonly occur in groups, referred to as kame complexes. The kame deposits are interpreted to be relatively thin (in the order of several metres thick). Kettles are closed depressions that occur locally within the kame complexes. They formed when detached blocks of ice melted at the end of the last glaciation. Their floors are commonly below the water table; thus, kettles are commonly occupied by ponds or lakes.

A broad outwash plain in the southwest part of the study area is evidence of glaciofluvial deposits from the receding ice sheet. A smaller outwash plain was identified in the northwestern part of the study area. The outwash plains are oriented in a north-northwest to south-southeast direction. The outwash plains are interpreted to comprise sands and gravels. Meltwater scarps were identified locally. These features were formed by sub-glacial streams that eroded the ground on one bank but were bounded by ice on the other. Local sand and gravel deposits may accompany these features. Alluvial floodplains occur adjacent to the current watercourses.

2.4 BEDROCK GEOLOGY

2.4.1 REGIONAL GEOLOGY

The intruding Meguma Group, a folded succession of Cambrian-Ordovician aged metasedimentary rocks, underlies the FMS Project area. The Meguma group sedimentary package is divided into two distinct formations; the Goldenville Formation and the younger Halifax Formation, both of which have been subjected to regional metamorphism to greenschist and amphibolite grade (FSSI, 2015). The Goldenville Formation consists of metagreywacke and interbedded slate while the Halifax Formation consists of thinly laminated slate with small amounts of interbedded metasiltstone and metagreywacke. The boundary between these two formations is conformable and can be sharp or gradational (Schenk, 1970; Brooks et al., 1982). Gold in Nova Scotia is found associated with groups of quartz veins that are concordant to the stratigraphy in the Meguma Group. These veins are thought to result from early metamorphism and deformation (Graves and Zentilli, 1982).

The principal rock types in the formation are metamorphosed high-grade schists and gneisses (DNR, 2005). The majority of the Meguma gold deposits are constrained to within the Goldenville Formation and typically associated with regional anticlinal folds close to later northwest trending transcurrent faults. The Goldenville Formation hosts numerous gold deposits throughout the Meguma Terrane that are classified as ‘saddle-reef’ style deposits during the late fold tightening related to the Acadian Orogeny (FSSI, 2015).

2.4.2 LOCAL GEOLOGY

The gold deposits of the Fifteen Mile Stream (FMS) gold district are contained within the rocks of the Goldenville Formation. The district is located along the Waverley-Fifteen Mile Stream anticline which continues towards Moose River, at which point it unites with the Beaver Dam anticline to form the Moose River-Beaver Dam anticline.

The major anticline at FMS is composed of three minor folds. The two most northerly folds are separated by only 40 metres and plunge to the east at 30 degrees. The northernmost anticline is exposed in the west end of the district along the eastern bank of FMS. The plunge of the anticline to the west is at an average of 18 degrees. The east and west plunges of the major anticline meet and form a dome west of the Hudson Deposit.

Faults in the area run parallel or nearly parallel to the strike of the strata. The quartz veins are of the interbedded class and lie within slate beds with metagreywacke walls. The distribution of the veins is related to the rock structure. The veins are usually found at the domes and on the limbs of anticlines (Faribault, 1913). On the sharp, closely folded anticlines the veins are found close to the apex of the fold and generally curve over the anticline. Corrugated veins are common in this district and are usually found near the apex of an anticline. These veins are usually parallel to one another and strike in a direction approximately parallel to the axis of the fold. Where the corrugations become enlarged over a significant distance, they are called rolls. These rolls are favourable locations for gold mineralization. The major portion of the gold at Fifteen Mile Stream was mined from these rolls. The rocks of this study area possess no effects of contact metamorphism. The nearest granites are five km to the north, 10 km south, and 13 km west. There is no evidence of granites underlying the country rocks in the study area (McNulty, 1983).

2.5 HYDROMETEOROLOGY

2.5.1 GENERAL

A regional climate study was conducted using data available from Environment and Climate Change Canada (ECCC) in the absence of site-specific climate monitoring data. Temperature and precipitation data were compared between six regional stations operated by ECCC, which have a period of record of at least 30 years and a maximum distance from the project of 50 km, in order to determine estimated values most appropriate for the FMS Project area. Halifax Airport station data was selected to reasonably represent actual conditions in the FMS Project area after analysis of data from these regional stations. Halifax Airport was selected due to its similar distance to the coast (approximately 30 km) and similar elevation to the project area.

There are several hydrometric stations operated by Water Survey of Canada (WSC) in the region. The majority of stations have been deactivated for a prolonged period of time or are located sufficiently far from the FMS Project area such that the hydrological conditions are expected to be different from conditions at the FMS Project site. The data from three WSC stations with a period of record of at least 30 years and a maximum distance from the project area of 50 km. The St. Mary's River at Stillwater Station (01EO0001) was selected as the station representative of the hydrologic conditions for the FMS Project area. The St. Mary's River station has the longest period of record and is currently an active station.

Key climate and hydrometric data are summarized below. Additional details on the analyses described above are included in a separate report (KP, 2018b). Other climate parameters such as wind speed, relative humidity, and atmospheric pressure are available for the Halifax Airport station and are summarized in the referenced report.

2.5.2 TEMPERATURE

The mean annual temperature for the FMS Project area is estimated to be 6.5°C, with minimum and maximum mean monthly temperatures of -5.8°C and 18.7°C occurring in January and July, respectively. The mean monthly, maximum monthly mean, and minimum monthly mean temperatures for the project area based on Halifax Airport based on the full period of record from 1953 to 2018 are presented in Table 2.1.

Table 2.1 Estimated Long-Term Mean Monthly Air Temperatures

Station Name	Value	Temperature (°C)												
		Jan	Feb	Mar	Apr	May	Jun	Jul	Aug	Sep	Oct	Nov	Dec	Annual
Halifax Airport	Max Monthly Mean	-1.5	-1.1	2.6	7.3	13.0	17.4	21.0	20.7	18.5	12.4	6.0	1.5	21.0
	Mean Monthly	-5.8	-5.6	-1.5	3.9	9.8	14.9	18.7	18.6	14.5	8.9	3.5	-2.4	6.5
	Min Monthly Mean	-10.3	-10.0	-5.0	0.7	6.5	13.2	15.3	16.2	11.8	5.6	1.0	-9.6	-10.3

NOTES:

1. THE MEAN MONTHLY VALUE REPRESENTS THE MEAN TEMPERATURE FOR A GIVEN MONTH FOR THE ENTIRE PERIOD OF RECORD.
2. THE MIN AND MAX MONTHLY MEAN REPRESENTS THE MINIMUM AND MAXIMUM VALUE OF THE MEAN TEMPERATURE IN A SINGLE MONTH WITHIN THE PERIOD OF RECORD.

2.5.3 PRECIPITATION

The mean annual precipitation (MAP) estimate for the project area is estimated to be 1,440 mm with mean monthly values ranging from a low of 93 mm in July to a high of 164 mm in December, as shown in Table 2.2. Precipitation is reported by ECCC as rain or snow for the stations of interest. The majority of precipitation falls as rain even in the winter months, which is expected for a moderate coastal region such as Nova Scotia. Based on the Halifax Airport station, 83% of the precipitation falls as rain and the remaining 17% falls as snow annually. Mean monthly rain and snow distributions are provided in the report (KP, 2018b).

Table 2.2 Estimated Long-Term Mean Monthly Precipitation

Station Name	Value	Precipitation (mm)												
		Jan	Feb	Mar	Apr	May	Jun	Jul	Aug	Sep	Oct	Nov	Dec	Annual
Halifax Airport	Max Monthly Mean	313	210	263	228	319	307	190	387	309	335	268	295	1,931
	Mean Monthly	138	118	122	113	108	97	93	99	103	134	150	164	1,440
	Min Monthly Mean	21	30	19	30	26	18	8	17	18	28	37	44	1,048

NOTES:

1. THE MEAN MONTHLY VALUE REPRESENTS THE MEAN PRECIPITATION FOR A GIVEN MONTH FOR THE ENTIRE PERIOD OF RECORD.
2. THE MIN AND MAX MONTHLY MEAN REPRESENTS THE MINIMUM AND MAXIMUM VALUE OF THE MEAN PRECIPITATION IN A SINGLE MONTH WITHIN THE PERIOD OF RECORD.

2.5.4 EVAPORATION

Monthly Potential Evapotranspiration (PET) data were estimated using the Thornthwaite equation (Thornthwaite and Mather, 1955). PET is defined as the amount of evapotranspiration that would occur given an infinite supply of water from a crop surface, and these values are believed to be reasonably representative of lake evaporation conditions (Ponce, 1989; Maidment, 1993). The benefit of the Thornthwaite equation over other methods is that the equation only requires inputs of temperature and of the daylight factor, which depends on the month and latitude. A limiting factor of the Thornthwaite equation is that 12 months of data in a year are always required; otherwise the respective year must be ignored.

Temperature data from the Halifax Airport station were used as inputs to the Thornthwaite equation. Resultant monthly and annual estimates of PET are summarized in Table 2.3. The estimated long-term annual PET value for the FMS Project is 564 mm, with little to no evapotranspiration occurring during winter months. This estimate is supported by the 4th Edition (1974) of the Atlas of Canada Potential Evapotranspiration map, which estimates PET as approximately 550 mm. Actual evapotranspiration (AET) is typically in the order of 60% to 80% of PET, and therefore AET is estimated to be between 340 mm to 450 mm.

Table 2.3 Estimated Long-Term Potential Evapotranspiration

Station Name	Unit	Evapotranspiration (mm)												
		Jan	Feb	Mar	Apr	May	Jun	Jul	Aug	Sep	Oct	Nov	Dec	Annual
Halifax Airport	mm	0	0	0	23	64	99	126	116	78	43	14	0	564
	% annual	0%	0%	0%	4%	11%	18%	22%	21%	14%	8%	3%	0%	100%

NOTES:

1. THE LONG-TERM PET VALUES ARE BASED ON THE LONG-TERM MEAN MONTHLY TEMPERATURE VALUES AT THE HALIFAX AIRPORT STATION USING THE THORNTHWAITE EQUATION.
2. THE THORNTHWAITE EQUATION ASSUMES THAT WHEN THE MEAN MONTHLY TEMPERATURE IS EQUAL TO OR LESS THAN ZERO, PET IS ZERO.

2.5.5 SUBLIMATION

Sublimation is the process by which moisture is returned to the atmosphere directly from snow and ice without passing through the liquid phase (Liston and Sturm, 2004). Sublimation can play a significant role in the annual hydrologic water balance in areas where winter precipitation comprises a large proportion of annual precipitation. Many estimates and methods of estimating sublimation found in the literature, are site-specific, subject to significant uncertainty, and not easily extrapolated. Sublimation may be considered negligible compared to the daily melt rates in the project area considering that a long-term snowpack typically does not occur in the region.

2.5.6 EXTREME PRECIPITATION EVENTS

Estimates of extreme precipitation are required for many aspects of design. The most common and useful information is the 24-hour extreme precipitation, given for different return periods, as well as for the probable maximum precipitation (PMP). Two sets of estimates were made for the FMS Project area following the frequency factor approach as presented in the Rainfall Frequency Atlas (RFA) for Canada (Hogg and Carr, 1985). Mean and standard deviations for the project area were derived directly from the RFA as well as from the measured Halifax Airport precipitation record. The larger return period values were selected as appropriately conservative and the values generated using the measured record at the Halifax Airport station are recommended to be used for the design of various structures in the project area. The estimated 24-hour extreme precipitation values for various return periods are summarized in Table 2.4.

Table 2.4 Estimated 24-Hour Extreme Precipitation Events

Return Period (years)	24-Hour Extreme Precipitation (mm)
2	75
5	100
10	116
15	126
20	132
25	137
50	153
100	168
200	184
500	204
1,000	219
PMP	531

2.5.7 HYDROLOGY

Regional runoff patterns are characterized by moderate flows during winter months from November to March, an increase in flows during the spring freshet season in April and May, and lower flows in the summer months from July to September. June and October are transitional shoulder months between higher and lower flow periods. Sustained flows in response to storm systems can be observed throughout the year. Hydrology estimates applicable to the FMS Project area are as follows:

- The long-term mean annual unit discharge (MAUD) for the project area was estimated to be 31.8 L/s/km², which equates to an annual runoff depth of approximately 1,000 mm.
- The effective annual runoff coefficient for natural drainage areas was estimated to be 0.70 based on the ratio of mean annual runoff to mean annual precipitation. This estimate should be refined seasonally following site-specific data collection and analysis.
- A mean annual unit runoff (MAUR) of approximately 1,000 mm is generally consistent with the estimates of precipitation (1,440 mm) and AET (340 mm to 450 mm).
- The annual hydrograph is bimodal with the lowest flows occurring in the late summer and winter, and the peak flows occurring during the spring freshet and during the fall storm season.
- The 10-year wet and dry annual unit discharges were estimated to be 54.8 L/s/km² and 13.5 L/s/km², respectively.
- The 10-year seven-day low unit discharge was estimated to be 0.5 L/s/km².
- Peak freshet flows in the spring are due to snowmelt, or combined rainfall and snowmelt events, and peak flows in the fall are due to cyclonic storm events affecting the eastern seaboard. The 100 and 200-year return period instantaneous peak unit discharge were estimated to be 824 L/s/km² and 924 L/s/km², respectively.
- It is recommended that peak design flows are increased by 15% for structures with a design life longer than 30 years.

2.6 SEISMICITY

2.6.1 REGIONAL TECTONICS AND SEISMICITY

A review of regional seismicity was carried out to enable selection of appropriate design earthquake events and corresponding design ground motions (KP, 2018d). Eastern Canada is located in a stable continental region within the North American tectonic plate and has a relatively low rate of seismic activity. However, moderate to large earthquakes have occurred in the region and can be expected in the future. In eastern Canada, earthquakes are believed to be primarily caused by a northeast-to-east oriented compressive stress field reactivating zones of crustal weakness – either failed rifts or old fault zones (Cassidy et al., 2010). Historical seismic data recorded throughout eastern Canada has identified clusters of earthquake activity. Historical seismicity of Nova Scotia and surrounding regions is shown on Figure 2.1.

A Magnitude (M) 5.4 earthquake occurred in 1982 in the north-central Miramichi Highlands, New Brunswick, within the Northern Appalachians seismic zone (Adams and Halchuk, 2003; Halchuk et al., 2015). The main shock was followed by numerous strong aftershocks. A Magnitude 7.2 earthquake occurred offshore in 1929 near the Atlantic margin at about 250 km south of Newfoundland along the southern edge of the Grand Banks within the Laurentian Slope seismic zone (Adams and Halchuk, 2003; Halchuk et al., 2015). This earthquake was felt as far away as New York and Ottawa and triggered a large tsunami (seismic sea-wave) caused by a large submarine slump (estimated at 200 km³ of material). The tsunami caused flooding and loss of life when it came ashore on the Burin Peninsula in southern Newfoundland (Cassidy et al., 2010). The project site is located approximately 400 km away from the 1982 M5.4 earthquake and more than 500 km away from the 1929 M7.2 earthquake. The historical seismic activity near the project site is low.

The Charlevoix seismic zone, which is the most seismically active region of eastern Canada, is located about 100 km downstream from Quebec City. Most earthquakes in this zone occurred under the St. Lawrence River between Charlevoix County on the north shore and Kamouraska County on the south shore with five large earthquakes (M 5.9 to 7.0) occurring since 1663. The most recent large earthquake in this seismic zone occurred in 1925 (M 6.2) and the largest occurred in 1663 (M 7.0). The project site is located more than 600 km away from the Charlevoix seismic zone. The seismic hazard at the project site due to future earthquakes in this zone would be very low due to attenuation over such a large distance.

2.6.2 SEISMIC HAZARD

Site-specific seismic ground motion parameters were determined for the FMS Project area using the probabilistic seismic hazard database of Natural Resources Canada (NRCAN). The results are summarized in Table 2.5 in terms of earthquake return period, Annual Exceedance Probability (AEP), and the corresponding horizontal Peak Ground Acceleration (PGA) for earthquake events having return periods of 100 years, 475 years, 1,000 years, and 2,475 years.

A site-specific probabilistic seismic hazard model was developed using the EZ-FRISK program to provide PGA and spectral accelerations for longer return periods of 5,000 years and 10,000 years (KP, 2018d). Calculated values for these longer return periods are included in Table 2.5. The calculated values for return periods up to 2,475 years were in excellent agreement with the values provided by NRCAN. An earthquake Magnitude of 7.25 is recommended for seismic design studies for return periods ranging from 475 years to 10,000 years, based on a de-aggregation analysis of the probabilistic seismic hazard results provided by

the EZ-FRISK model. Additional discussion and spectral accelerations (5% damping) are provided in Appendix C.

The acceleration values in Table 2.5 correspond to a reference ground conditions of Site Class C with an average shear wave velocity V_{s30} of 450 m/s (defined by the National Building Code of Canada (NBCC) as very dense soils or soft rock (National Research Council of Canada, 2015)). Appropriate factors will need to be applied to these values to account for seismic site response, based on consideration of site specific conditions and information obtained from geotechnical site investigations.

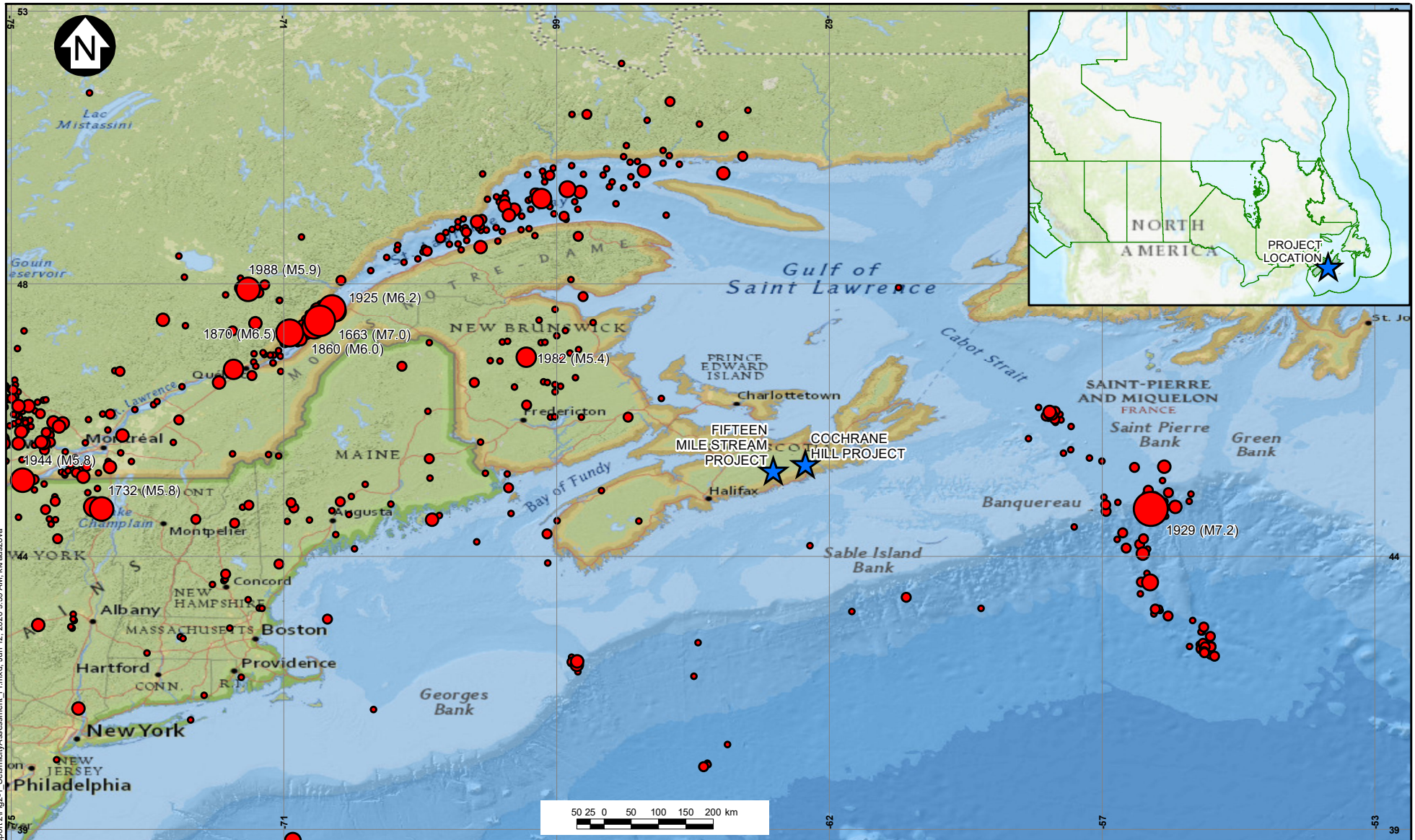

LEGEND:

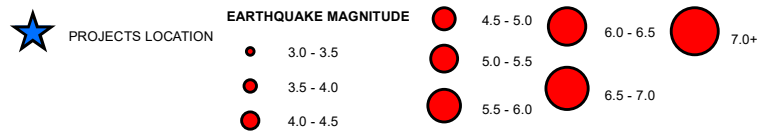

NOTES:

1. HISTORICAL EARTHQUAKE DATA PROVIDED BY THE NRCAN DATABASE SINCE 1985. ADDITIONAL LARGE MAGNITUDE EARTHQUAKES RECORDED IN 1663, 1732, 1860, 1870, 1925, 1929, 1944, AND 1982 ARE INCLUDED.
2. EARTHQUAKE DATA PROVIDED BETWEEN LATITUDE 52° AND 39°, AND LONGITUDE -55° AND -75°.
3. BASE MAP: ESRI WORLD STREET MAP.
4. COORDINATE GRID IS IN METRES. COORDINATE SYSTEM: GCS WGS 1984.
5. THIS FIGURE IS PRODUCED AT A NOMINAL SCALE OF 1:10,000,000 FOR 8.5x11 (LETTER) PAPER. ACTUAL SCALE MAY DIFFER ACCORDING TO CHANGES IN PRINTER SETTINGS OR PRINTED PAPER SIZE.

ATLANTIC MINING NS CORP.

FIFTEEN MILE STREAM PROJECT

HISTORICAL SEISMICITY OF NOVA SCOTIA AND SURROUNDING REGIONS

REV	DATE	ISSUED WITH REPORT	DESCRIPTION	DESIGNED	DRAWN	REVIEWED
1	12JUN20			KK	KK	AS2



PIA NO. VA101-7084	REF. NO. 2
FIGURE 2.1	
	REV 1

S:\NEDP_M1\1010070804\GIS\Figs\Report 2\Fig2-1_SeismicityAssessment_r1.mxd; Jun 12, 2020 9:39 AM; k.krausova

Table 2.5 Summary of Seismic Design Parameters

Return Period (Years)	Annual Exceedance Probability (AEP) (%)	Peak Ground Acceleration (PGA) (g)
100	1	0.008
475	0.21	0.027
1,000	0.1	0.035
2,475	0.04	0.061
5,000	0.02	0.088
10,000	0.01	0.129

NOTES:

1. SPECTRAL AND PEAK GROUND ACCELERATIONS FOR RETURN PERIODS UP TO 2,475 YEARS OBTAINED FROM THE SEISMIC HAZARD DATABASE OF NATURAL RESOURCES CANADA. SPECTRAL AND PEAK GROUND ACCELERATIONS FOR RETURN PERIODS OF 5,000 AND 10,000 YEARS CALCULATED USING EZ-FRISK.
2. PEAK GROUND ACCELERATIONS ARE FOR "FIRM GROUND" (SITE CLASS C) WITH SHEAR WAVE VELOCITY V_{s30} OF 450 M/S, AS DEFINED BY THE NATIONAL BUILDING CODE OF CANADA (NRCC, 2015).
3. VALUES OF SPECTRAL AND PEAK GROUND ACCELERATION SHALL BE USED TO 3 SIGNIFICANT FIGURES.

3.0 PROJECT PHASES AND DAM CLASSIFICATION

3.1 PROJECT PHASES

3.1.1 MINE DEVELOPMENT SEQUENCE

The sequence of mine development, mine waste production and management, and associated mine water management is essential to the design and staged construction of the TMF and ancillary water management facilities. There were four phases of the mine development sequence that were considered:

- Construction (preproduction period commencing approximately one year prior to mine operation)
- Operations (production period from approximately Year One to Year Seven)
- Reclamation/Closure (active period of reclamation beginning immediately following cessation of mining and mill operation and extending until surface reclamation is complete and the open pit is flooded with water to form a pit lake)
- Post-Closure (long-term closure condition, once the pit lake has filled and water management strategy reaches a steady-state condition)

3.1.2 PHASES IN THE LIFE OF A TAILINGS FACILITY DAM

A TMF progresses through several phases throughout its life cycle. The succession of phases in the life cycle includes: project conception and planning; design; initial construction; operation and ongoing construction; closure and post-closure. For some projects, the life cycle may also include temporary closure. In the case of TMFs, the life cycle, include the closure and post-closure phases, can extend to decades or centuries, unless the facility is removed at some point in the future if tailings are reprocessed or relocated.

The various phases of the life cycle can be described as follows, as per *Guide to the Management of Tailings Facilities* (Mining Association of Canada (MAC), 2017):

- **Project Conception and Planning:** Beginning at the outset of planning of a proposed mine and is integrated with conception and planning for the overall site, including the mine plan and plans for ore processing.
- **Design:** Begins once the location and technology for the TMF have been selected and occurs in concert with detailed planning of all aspects of the proposed mine. Detailed engineering designs are prepared for all aspects of the TMF and associated infrastructure.
- **Initial Construction:** Construction of structures and infrastructure that need to be in place before tailings deposition commences. This includes, for example, removal of vegetation and overburden, and construction of starter dams, tailings pipelines, access roads, and associated water management infrastructure.
- **Operations and Ongoing Construction:** Tailings are transported to, and deposited in, the tailings facility. Tailings dams may be raised, or new tailings cells added as per the design. Depending on the overall mine plan, the operations and ongoing construction phase of a TMF may or may not coincide with the period of commercial operations of the mine.
- **Standby Care and Maintenance:** The mine has ceased commercial operations and the deposition of tailings into the facility is not occurring. The Owner expects to resume commercial operations at some

point in the future, so surveillance and monitoring of the TMF continue, but the facility and associated infrastructure are not decommissioned, and the closure plan is not implemented.

- **Closure:** Begins when deposition of tailings into the facility ceases permanently. The facility and associated infrastructure are decommissioned, and key aspects of the closure plan are implemented, including:
 - Transitioning for operations to permanent closure
 - Removal of key infrastructure such as pipelines
 - Changes to water management or treatment
 - Recontouring or revegetation of tailings and any containment structures or other structural elements
- **Passive Care (Post-closure):** Begins when decommissioning work is complete, key aspects of the closure plan have been implemented, and the tailings facility has transitioned to long-term maintenance and surveillance. During post-closure, responsibility for a tailings facility could transfer from the Owner to jurisdictional control.

The life cycle of a TMF is shown on Figure 3.1 below (reproduced from MAC, 2017).

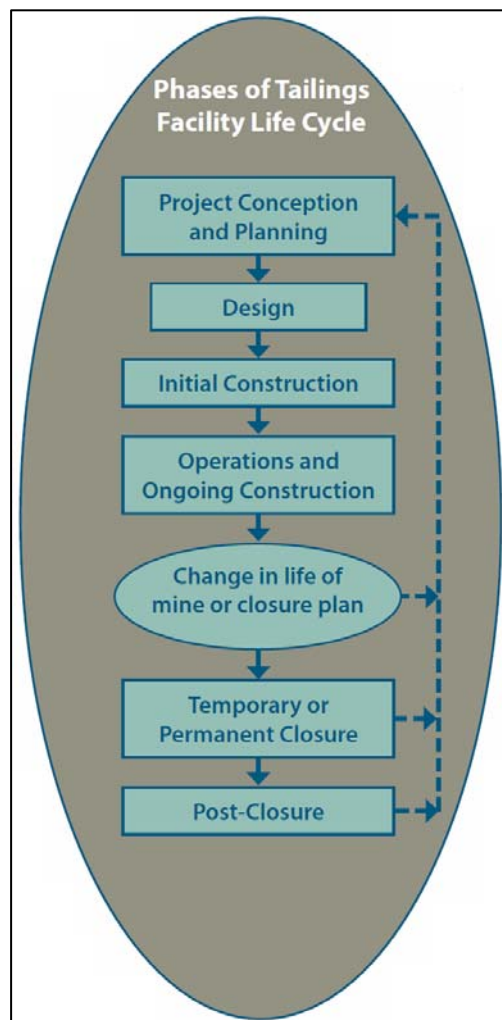

Figure 3.1 Phases in the Life of a Tailings Management Facility (MAC, 2017)

3.2 DAM CLASSIFICATION

3.2.1 METHODOLOGY

Dam classification was carried out to determine the minimum target levels for design earthquake and flood events for the TMF based on classification criteria provided by the Canadian Dam Association (CDA, 2013 and 2014). The TMF dam classification considers the potential incremental consequences of an embankment failure defined as the total adverse effect from an event with dam failure compared to the adverse effect that would have resulted from the same event had the dam not failed. Four areas are evaluated under the conditions; potential impacts to downstream populations, potential loss of life, potential loss of environmental or cultural values, and potential infrastructure or economic losses, as shown on Table 3.1 (reproduced from the Dam Safety Guidelines (CDA, 2013)).

Table 3.1 Dam Classification (as per CDA, 2013)

Dam Class	Population at Risk ¹	Incremental Losses		
		Loss of Life ²	Environmental and Cultural Values	Infrastructure and Economics
Low	None	0	Minimal short-term loss. No long-term loss.	Low economic losses; area contains limited infrastructure or services.
Significant	Temporary only	Unspecified	No significant loss or deterioration of fish or wildlife habitat. Loss of marginal habitat only. Restoration in kind highly possible.	Losses to recreational facilities, seasonal workplaces, and infrequently used transportation routes.
High	Permanent	10 or fewer	Significant loss or deterioration of <i>important</i> fish or wildlife habitat. Restoration or compensation in kind highly possible.	High economic losses affecting infrastructure, public transportation, and commercial facilities.
Very High	Permanent	100 or fewer	Significant loss or deterioration of <i>critical</i> fish or wildlife habitat. Restoration or compensation in kind possible but impractical.	Very high economic losses affecting infrastructure or services (e.g., highway, industrial facility, storage facilities for dangerous substances).
Extreme	Permanent	More than 100	Major loss of <i>critical</i> fish or wildlife habitat. Restoration or compensation impossible.	Extreme losses affecting critical infrastructure or services (e.g. hospital, major industrial complex, major storage facilities for dangerous substances).

NOTES:

1. DEFINITIONS FOR POPULATION AT RISK:

NONE – NO IDENTIFIABLE POPULATION AT RISK, NO POSSIBILITY OF LOSS OF LIFE OTHER THAN THROUGH UNFORESEEABLE MISADVENTURE.

TEMPORARY – PEOPLE ARE ONLY TEMPORARILY IN THE DAM-BREACH INUNDATION ZONE (E.G. SEASONAL COTTAGE USE, TRANSPORTATION ROUTES, RECREATION).

PERMANENT – POPULATION AT RISK IS ORDINARILY LOCATED IN THE DAM-BREACH INUNDATION ZONE (E.G. PERMANENT RESIDENTS).

2. IMPLICATIONS FOR LOSS OF LIFE:

UNSPECIFIED – THE APPROPRIATE LEVEL OF SAFETY REQUIRED AT A DAM WHERE PEOPLE ARE TEMPORARILY AT RISK DEPENDS ON THE NUMBER OF PEOPLE, EXPOSURE TIME, NATURE OF ACTIVITY AND OTHER CONDITIONS. HIGHER CLASSES COULD BE APPROPRIATE DEPENDING ON REQUIREMENTS.

The Inflow Design Flood (IDF) and Earthquake Design Ground Motion (EDGM) selection is governed by the dam classification. Target levels for these events are outlined in Table 3.2 (reproduced from the Technical Bulletin – Application of Dam Safety Guidelines to Mining Dams (CDA, 2014)).

Table 3.2 Target Levels for Flood and Earthquake Hazards (CDA, 2014)

Dam Class	Annual Exceedance Probability (AEP)			
	Construction and Operations		Passive Care (i.e. Post-Closure)	
	IDF ^{2,3}	EDGM	IDF ^{2,3}	EDGM
Low	1/100	1/100	1/3 between 1/975 and PMF	1/1,000
Significant	Between 1/100 and 1/1,000	Between 1/100 and 1/1,000	1/3 between 1/1,000 and PMF	1/2,475 ⁵
High	1/3 between 1/1,000 and PMF	1/2,475 ⁵	2/3 between 1/1,000 and PMF	1/2 Between 1/2,475 ⁵ and 1/10,000 or MCE ⁶
Very High	2/3 between 1/1,000 and PMF	1/2 Between 1/2,475 ⁵ and 1/10,000 or MCE ⁶	PMF	1/10,000 or MCE ⁶
Extreme	PMF	1/10,000 or MCE ⁶	PMF	1/10,000 or MCE ⁶

NOTES:

1. ACRONYMS: PMF (PROBABLE MAXIMUM FLOOD), AEP (ANNUAL EXCEEDANCE PROBABILITY), MCE (MAXIMUM CREDIBLE EARTHQUAKE).
2. SIMPLE EXTRAPOLATION OF FLOOD STATISTICS BEYOND 1/1,000 AEP IS NOT ACCEPTABLE.
3. PMF HAS NO ASSOCIATED AEP.
4. MEAN VALUES OF THE ESTIMATED RANGE IN AEP LEVELS FOR EARTHQUAKES SHOULD BE USED. THE EARTHQUAKES WITH THE AEP AS DEFINED ABOVE ARE INPUT AS CONTRIBUTORY EARTHQUAKES TO DEVELOP EARTHQUAKE DESIGN GROUND MOTION (EDGM) PARAMETERS.
5. THE 1/2,475 AEP EARTHQUAKE HAS BEEN SELECTED FOR CONSISTENCY WITH SEISMIC DESIGN LEVELS GIVEN IN THE NATIONAL BUILDING CODE OF CANADA (NBCC, 2010).
6. MCE HAS NO ASSOCIATED AEP.

3.2.2 FIFTEEN MILE STREAM DAM CLASSIFICATION

The TMF embankment at the FMS Project has been assigned a dam classification of **HIGH**. The potential incremental losses are as follows:

- **Population at Risk:** The population at risk was determined based on the likelihood of people being in the potential inundation zone. There is no permanent population downstream of the TMF. Temporary population will be present in the form of mine workers, and users of nearby roads. Therefore, the risk to population was determined to be **Significant**.
- **Loss of Life:** The loss of life factor considers the most probable size of the population at risk if failure occurs. For the FMS Project site, this includes mine workers and users of nearby roads, and is estimated to be fewer than 10 people at any one time. The potential loss of life was therefore determined to be **HIGH**.
- **Environmental and Cultural Values:**
 - Environmental loss considers the potential loss or deterioration of fish and wildlife habitat in the affected area. In the event of a breach of the TMF embankment, tailings and supernatant water will flow north into Seloam Brook and subsequently into the open pit. Seloam Brook has evidence of

brook trout and white sucker populations, restoration or compensation for impacted fish habitat is anticipated to be highly possible. Therefore, the impact on wildlife was classified as **HIGH**.

- Cultural losses are based on the potential impact to areas of cultural significance in the inundation zone. No considerable impact on culturally sensitive areas is predicted, therefore potential loss of cultural values was determined to be **Low**.
- **Infrastructure and Economics:** Infrastructure and economic losses consider potential damage to transportation routes, commercial and recreational facilities, other infrastructure, services, and storage facilities. Minor highways and seasonal roads are located downstream of the TMF along potential breach flow paths to the south or the northeast. Therefore, the infrastructure and economic losses were determined to be **Significant**.

The dam classification is used to determine the IDF and EDGM for the TMF. The following minimum target design flood and earthquake levels were adopted from the CDA guidelines (CDA, 2013 and 2014) for a **HIGH** dam hazard classification for the construction and operations phases of the project:

- IDF: 1/3 between the 1/1,000-year return period event and the Probable Maximum Flood (PMF)
- EDGM: the 1/2,475-year return period seismic event

For a **HIGH** dam classification during the passive care phase (i.e. post-closure), CDA guidelines suggest the following minimum target levels that the TMF be designed to withstand for seismic and precipitation events.

- IDF: 2/3 between the 1/1,000-year return period event and the PMF
- EDGM: 1/2 between the 1/2,475-year and the 1/10,000-year (or MCE) return period seismic events

4.0 TAILINGS MANAGEMENT FACILITY DESIGN

4.1 GENERAL

The principle design objective of the TMF is to protect the environment during the operations and throughout the closure stage of the project and to achieve effective surface reclamation at mine closure. The preliminary design of the TMF has considered the following requirements:

- Permanent, secure, and total confinement of all tailings solids within an engineered facility
- Control, collection, and removal of free draining liquids from the tailings during operations, for recycling as process water to the maximum practical extent
- Inclusion of monitoring features for all aspects of the facility to verify that performance goals are achieved, and design criteria are met

4.2 DESIGN BASIS

Ore will be processed on site at a nominal production rate of approximately 5,500 tpd to produce gold concentrate for shipment to Touquoy for final leaching. The mining and processing of ore will produce approximately 13.4 million tonnes (Mt) of tailings and 24.4 Mt of waste rock over a mine life of approximately seven years.

The TMF will be developed in three stages over the mine life using downstream methods of construction. The staged approach will allow for an observational approach to construction with the following advantages:

- The ability to refine design, construction, and operating methodologies as experience is gained with local conditions and constraints
- The ability to adjust plans at a future date to remain current with evolving best practices (engineering and environmental)
- The ability to use mined waste rock in the on-going construction of the facility

Tailings will be disposed of in the TMF, and waste rock and overburden will be used to construct the TMF embankment with the surplus material not required for construction stored in on-land waste stockpiles. An initial settled dry density of the tailings of approximately 1.3 tonnes per cubic metre (t/m^3) was adopted for development of the filling schedule and facility staging based on recent project experience. This provides a reasonably conservative estimate of storage capacity and subsequent filling rate. Long-term consolidation may increase the dry density of the tailings above the initial settled density thereby increasing the available storage capacity of the facility. Actual field conditions will depend on a number of conditions, including rate of rise, depth of deposited tailings, and tailings segregation during deposition into the impoundment.

A high-level summary of the design basis and operating criteria for the TMF is given in Table 4.1 and additional details are included in Appendix B.

Table 4.1 Design Basis and Operating Criteria

Parameter	Units	Value
Mill Throughput (typical)	tpd	5,500
Life of Mine	Years	7
Ore Mined	Mt	13.4
Total Tailings	Mt	13.4
Tailings Solids Content	% (by weight)	38
Tailings Dry Density	t/m ³	1.3
Waste Rock Mined	Mt	24.4
Waste Rock Dry Density	t/m ³	2.2
TMF Embankment Crest Width	m	15
TMF Embankment Side Slopes	-	2H:1V D/S; 2.5H:1V U/S
Environment Design Flood (EDF)	mm	571
Normal Operating Pond Volume	m ³	800,000
Maximum Design Earthquake (MDE)	g	0.095

4.3 EMBANKMENT STAGING AND FILLING SCHEDULE

4.3.1 GENERAL

The four planned stages of TMF embankment construction are shown along with the TMF filling schedule on Figure 4.1. The filling schedule and timing for staged expansions must be reviewed on an on-going basis during operations. The actual rate of filling may vary, depending on a variety of operating factors, including:

- Mill throughput
- Settled tailings density
- Tailings surface slopes
- Tailings consolidation rates

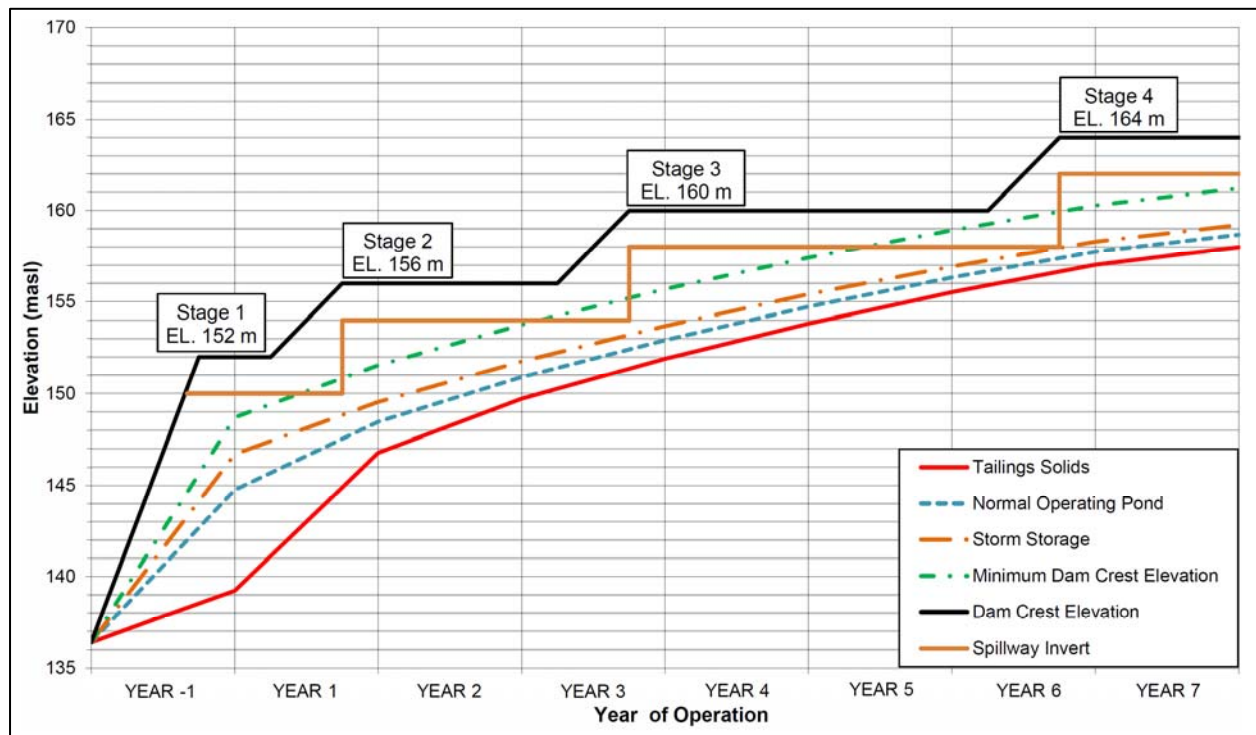

NOTES:

1. TAILINGS TONNAGE AND MILL RAMP UP SCHEDULE BASED ON JUNE 2019 PRODUCTION SCHEDULE.
2. AVERAGE SETTLED TAILINGS DENSITY ASSUMED TO BE 1.3 TONNES PER M³ DURING OPERATIONS.
3. MINIMUM DAM CREST ELEVATION ASSUMED 2 METRES ABOVE REQUIRED ELEVATION FOR STORM STORAGE (INCLUDES ALLOWANCE FOR SPILLWAY DEPTH).

Figure 4.1 TMF Filling Schedule

4.3.2 EMBANKMENT CONSTRUCTION

The TMF embankment will be constructed as a zoned earthfill-rockfill structure. The embankment will include an upstream liner system consisting of a low-permeability till layer and non-woven geotextile fabric. The maximum Stage One embankment height was estimated to be approximately 16 m. The liner will extend from the upstream toe of the embankment into the TMF basin for a length of approximately three times the height of the Stage One embankment to control seepage gradients prior to the development of the tailings beaches. The embankment height will be raised over the life of the mine in three additional stages (of approximately four m each) to a maximum height of approximately 28 m at Stage Four.

The embankment will be constructed with a crest width of approximately 15 m to allow for single lane haul truck traffic within safety berms and pipeline routes. The embankment will be primarily constructed with Non-PAG pit run waste rock. Filter and Transition Zones consisting of filter sand and drain gravel will be placed on the upstream face of the embankment. A liner material consisting of compacted, low-permeability till will be constructed on top of the filter zone material. A second layer Non-PAG waste rock will be constructed to complete the upstream face of the embankment, with the geotextile layer separating the till and the waste rock.

The embankment is shown in plan view on Figure 4.2 and a typical cross-section is shown on Figure 4.3.

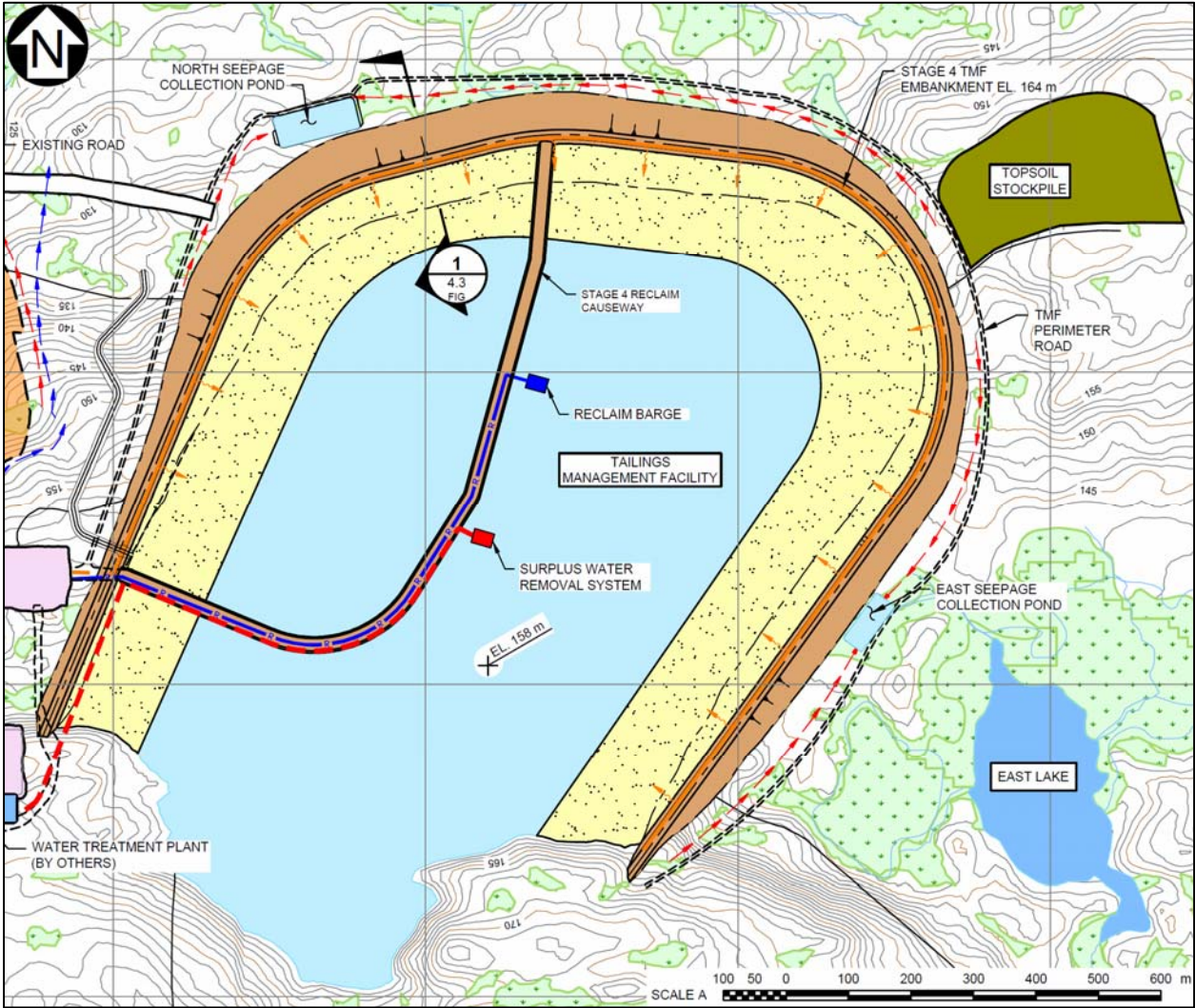
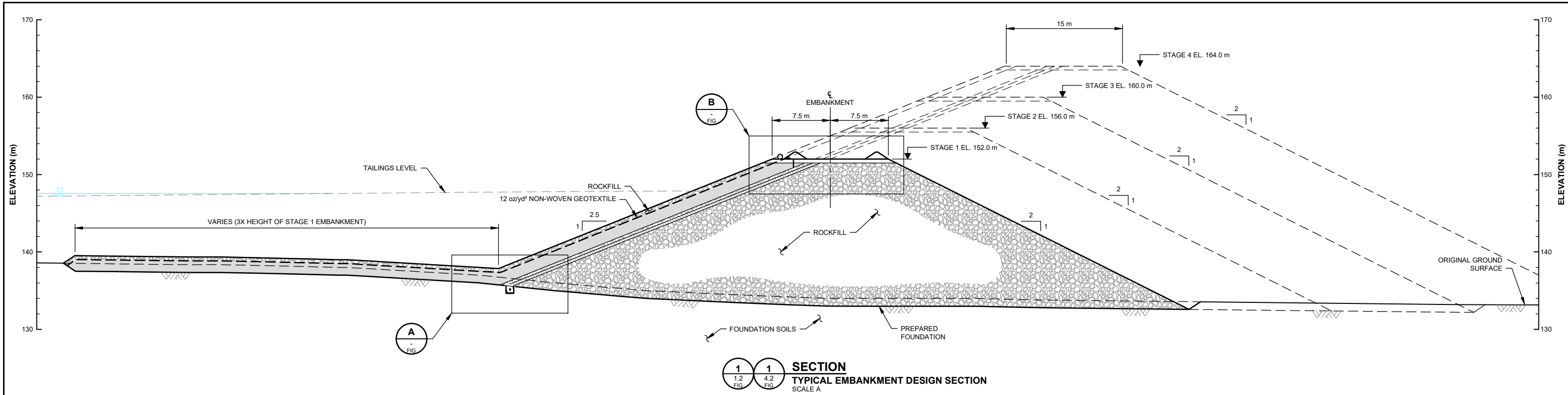
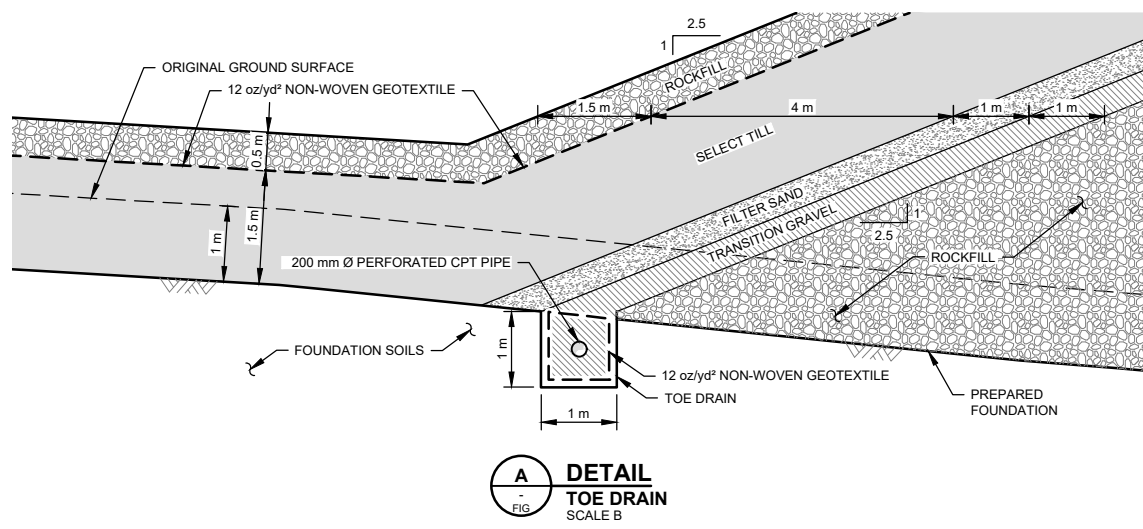

Figure 4.2 TMF General Arrangement



SECTION 1.1
1.2 FIG 4.2 FIG
TYPICAL EMBANKMENT DESIGN SECTION
SCALE A



DETAIL A
TOE DRAIN
SCALE B

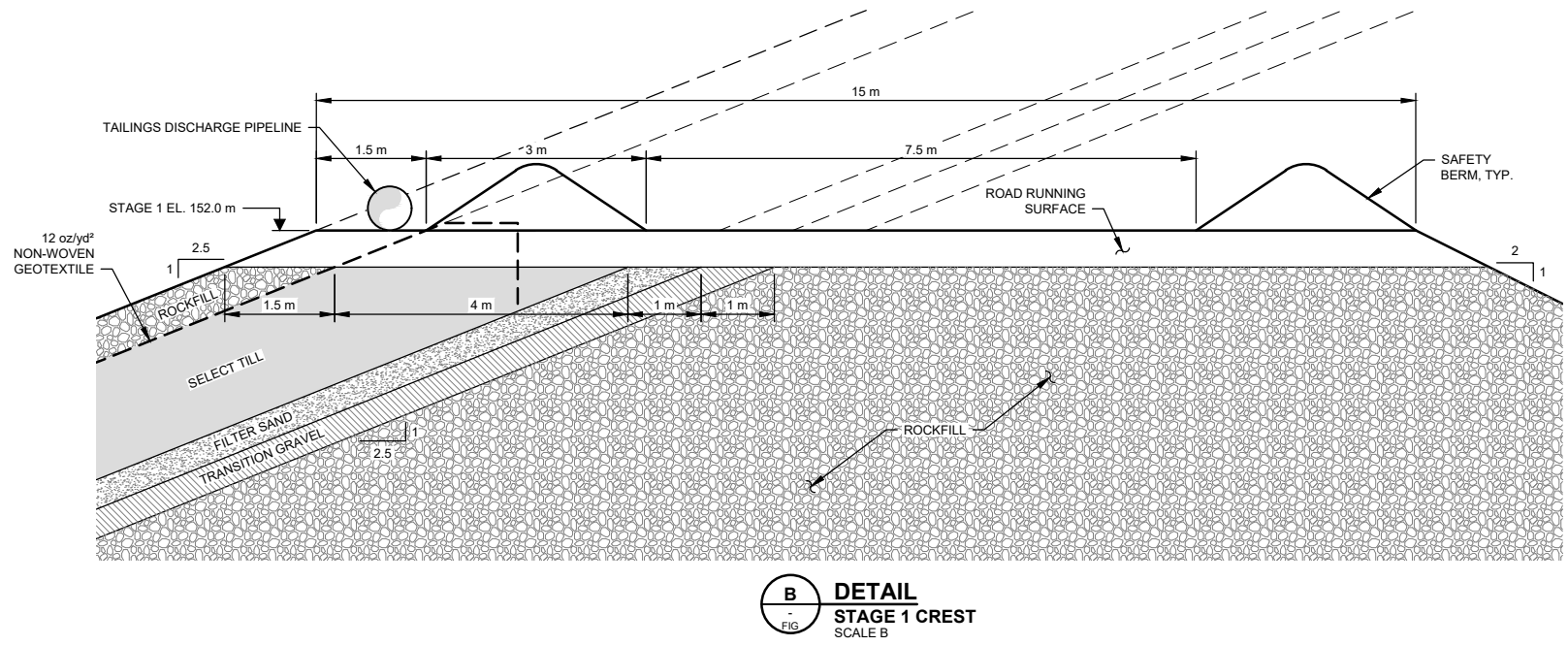

DETAIL B
STAGE 1 CREST
SCALE B

- LEGEND:**
- ROCKFILL
 - SELECT TILL
 - FILTER SAND
 - TRANSITION GRAVEL

NOTES:
1. DIMENSIONS AND ELEVATIONS ARE IN METRES, UNLESS NOTED OTHERWISE.

FOR INFORMATION ONLY



ATLANTIC MINING NS CORP.	
FIFTEEN MILE STREAM PROJECT	
TMF EMBANKMENT CROSS-SECTION	
P/A NO. VA101-708/4	REF NO. 2
FIGURE 4.3	
	REV 1

SAVED: M:\110100708\04\AA\Acad\FIGS\B35_6\11\2020 3:49:51 PM - SCAMMAYO PRINTED: 6/12/2020 10:48:02 AM FIG 4.3 - SCAMMAYO ACAD VERSION: 23.0S (LMS TECH)

REV	DATE	DESCRIPTION	DESIGNED	DRAWN	REVIEWED
1	12JUN'20	ISSUED WITH REPORT	JEF	SC	DDF

4.3.3 FOUNDATION PREPARATION

Topsoil materials will be excavated beneath the entire TMF embankment and upstream TMF basin liner footprint to a depth of approximately 0.5 m. Topsoil will be stockpiled for use in reclamation. Loose or unsuitable overburden materials (i.e. wetland material) will be excavated completely in wetland areas beneath the embankment footprint and either stockpiled or disposed within the TMF basin. Any suitable construction materials for the starter embankment that are encountered during sub-excavation will be stockpiled separately.

4.4 TMF EMBANKMENT SPILLWAY

The TMF has been designed to store stormwater flows from an Environmental Design Flood (EDF) event in addition to the normal operating pond volume required to provide a source of reclaim water for mill operations at the Plant Site. A spillway will be constructed at the in the TMF embankment for each embankment stage. The spillway is designed to pass extreme storm events from the TMF (events exceeding the EDF).

The EDF for the TMF has been estimated as a one-in-200 year 24-hour precipitation event (184 mm) in addition to the estimated maximum mean monthly precipitation (387 mm) over the entire TMF catchment.

Flood events exceeding the design storage capacity of the TMF, up to the peak flow from a PMF event, will be conveyed from the TMF through an emergency discharge spillway at the southwestern abutment of the TMF embankment. The spillway channel will convey the flows past the plant site and discharge into the Seloam Brook drainage area where they will merge with flows in the Seloam Brook Diversion system.

An alternative to including a staged embankment spillway is to include additional contingency storage within the TMF to allow for storage of the Inflow Design Flood (IDF) during operations, to limit release of water from the facility to controlled release through the Reclaim Water System (RWS) and the Surplus Water Management System (SWMS). A suitable Operational Preparedness and Response Plan for Upset Water Levels will be required in this scenario.

The spillway channel alignment is shown on Figure 4.2.

4.5 NON-CONTACT WATER DIVERSION CHANNELS

Non-contact water will be diverted around site facilities to the maximum practicable extent to minimize the impact to local water courses and the unnecessary collection of fresh water. Diversion channels will collect and divert runoff from undisturbed catchment areas for precipitation events up to a one-in-200-year precipitation event.

4.6 SELOAM BROOK DIVERSION

The proposed open pit is located in the Seloam Brook drainage area. Seloam Brook has evidence of being fish habitat for brook trout and white sucker species, so for remediation purposes and to minimize impacts to environment, the alignment of Seloam Brook will be altered and diverted around the limits of the proposed open pit.

Seloam Brook will be diverted through the construction of a raised perimeter berm along the east, north and west of the open pit which will divert flows from Seloam Brook around the open pit to the north of the

pit. This channel will be constructed and upgraded as necessary to provide sufficient flow capacity and offset for fish habitat.

Multiple berm alignments were investigated to divert Seloam Brook around the open pit. The currently proposed berm alignment and crest elevation sufficiently realigns and diverts flows from a one-in-200 year, 24-hour precipitation event away from the mine working areas.

The one-in-200 year, 24-hour precipitation event that was evaluated results in overbank flows for the natural stream channels. The maximum depth of water as a result of this storm event is approximately 1.35 m, which still leaves a minimum of 1.0 m freeboard along the entire berm alignment.

The maximum velocities along the berm during the one-in-200 year, 24-hour precipitation event are in the range of 0.5 – 0.7 m/s. Critical areas along the berm that may experience these maximum velocities and may require additional bank protection from erosion include the middle section of the berm directly north of the open pit and the western section of the berm immediately prior to the divide in the natural Seloam Brook.

4.7 RUNOFF COLLECTION AND SEEPAGE MANAGEMENT

Contact water from site facilities will be collected in a system of ditches that convey collected flows to water management ponds. The ponds were designed to store catchment runoff for the one-in-10 year 24-hour storm event (116 mm) (conveyed by systems of collection ditches) plus direct precipitation for the one in 200-year 24-hour storm event (184 mm) on the surface of the ponds.

The ponds and ditches downstream of the TMF embankment will also be sized to collect and manage seepage flows through the TMF embankment in addition to runoff and precipitation. The seepage collection ponds were sized to collect flows up to a one in 10-year precipitation event falling on the contributing catchment area. Collected flows will be pumped back to the TMF supernatant pond over a 10-day drawdown period.

4.8 TAILINGS DISTRIBUTION SYSTEM

The Tailings Distribution System (TDS) will deliver the tailings to the TMF. Tailings will be discharged from the crest of the embankment to develop tailings beaches along the inside perimeter of the TMF embankment. The TDS consists of three primary components: a tailings pump station (if/when required), tailings conveyance pipeline and discharge spigots. The TDS and the configuration of discharge spigots will evolve during operations as the TMF embankment develop and as operating procedures are refined.

Tailings discharge will be rotational, whereby a spigot (or multiple spigots) will be used for a while, then discharge is moved to the next spigot etc. This process will be repeated to establish suitable subaerial tailings beaches separating the supernatant pond from the embankment. Tailings will be selectively discharged to maintain a wetted beach surface and to limit oxidation of previously deposited tailings.

The design of the TDS was included in the design of the process plant, which was completed by others.

4.9 RECLAIM WATER SYSTEM

The Reclaim Water System (RWS) allows for the reclaim of supernatant for use in the mill. Water will be reclaimed from the TMF supernatant pond through pumps on skidders located along the reclaim water causeway running through the centre of the TMF. Reclaimed water will be pumped back to the mill for use

in processing ore. The design of the RWS was included in the design of the process plant, which was completed by others.

The reclaim water causeway is a 20 m wide internal berm constructed continuously in approximately two m high lifts during operations to provide access to the deepest portions of the supernatant pond.

4.10 SURPLUS WATER MANAGEMENT SYSTEM

The Surplus Water Management System (SWMS) allows for the removal of excess water from the TMF supernatant pond during operations to maintain target operating pond volumes, tailings beach length, and minimum freeboard requirements. Surplus water will be removed by pumping water to a Water Treatment Plant (WTP) located near the Plant Site, if required to meet discharge criteria. Water will be discharged to Anti-Dam Flowage via a gravity discharge pipeline as shown on Figure 4.4.

The SWMS includes a 1,000 m long HDPE pipeline for the surplus water removal from the TMF, with a skid-mounted centrifugal pump. Surplus water will be discharged, following treatment at the WTP if required, to Anti-Dam Flowage via a 2,000 m long HDPE gravity discharge pipeline.

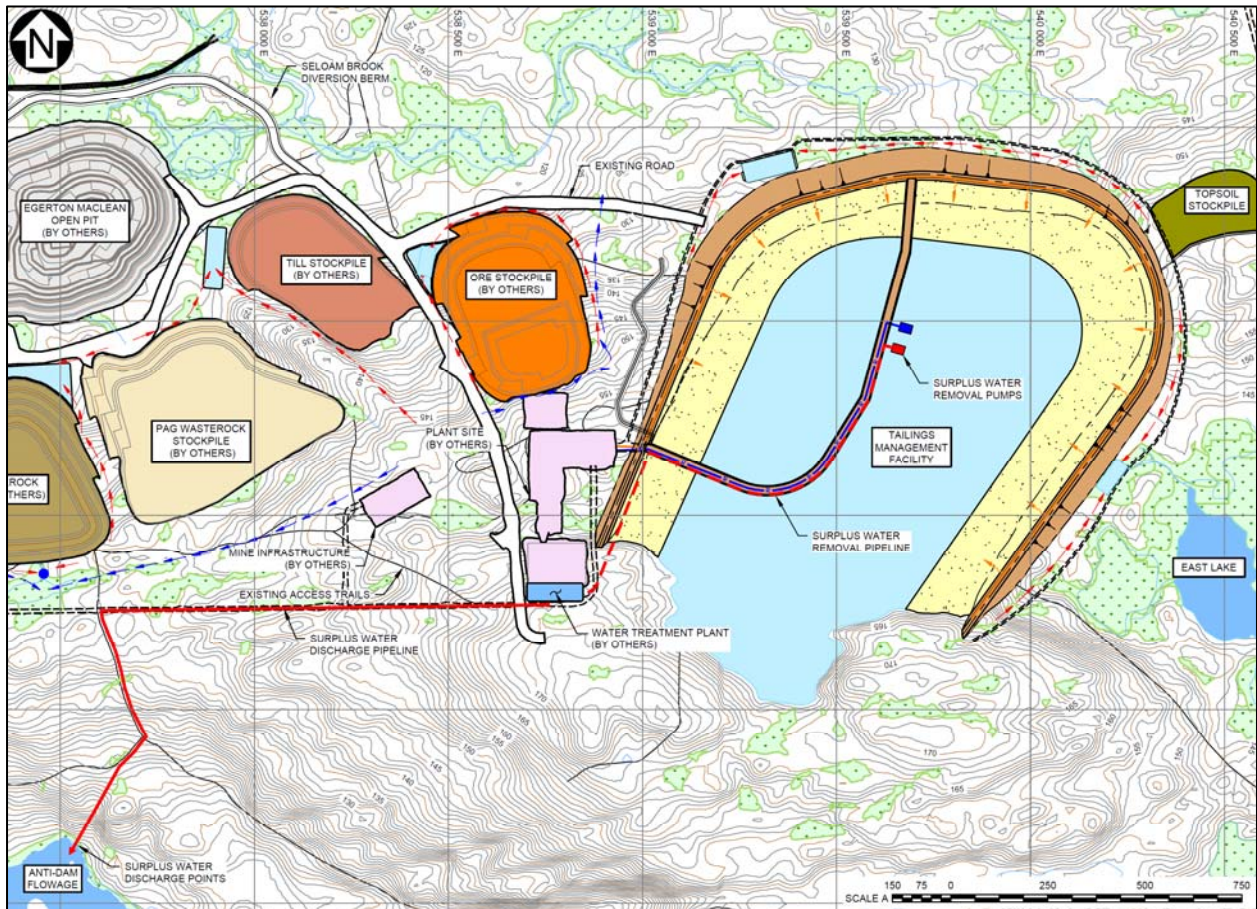

Figure 4.4 Surplus Water Management System – Plan

4.11 INSTRUMENTATION AND MONITORING

Instrumentation will be installed in the TMF embankment and underlying foundations and monitored during all phases of the project. Monitoring data will be used to assess performance and to identify any conditions that differ from those assumed during design and analysis. Amendments to the ongoing designs, operating strategies and/or remediation work can be implemented to respond to changing conditions, should the need arise. The following are types of instrumentation that may be installed:

- Survey Monuments: To evaluate the performance of the embankment with respect to movement, settling, etc.
- Vibrating Wire Piezometers: To monitor pore pressures within the TMF embankment and foundation, and to evaluate performance of the till liner
- Slope Inclinometers: To monitor deformation and subsurface movement in the TMF embankment
- Flow meters: To monitor effectiveness and performance of pipeline systems
- Pond level indicators: To monitor supernatant pond level to assess performance and volume of supernatant pond

5.0 WATER MANAGEMENT PLAN AND MINE SITE WATER BALANCE

5.1 GENERAL

Site water management planning considers the management of surface water at the FMS Project site during the construction, operations, closure, and post-closure phases of the project. Surface water will be managed by constructing systems of ditches, ponds, berms, and pump and pipeline systems, and by selective grading disturbed surfaces. Two types of surface water are considered in the water management plan:

- Contact water, which is water impacted by mine workings or disturbed areas (open pit dewatering flows; TMF seepage; runoff from the waste rock stockpile, ore stockpile, till stockpile, topsoil stockpiles, TMF embankment, etc.)
- Non-contact water, which is runoff from undisturbed areas

The water management plan forms the basis of a site wide water balance, which has been developed on a daily basis and considers a range of climatic conditions consistent with historic variability in the project area. The primary goal of the water balance model is to estimate the anticipated volume of surplus water that must be released from the mine site on an annual basis in order to manage the inventory of water stored in the TMF within a target range consistent with the design basis of the facility. The development of the water balance model is discussed further in Section 5.3.

5.2 WATER MANAGEMENT PLAN

5.2.1 TAILINGS MANAGEMENT FACILITY

Tailings slurry from the Process Plant will be discharged into the TMF at a nominal solids content of 38% solids by weight, and water will be reclaimed from the TMF supernatant pond to be used as mill process water. Additional inflows to the TMF supernatant pond in the water balance model include:

- Direct precipitation on the supernatant pond
- Water pumped from the four Water Management Ponds (WMP) and two Seepage Collection Ponds (SCP)
- Runoff from the tailings beach, TMF embankment, and undiverted contributing catchment areas

Additional inflows due to consolidation of tailings were not considered in this iteration of the water balance model because consolidation modelling based on laboratory consolidation test results has not yet been completed. Consolidation seepage will be incorporated into water balance model updates at later stages of design. Outflows from the TMF supernatant pond in the water balance model included evaporation from the supernatant pond, reclaim water pumped to the mill, water retained in the tailings voids, seepage, and surplus water discharge to the environment.

A stage storage curve was developed for the TMF layout, mill throughput, and estimated tailings properties. The stage storage curve for the TMF is the relationship between the volume and the surface area of the impoundment. Figure 5.1 shows the stage storage relationship for the TMF.

The TMF supernatant pond has a maximum normal operating capacity of 800,000 m³. The water balance model treats the maximum normal operating capacity as a maximum allowable volume to estimate the volume of surplus water that needs to be discharged to maintain water inventory below this volume. A minimum pond volume of 270,000 m³ was assumed for the TMF from the start to the end of operations. The minimum pond volume was calculated based on the mill water requirement for one month of mill operations. Seepage loss was represented in the water balance model by an outflow of 10 L/s with a 90% seepage recovery rate. The recovered seepage was assumed to report to the two SCPs: the East SCP (50%) and the North SCP (50%).

The water inventory in the TMF was estimated to fluctuate between 270,000 m³ (minimum) and 800,000 m³ (maximum) under the water balance flow scenarios, which are described in further detail in Section 5.3. The maximum estimated volume typically occurs during spring freshet and the minimum volume typically occurs during the winter months.

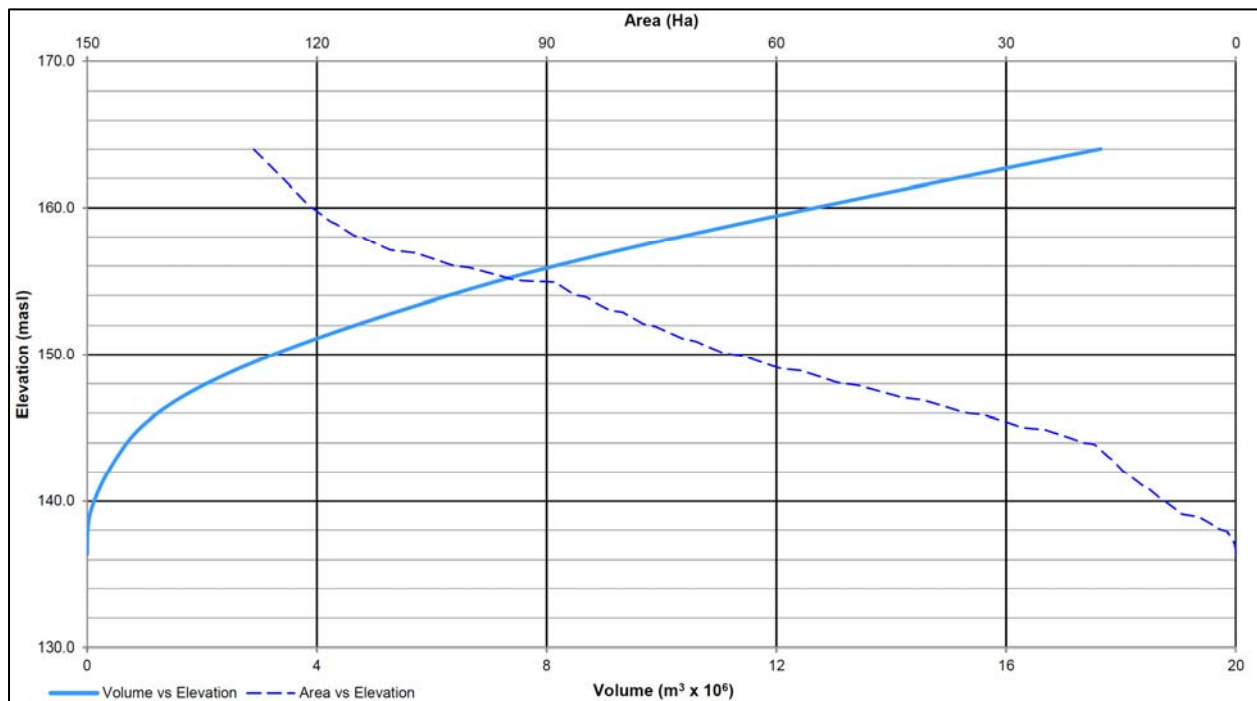

Figure 5.1 TMF Stage Storage Curve

5.2.2 SEEPAGE COLLECTION PONDS

Collection ditches along the perimeter road around the toe of the TMF embankment will collect runoff from the TMF embankments and seepage through the TMF embankment and foundation. The collection ditches will convey these flows to the two SCPs. Flows collected in the ponds (including precipitation on the surface of the pond) will be pumped back to the TMF supernatant pond. The North SCP has a maximum volume of 20,000 m³ and the East SCP has a maximum volume of 15,000 m³.

5.2.3 PLANT SITE WATER MANAGEMENT

Water required for mill operations will be sourced from the Plant Site Collection Pond (PSCP), reclaim from the TMF supernatant pond, water in ore, and freshwater makeup from a nearby source. Freshwater makeup requirements are for clean (i.e. non-contact) water required for various components in the mill process and was estimated as a percentage of total mill requirements (approx. 5.8% of total mill requirements). Water in ore is the estimated volume of water entrained in the ore (i.e. the moisture content of the ore as it enters the mill) and is estimated to be a moisture content of 2.5%. Both the freshwater fraction and water in the ore fraction values were adopted from the Touquoy Mine water balance (Stantec, 2016) under the assumption that the ore properties and mill requirements are similar for both projects. The reclaim water requirement from the TMF supernatant pond is the balance of mill water requirements less the water in ore and the makeup water requirement.

The only outflow from the Plant Site is the water in tailings that reports to the TMF as a slurry (nominal solids content of 38% solids by weight).

Since the design volume of the PSCP is currently unknown, it was assumed that the PSCP will not store water and that all inflows to the PSCP are conveyed directly to the mill. Inflows to the PSCP are direct precipitation on the pond surface and catchment runoff (both from undiverted natural catchment areas and from the disturbed footprint of the Plant Site). An assumed plan area of 7,500 m² was used to evaluate the direct precipitation and evaporation of the PSCP for inclusion in the water balance model.

5.2.4 OPEN PIT WATER MANAGEMENT

Inflows to the open pit include groundwater inflow, pit wall runoff, and catchment runoff. Groundwater inflow rates were based on the Touquoy Mine water balance, which currently uses a groundwater inflow value of 450 m³/day. The groundwater inflow rate was assumed to be 500 m³/day for the FMS water balance for both operations and post-closure, and pit wall and catchment runoff were estimated using the runoff coefficients in Table 5.2 and the equations in Section 5.3.2.

Subsequent to the water balance model being developed, Golder Associates (Golder) refined the groundwater inflow estimates for the FMS open pit, and estimated groundwater inflows of approximately 655 m³/day during operations and 270 m³/day in post-closure (Golder, 2019). These updated values were not considered to have a significant effect on the overall water balance results as they are in the same order of magnitude as the estimate based on Touquoy, so the estimate of 500 m³/day was maintained for the purpose of this water balance.

The maximum dewatering rate of the open pit was assumed to be 50,000 m³/day in the water balance model, which effectively assumes the open pit will remain completely dewatered (i.e. no pond volume is being maintained within the pit). The pit dewatering system will pump water from the pit to the Ore Stockpile Collection Pond (OSCP) where it will be combined with runoff from the Ore Stockpile.

5.2.5 STOCKPILE WATER MANAGEMENT

Three water management ponds are designed to collect runoff from the stockpiles and open pit. The ponds were designed to store catchment runoff for the one in 10-year 24-hour storm event (116 mm) plus direct precipitation for the one in 200-year 24-hour storm event (184 mm).

- The Ore Stockpile Collection Pond (OSCP) collects runoff from the Ore Stockpile, dewatering flows from the Open Pit, and has a maximum design volume of 23,000 m³
- The Till Stockpile Collection Pond (TSCP) collects runoff from the Till Stockpile and has a maximum design volume of 22,000 m³
- The Non-PAG Waste Rock Stockpile Collection Pond (NWRSCP) collects runoff from the Non-PAG Waste Rock Stockpile and has a maximum design volume of 35,000 m³

Water collected in the water management ponds will be pumped to the TMF supernatant pond during operations, up to and including Year Seven. At the end of mining operations (Year Eight and onwards), the Open Pit will be decommissioned and allowed to fill. All water management ponds, and most ditches, will be decommissioned at this time; however, ditches on the south side of the waste rock stockpiles will be maintained to prevent contact seepage from entering the Fifteen Mile Stream watershed to the south. The Non-PAG Waste Rock Stockpile, PAG Waste Rock Stockpile, and Till Stockpile will be reclaimed and the reclaimed runoff will report to the Open Pit. The Ore Stockpile will also be reclaimed, and its reclaimed runoff will report to the environment.

5.2.6 NON-CONTACT WATER DIVERSION

Non-contact water will be diverted around site facilities to the maximum practicable extent to minimize the impact to local water courses. Diversion channels will collect and divert runoff from undisturbed catchment areas for precipitation events up to a one-in-200-year precipitation event.

The Seloam Brook Diversion is the largest non-contact water diversion structure proposed for the FMS Project. The details and design of the Seloam Brook Diversion are discussed in Section Four.

5.3 WATER BALANCE

5.3.1 PURPOSE

A water balance model was developed to evaluate the water management strategy during operations and closure. The model serves the following purposes:

- Identify the potential for developing water surplus and/or deficit conditions on the mine site during the life of the mine based on available climate information
- Estimate the magnitude of mine water discharge during operations for a probable range of climatic conditions
- Inform the development (by others) of operational discharge rules and Water Treatment Plant (WTP) design, if required

5.3.2 METHODOLOGY

The water balance model was developed in GoldSim 12.1, a dynamic probabilistic simulation model platform that models stored volume and flow based on user-defined inputs and assumptions. The model is used to provide estimates of monthly and annual water management requirements based on the following factors:

- Variable climate conditions
- Staged construction of the TMF throughout the operating life of the project

- Nominal mill throughput and estimated tailings dry density
- Preliminary site water management plan

The framework of the water balance model is based on the conceptual surface water management strategy described in detail in the previous subsections. Contact runoff will be pumped to the TMF supernatant pond from water management ponds around the site. Water collected in the TMF will be reclaimed to the Plant Site for use in mill operations and excess water will be discharged to the environment via a WTP, if required. The general arrangement and contributing catchment areas are shown on Figure 5.3 for the ultimate site general arrangement (Year 7). The operational and closure flow schematics for the water balance model are shown on Figure 5.4 and Figure 5.5, respectively.

The water balance model runs on a daily timestep over 15 years, beginning one year prior to operations (Year -1) and ending at the end of Year 14. Year -1 represents the initial construction of the project, Years one through seven represent operations and Years eight through 14 represent closure and post-closure periods of the project.

The following equation was used to calculate the surface runoff for each area.

Surface Runoff:

$$\text{Surface Runoff} = \text{Area} \times \text{Runoff Coefficient} \times \text{Monthly Precipitation}$$

Variable climate conditions were assessed by running the model under different sequences of the available historical rainfall and temperature data and generating stochastic results. There are 57 years of available data from Halifax Stanfield International Airport (1961 to 2017), which were taken from Environment Canada databases and are provided in Appendix D1. A single realization of the water balance model was run using each data year as a starting point. In total, 57 realizations were used to represent realistic climate sequences based on historical data. The annual rainfall for each realization was calculated using the following equation:

Stochastic Realization:

$$\text{Realization} = \text{Year 1} + \text{Realization} - 1$$

For each subsequent realization, the previous year's rainfall values were shifted to the last year and the next year's rainfall values were shifted to the first. This cycle repeats until the first year's rainfall value comes back to its original position. The results are presented as percentile statistics of the results of all realizations. These results represent the probable range of results based on historical climate data. Future climate change is not considered in the water balance model.

5.3.3 INPUTS

Time-series hydrometeorological inputs to the water balance model are presented in Appendix D1. Other inputs are based on design criteria described in other sections of this report and are summarized in Appendix D2. Estimates were used in areas for which measured data was unavailable. Inputs include the following:

- Hydrometeorological data from the Halifax Airport regional climate station (described in Section 2.5)
- Production schedule (consistent with the design basis described in Section 4.2)
- TMF storage volume (consistent with the design basis described in Section 4.2)
- Tailings properties (consistent with the design basis described in Section 4.2)

- Pond depth-area-capacity relationships are based on the design basis:
 - The TMF minimum volume is 270,000 m³ (one month of reclaim requirements)
 - The TMF maximum capacity is 800,000 m³
 - Water management pond capacities range from 15,000 m³ to 35,000 m³ and are based on three dimensional models of the ponds
- Catchment areas (shown on Figure 5.3)
- Mean receiving water seasonal flows (provided by Golder, shown on Table 5.1)

The mean receiving water seasonal flows were used to develop a hydrograph for discharge from the open pit during Post-Closure. The hydrograph of the receiving water is different from that of the site. Post-Closure discharge rates were selected to closely match the hydrograph of the receiving water in order to minimize the change in the receiving environment resulting from site discharge.

Table 5.1 Receiving Flow – Mean Conditions

Month	Receiving Flow (m ³ /mon) Mean Conditions	Percent of Total
Jan	14,740,000	11.7%
Feb	12,115,000	9.6%
Mar	21,981,000	17.5%
Apr	19,707,000	15.7%
May	7,095,419	5.6%
Jun	3,394,765	2.7%
Jul	2,161,803	1.7%
Aug	2,534,928	2.0%
Sep	2,821,452	2.2%
Oct	6,509,562	5.2%
Nov	15,190,000	12.1%
Dec	17,433,000	13.9%
TOTAL	125,683,929	100.0%

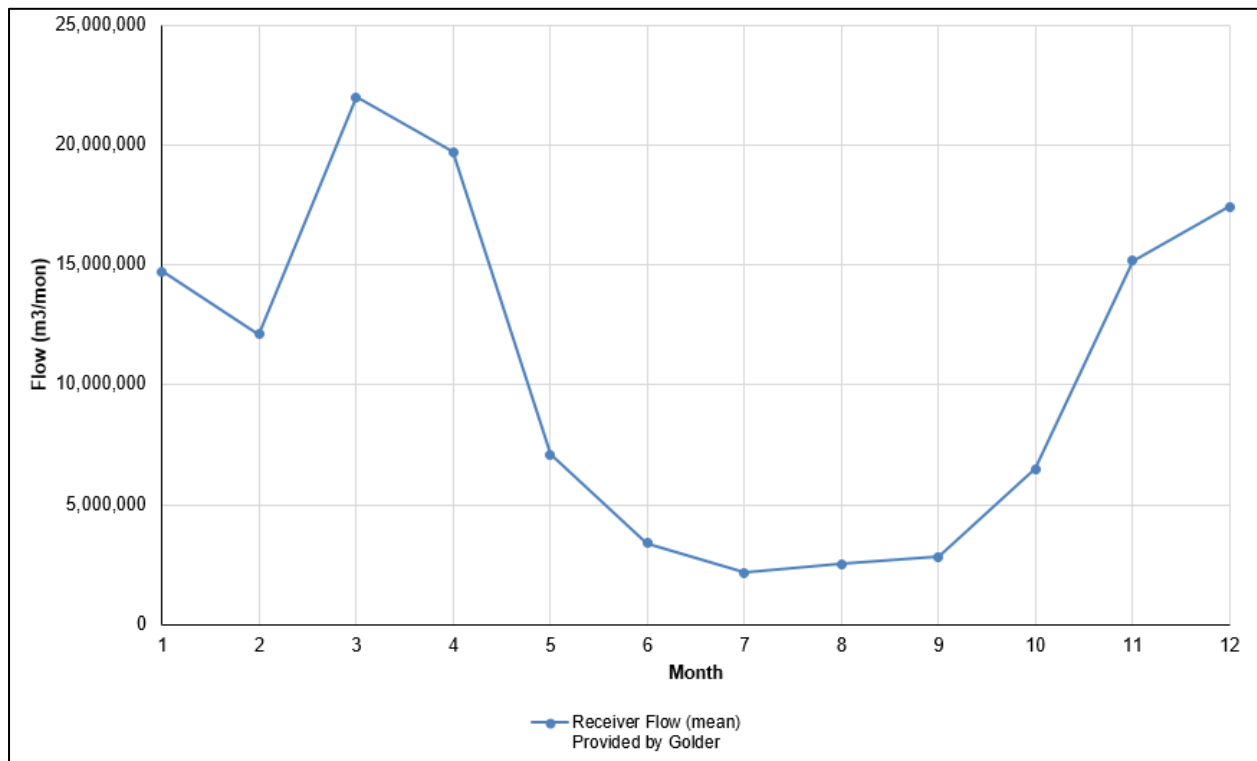
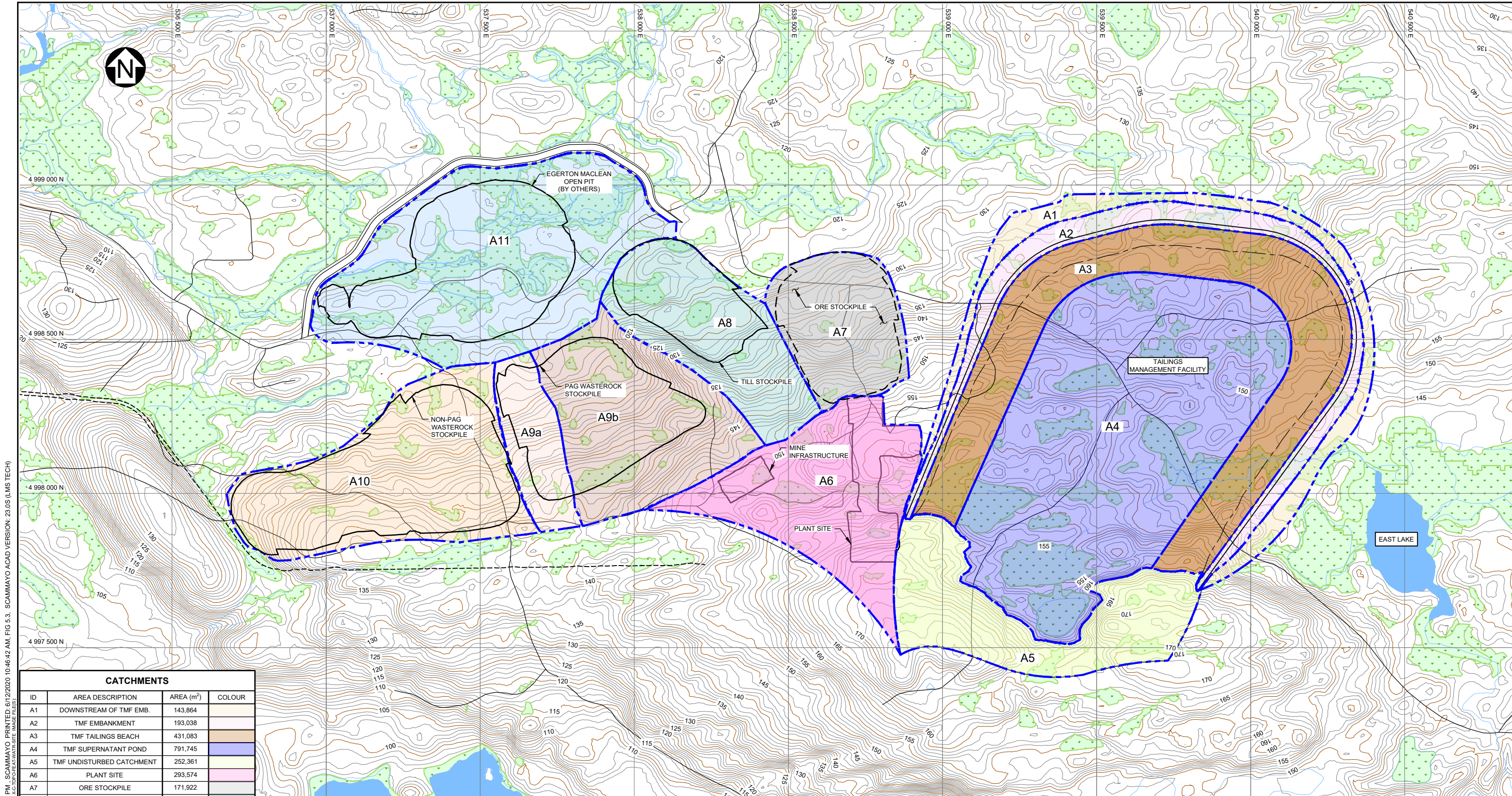

Figure 5.2 Receiving Flow – Mean Conditions



CATCHMENTS			
ID	AREA DESCRIPTION	AREA (m ²)	COLOUR
A1	DOWNSTREAM OF TMF EMB.	143,864	
A2	TMF EMBANKMENT	193,038	
A3	TMF TAILINGS BEACH	431,083	
A4	TMF SUPERNATANT POND	791,745	
A5	TMF UNDISTURBED CATCHMENT	252,361	
A6	PLANT SITE	293,574	
A7	ORE STOCKPILE	171,922	
A8	TILL AND TOPSOIL STOCKPILE	227,160	
A9a	PAG WASTE ROCK STOCKPILE	94,731	
A9b	PAG WASTE ROCK STOCKPILE	294,944	
A10	NON-PAG WASTE ROCK STOCKPILE	377,989	
A11	EGERTON MACLEAN OPEN PIT	495,562	

LEGEND:
 CATCHMENT BOUNDARY

- NOTES:**
- COORDINATE GRID IS NAD83, ZONE 20 T.
 - CONTOURS BASED ON 2014 LIDAR OBTAINED FROM GEONOVA, REPRODUCED AND DISTRIBUTED WITH THE PERMISSION OF INTERNAL SERVICES. CONTOURS HAVE BEEN PRODUCED BY KNIGHT PIESOLD LTD. AND INCLUDES DATA PROVIDED BY INTERNAL SERVICES. THE INCORPORATION OF DATA SOURCED FROM INTERNAL SERVICES WITHIN THIS PRODUCT SHALL NOT BE CONSTRUED AS CONSTITUTING AN ENDORSEMENT BY INTERNAL SERVICES OF OUR PRODUCT.
 - WETLAND AND WATER COURSE MAPPING PROVIDED BY McCALLUM ENVIRONMENTAL LTD. SEPTEMBER 06, 2018. DATA PROVIDED IN DRAFT WITH NO IMPLIED WARRANTIES AND SHALL BE CONSIDERED PRELIMINARY.
 - DIMENSIONS AND ELEVATIONS ARE IN METRES, UNLESS NOTED OTHERWISE.
 - LAYOUT IS FROM YEAR 7.

PLAN
SCALE A

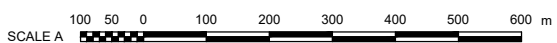

FOR INFORMATION ONLY

SAVED: M:\110100708\04\AAAcad\FIGS\B18_6\112020 3:45:19 PM - SCAMMAYO PRINTED: 6/12/2020 10:46:42 AM FIG 5.3 - SCAMMAYO ACAD VERSION: 23.05 (LMS TECH)

REV	DATE	DESCRIPTION	DESIGNED	DRAWN	REVIEWED
1	12JUN'20	ISSUED WITH REPORT	JEF	RMM/SC	DDF

ATLANTIC MINING NS CORP.	
FIFTEEN MILE STREAM PROJECT	
CONTRIBUTING CATCHMENT AREAS	
	P/ANO: VA101-708/4 REF NO: 2 FIGURE 5.3 REV 1

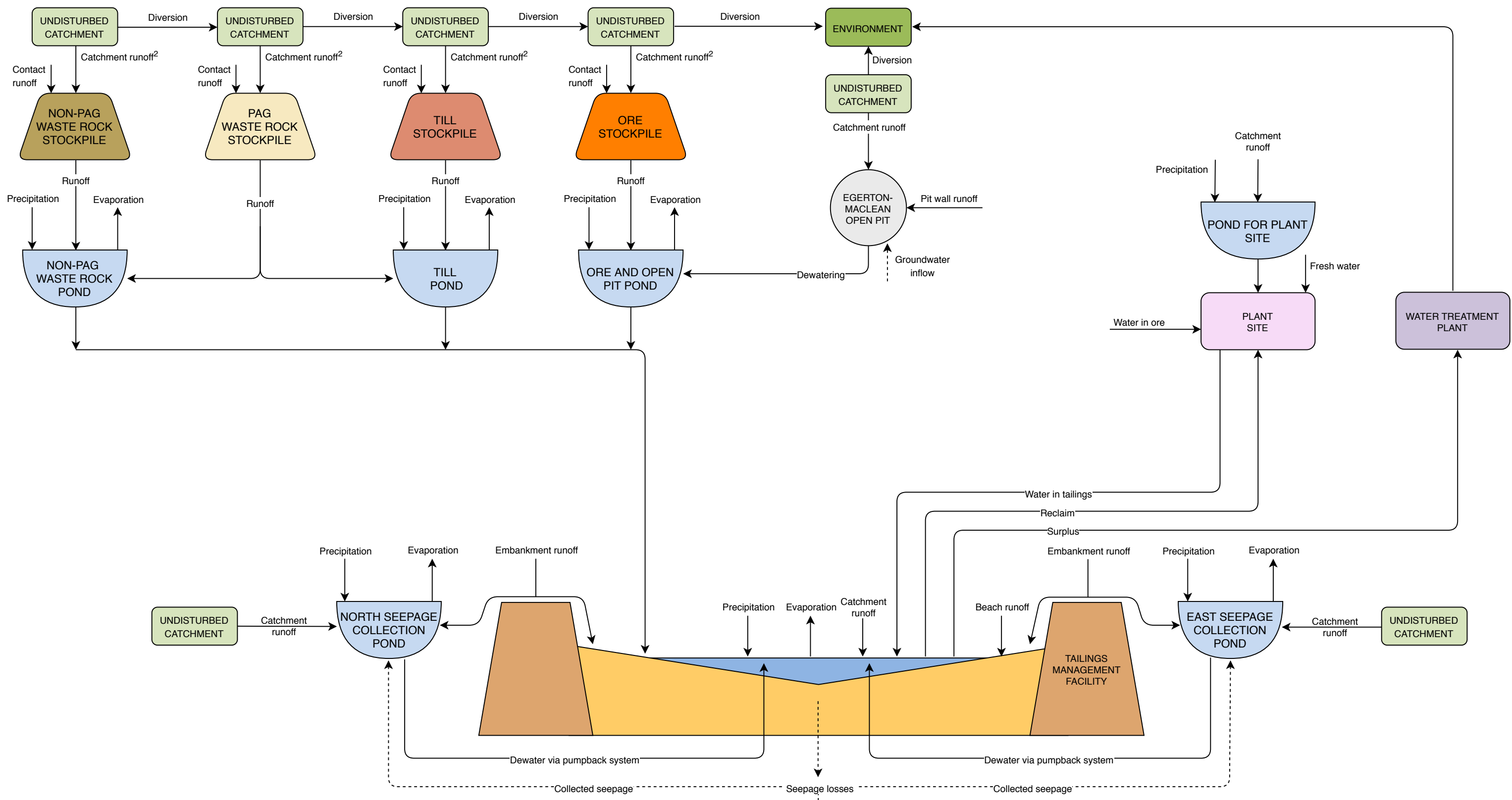

NOTES:
 1. FACILITIES ARE NOT DRAWN TO SCALE.
 2. CATCHMENT RUNOFF IS FROM THE STOCKPILE'S UNDISTURBED CATCHMENT AREA AND IS NOT DISTURBED.

ATLANTIC MINING NS CORP.	
FIFTEEN MILE STREAM PROJECT	
WATER BALANCE FLOW SCHEMATIC - OPERATIONAL YEAR -1 TO 7	
	P/A NO. VA101-00708/04
	REF. NO. 2
FIGURE 5.4	
	REV 1

1	12JUN20	ISSUED WITH REPORT	HW	CKJ	YEAR -1 TO 7	YEAR >= 8
REV	DATE	DESCRIPTION	PREPD	RWWD		

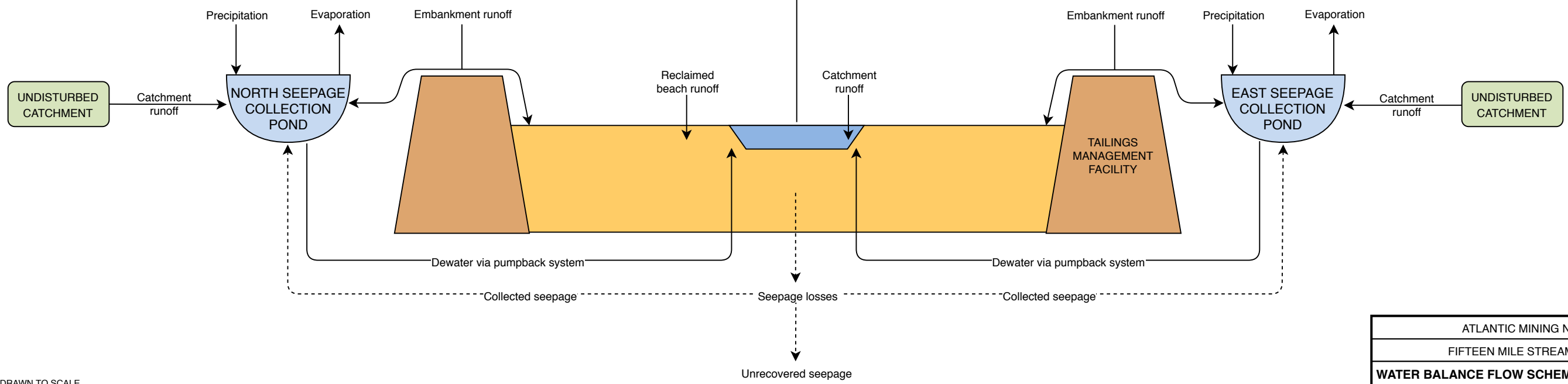
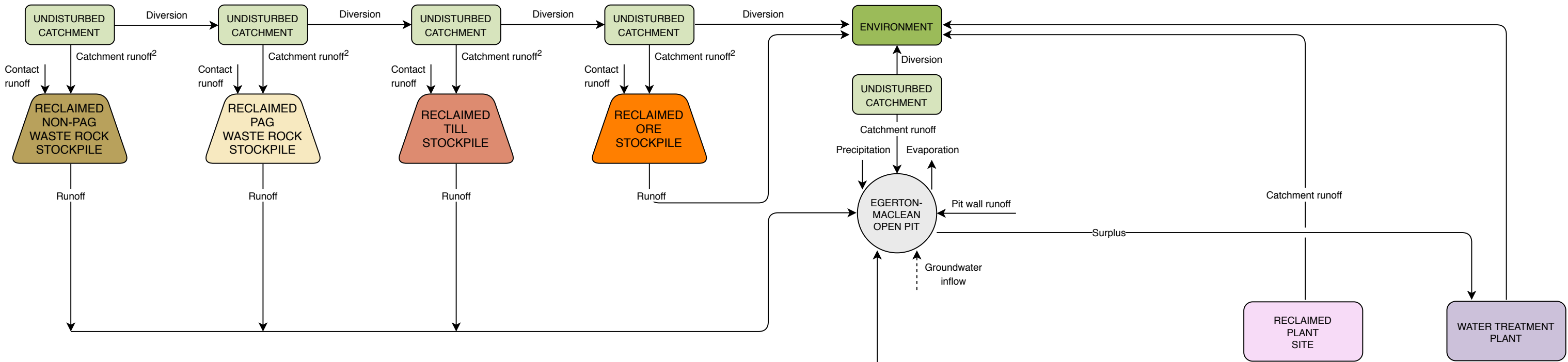

NOTES:
 1. FACILITIES ARE NOT DRAWN TO SCALE.
 2. CATCHMENT RUNOFF IS FROM THE STOCKPILE'S UNDISTURBED CATCHMENT AREA AND IS NOT DISTURBED.
 3. THE WATER BALANCE MODEL ASSUMES THE TMF SUMP CURRENTLY HAS NO VOLUME OR AREA. ALL RUNOFF IS SENT TO THE OPEN PIT.

ATLANTIC MINING NS CORP.	
FIFTEEN MILE STREAM PROJECT	
WATER BALANCE FLOW SCHEMATIC - CLOSURE AND POST-CLOSURE	
YEAR >= 8	
	P/A NO. VA101-00708/04
	REF. NO. 2
FIGURE 5.5	
	REV 1

REV	DATE	DESCRIPTION	PREPD	RWWD
1	12JUN20	ISSUED WITH REPORT	HW	CKJ

YEAR -1 TO 7 YEAR >= 8

5.3.4 ASSUMPTIONS

The accuracy of the predictions of the water balance model is limited by the availability and accuracy of input data. For the current scope of work, inputs for which measured data are not available are instead based on assumptions. These assumptions are indicated in the inputs table in Appendix D2. Further iterations of the water balance will be developed as more data become available.

For the following inputs, professional judgement was used to estimate preliminary values until additional laboratory data and analytical estimates are available:

- TMF seepage and void consolidation:
 - Seepage loss was represented in the water balance model by an outflow of 10 L/s with a 90% seepage recovery rate
 - Tailings void consolidation was assumed to be negligible
- Tailings specific gravity is assumed to be 2.79
- Snowfall and snowmelt assumptions are described in sub-section 5.3.4.2

The water balance for the Touquoy Project (Touquoy; Stantec, 2016) was used as an analog site to the FMS Project for input values, where appropriate. Touquoy is a similar project, also owned by Atlantic Mining NS Corp. The use of the following Touquoy water balance inputs in the FMS Project water balance is appropriate because of the similar design basis, proximity of the projects, and similar topography:

- Open Pit groundwater inflows: 500 m³/day
- Tailings production:
 - Slurry freshwater fraction: 5.8%
 - Water in ore: 2.5%
- Runoff coefficients (listed in Table 5.2)

Table 5.2 Surface Runoff Coefficients (Stantec, 2016)

Surface	Runoff Coefficient
Natural Ground	0.7
Disturbed Ground	0.85
Pond/Wet Tailings	1
Dry Tailings	0.5
Ditch	1
Open Pit	0.9

The estimated groundwater inflows from the Touquoy Mine have been included to provide an estimate for groundwater inflow and open pit dewatering rates through operations and closure, and are of a similar order of magnitude to the specific groundwater inflow estimates for each phase of project development subsequently estimated by Golder Associates (Golder, 2019).

5.3.4.1 TMF POND AND BEACH AREAS

The TMF pond and beach surface areas were applied as constant values. These areas are expected to fluctuate with the TMF pond volume, according to the stage storage curve. Further iterations of the water balance model could include calculations that use the stage storage curve as an input, if required. This refinement is not necessary for the purposes of the current scope.

5.3.4.2 SNOWFALL AND SNOWMELT ASSUMPTIONS

Precipitation was assigned as rainfall or snowfall based on the temperature time series. If the temperature for a given month was less than -2 °C (i.e. the minimum temperature for which precipitation is likely to fall as rain), then the precipitation for that month was assumed to fall as snow. If the temperature for a given month was greater than 2 °C (i.e. the maximum temperature for which precipitation is likely to fall as snow), then the precipitation for that month was assumed to fall as rain. If the temperature was between -2 °C and 2 °C, the amount of precipitation falling as snow was assumed to vary linearly with temperature.

Snowmelt quantity and timing were calculated as a function of the amount of snow accumulation and the monthly temperature. Sublimation was assumed negligible. An assumed snowmelt factor of 100 mm/°C was used to represent the rate at which the snowpack could melt. This assumption is based on a typical range between 50 mm/°C and 120 mm/°C at similar sites (KP, 2015).

5.3.5 WATER BALANCE RESULTS

Water balance results are presented in the subsections below as percentiles, which represent the range of probabilistic results based on the variable climate analysis. The 50th percentile results represent the median surplus that would result from all modelled realizations of historical climate data. The 5th percentile represents a smaller surplus that could occur if climate conditions fit within the 5th percentile dry climate conditions observed in the historical records. The 95th percentile represents wetter conditions, and 25th and 75th percentiles represent less severe dry and wet conditions, respectively.

Average climate case results for each facility are presented in Appendix D3 for operations and in Appendix D4 for closure and post-closure.

5.3.5.1 OPERATIONS

Table 5.3 and Figure 5.6 show the predicted annual surplus for the TMF, which represents the surplus of the entire site. The TMF surplus volumes are reported as annual volumes (i.e. not cumulative) and represent the surplus generated in the TMF each year in excess of the reclaim water requirements and other losses.

Table 5.3 TMF Annual Surplus - Operations

Year	Annual Surplus (m ³ /yr) - Percentile				
	5th	25th	50th	75th	95th
-1	2,055,000	2,527,000	2,792,000	3,260,000	3,982,000
1	2,825,000	3,290,000	3,619,000	4,222,000	4,862,000
2	2,807,000	3,311,000	3,634,000	4,210,000	4,858,000
3	2,813,000	3,322,000	3,644,000	4,233,000	4,875,000
4	2,811,000	3,282,000	3,605,000	4,232,000	4,887,000
5	2,739,000	3,272,000	3,594,000	4,227,000	4,886,000
6	2,773,000	3,289,000	3,612,000	4,215,000	4,870,000
7	2,920,000	3,386,000	3,715,000	4,352,000	5,010,000

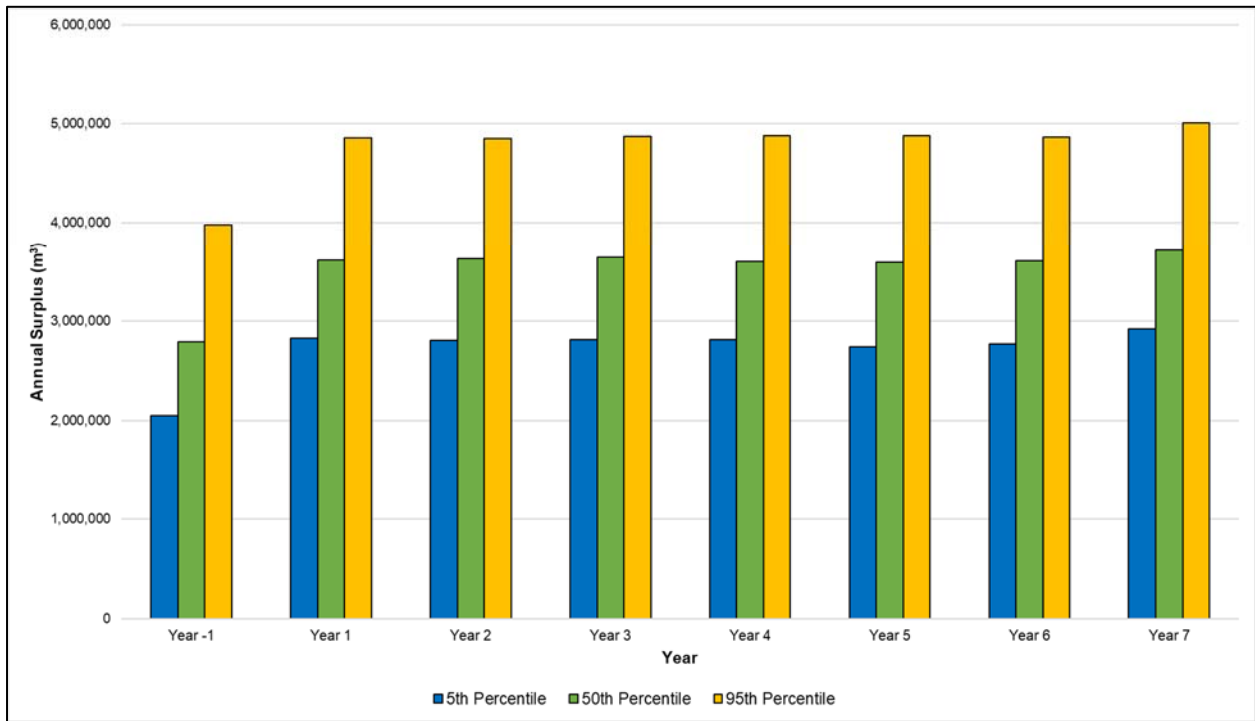

Figure 5.6 TMF Annual Surplus - Operations

5.3.5.2 CLOSURE AND POST-CLOSURE

Water from the open pit is discharged to the receiving environment during Post-Closure. The open pit discharge hydrograph has been modelled to closely match the hydrograph of the receiving water, which is different from that of the site.

The Post-Closure open pit has been modelled such that there is no discharge when the volume is below a threshold volume. When the open pit volume exceeds this threshold, the annual surplus is distributed over a monthly rate that results in a similar hydrograph to the receiving environment. The threshold volume of 10.3 Mm³ was calculated by trial and error, using different threshold volumes until the open pit volume no longer exceeded the maximum storage volume. Figure 5.7 shows the predicted stored volume in the open pit in comparison with the maximum volume of 13.5 Mm³. Results are shown for a range of variable climate conditions: 5th, 50th, and 95th percentiles.

Figure 5.8 shows the open pit discharge rates, which follows a similar hydrograph to the receiving flow. It should be noted that the open pit discharge pattern has been modelled to only match the mean receiving flows. Wet and dry conditions for the receiving flow were not provided. If variations in climate result in different hydrographs in the receiving environment, the discharge hydrograph from the open pit may vary from that of the receiving environment.

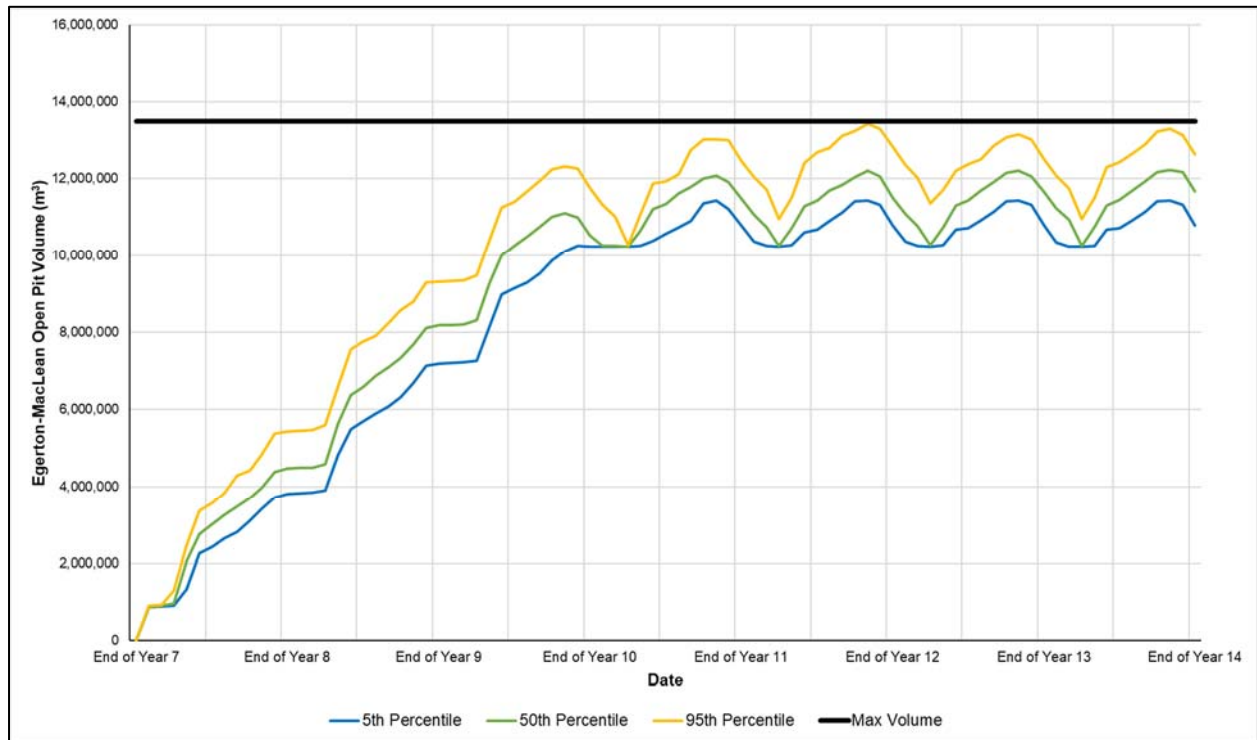

NOTES:

1. OPEN PIT VOLUME IS 0 M³ FROM YEAR -1 TO END OF YEAR 7.
2. OPEN PIT MAX VOLUME IS 13,490,000 M³.
3. OPEN PIT MIN VOLUME MAINTAINED IS 10,250,000 M³.

Figure 5.7 Open Pit Volume – Closure and Post-Closure

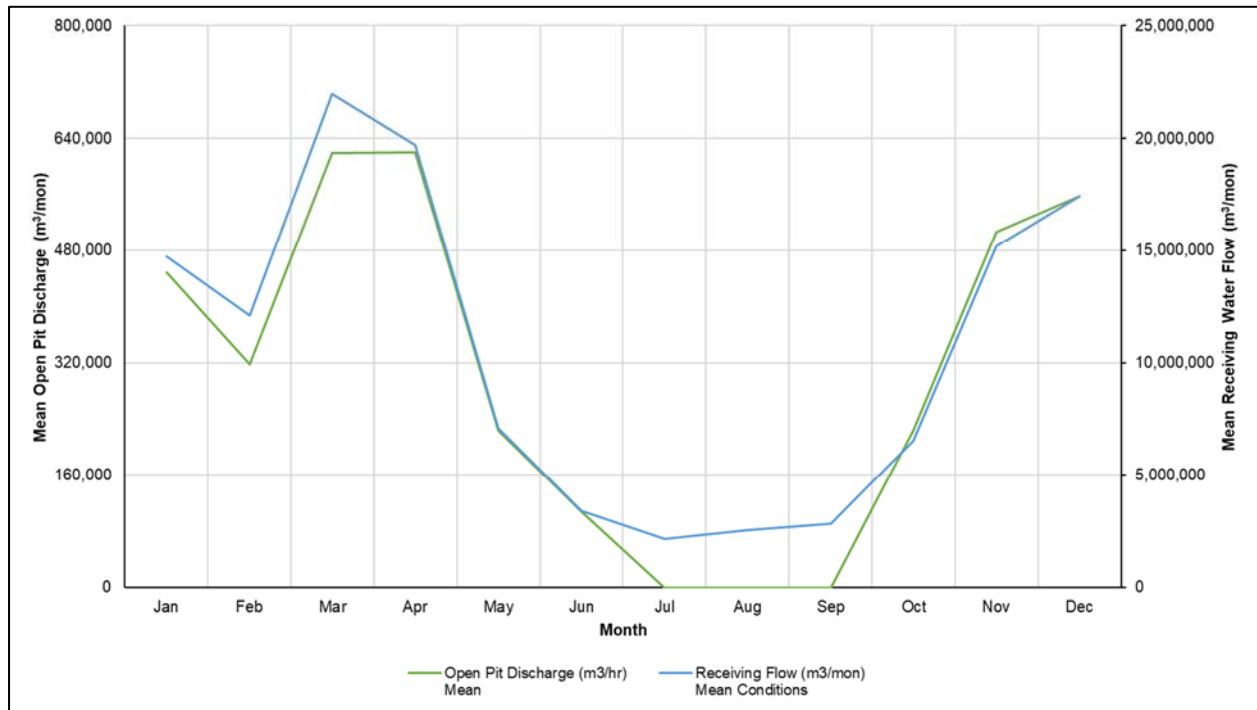
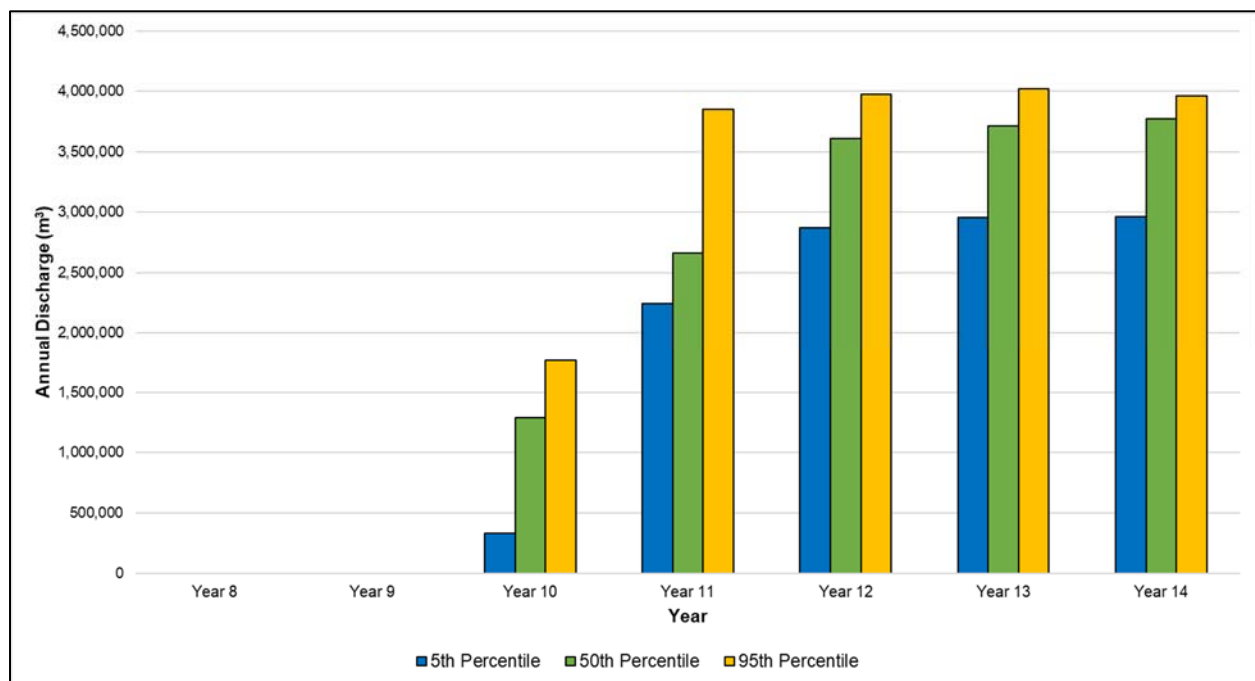

Figure 5.8 Open Pit Monthly Discharge Rates and Receiving Flow Under Average Climate Conditions

The open pit discharge during post-closure is reported in Table 5.4 and on Figure 5.9 as annual volumes (i.e. not cumulative over multiple years) as statistics of the variable climate analysis. The median climate case annual discharge is 3.8 Mm³ and the 95th percentile annual discharge is 4.0 Mm³. The median and 95th percentile case values are similar because the open pit discharge is limited by the mean conditions of the receiving environment. The 95th percentile case effectively represents 95th percentile wet conditions on site and mean conditions in the receiving environment. The water balance will be refined as the design of the FMS Project is advanced. Refinements may include more detail considering the variable climate effects in the receiving environment.

Table 5.4 Open Pit Annual Surplus – Post-Closure

Year	Annual Surplus (m ³ /yr) - Percentile				
	5th	25th	50th	75th	95th
8	0	0	0	0	0
9	0	0	0	0	0
10	333,000	907,000	1,285,000	1,523,000	1,767,000
11	2,245,000	2,327,000	2,658,000	2,996,000	3,854,000
12	2,872,000	3,268,000	3,606,000	3,952,000	3,974,000
13	2,955,000	3,340,000	3,716,000	3,940,000	4,020,000
14	2,965,000	3,342,000	3,774,000	3,940,000	3,961,000



NOTES:

1. OPEN PIT ANNUAL DISCHARGE HAS ONLY BEEN MODELLED TO MATCH THE MEAN CONDITIONS OF THE RECEIVING FLOW.

Figure 5.9 Open Pit Annual Surplus – Post-Closure

6.0 CONSTRUCTION

6.1 GENERAL

Earthworks construction activities will include foundation preparation, embankment fill zone placement, till liner construction, and installation of instrumentation. Additional activities will include installation of pumps and pipelines.

The Stage One TMF Embankment will be constructed with NPAG waste rock from pre-stripping activities at the open pit and select till and overburden from local borrow sources. Site haul roads and access roads will be constructed prior to TMF embankment construction to provide access to the TMF.

During construction it is anticipated that a contractor would be responsible for foundation preparation, embankment fill placement, liner installation, and installation of instrumentation, sumps, pumps, and pipelines.

It is anticipated that construction of the tailings and water management facilities will take place 12 months prior to commencement of milling (i.e. in Year -1). Diversion channels will be constructed first to aid in water management for construction. Completion of the TMF embankment and liner system will be prioritized to allow for storage of water required for mill start-up.

6.2 SITE ESTABLISHMENT

Site establishment will consist of the activities required prior to beginning construction of the Stage One TMF Embankment.

Pre-construction activities (construction Phase I) will including the following works:

- Logging of impoundment (as required)
- Establishing an access road sufficient for the contractor's equipment
- Establishing any temporary camps, maintenance shops, or other infrastructure that the contractor may require
- Preparing suitable laydown areas for equipment and cleared timber
- Preparation for best management practices for sediment control and erosion protection (sediment control ponds, silt fences, straw bales)

Phase II of construction involves the preparation of water management structures, including the following activities:

- Excavation and armoring of the non-contact water diversion channels
- Pioneer haul road for access to the open pit
- Construction of water management ponds and pump back systems downstream of the embankment

Phase III of construction involves the excavation and preparation of the Stage 1 TMF Embankment footprint and TMF basin, including the following works:

- Clearing and grubbing of the starter embankment footprint and upstream liner footprint
- Excavation of unsuitable overburden material for the Stage One embankment footprint (areas outside of the diversion channels) and the upstream liner

- Installation and operation of construction dewatering equipment
- Topsoil and overburden stockpile development in close proximity to the embankment
- Commence construction of seepage collection ditches

Phase IV of construction relates to the excavation of construction materials, and construction of the Stage One TMF Embankment, TMF Basin Liner, Seloam Brook Diversion, and installation of tailings distribution, reclaim water, and surplus water management systems.

Construction activities for Phase IV include the following:

- Construction of Seloam Brook Diversion Berm
- Armouring of Seloam Brook Diversion Channel (where necessary)
- Pre-stripping of till and NPAG waste rock from the open pit to provide construction materials for the Stage 1 TMF Embankment
- Excavation of the till borrow sources for the Stage 1 TMF Embankment upstream face and the upstream liner system for the TMF basin
- Construction of the Stage 1 TMF Embankment shell
- Construction of upstream liner system
- Establishment of site water management systems
- Installation of tailings and reclaim pipelines, pump stations, power supply and controls
- Demobilization of contractor fleet used for the Stage 1 TMF Embankment construction
- Impounding runoff water behind the Stage 1 TMF Embankment for mill start-up

6.3 WATER MANAGEMENT

Water management during the construction phase will mostly involve erosion and sediment control for excavations and construction areas, construction dewatering, and temporary silt fencing/diversions when establishing permanent water management. Specific water management activities for the construction phase include:

- Construction of temporary diversions in the Seloam Brook drainage area to allow for construction of the Seloam Brook Diversion Berm
- Excavation, temporary diversion structures, construction dewatering and other erosion and sediment control measures (i.e. silt fencing, sandbags, etc.) for all construction areas
- Water from construction dewatering will be directed to established ponds throughout the construction phase to allow for monitoring of water quality and treatment, if required
- Construction and pit dewatering during pre-stripping of the open pit
- Pre-stripping of the pit to not commence until Seloam Brook Diversion Berm has been established to allow for reduced surface runoff into the construction areas

6.4 WATER MANAGEMENT MONITORING

During construction, the emphasis of monitoring will be on the implementation and success of mitigation at construction areas. Toward the end of construction, operation phase monitoring activities will be implemented, and monitoring will shift to include the relevant aspects of operations. This will include the installation of operation phase water management facilities, milling, pre-stripping, and mining of the open pit, and the development of waste rock stockpiles.

7.0 OPERATIONS AND MONITORING

7.1 GENERAL

Proper operation, monitoring and record keeping are a critical part of all tailings and water management facilities. An Operations, Maintenance and Surveillance (OMS) Manual will be prepared for the tailings and water management systems as part of the detailed design of the TMF. This document will be reviewed and updated on an ongoing basis. The OMS Manual will outline regular monitoring, inspection, and reporting requirements. The OMS manual should be referenced for all operations and monitoring activities relating to the TMF and ancillary water control structures.

Emergency response measures in the event of upset operating conditions will be addressed in the Tailings Emergency Preparedness and Response Plan (EPRP).

7.2 TMF MONITORING

Monitoring will be required as part of the ongoing operation of the facilities. Monitoring of the TMF and ancillary works will provide important input for performance evaluation and refinement of operating practices. Complete details of the monitoring program will be included in the OMS Manual that will be prepared for the TMF. Monitoring will be conducted throughout the life of the facility including construction, operation, decommissioning and post-closure.

The proposed monitoring falls into three basic types as follows:

- General monitoring includes items such as:
 - Tailings deposition locations
 - Checks on pipe joints and pipe integrity
 - Performance of pumps and valves
 - Embankment freeboard
 - Embankment spillway performance
 - Non-Contact water diversion channel performance and integrity
 - Water levels in ponds, etc.

Regular inspections will help identify any areas of concern that may require maintenance or more detailed evaluation. General monitoring will largely be undertaken through visual inspections carried out by designated personnel. Detailed inspection checklists, action sheets, and recording and reporting procedures will be developed for daily, weekly, and monthly inspections.

- Performance Monitoring includes items such as:
 - Tailings performance monitoring
 - Tailings solids content
 - Tailings discharge rates
 - Tailings slurry volumes
 - Tailings degree of saturation
 - Tailings beach slope
 - Tailings level and density surveys
 - Supernatant pond monitoring

- Supernatant pond volume
- Operational pond levels
- Water flow measurements
- TMF embankment performance monitoring
 - Analyzing settlement gauge data
 - Analyzing vibrating wire piezometer data
 - Monitoring movement monuments
 - Completing embankment surveys
- Site Water Management Monitoring includes items such as:
 - Sediment and erosion monitoring
 - Sediment built-up
 - Structural/physical integrity of control measures
 - Wear and tear of control measures
 - Water consumption
 - Operational water management monitoring
 - Water consumption rates
 - Operational pond levels in all water management ponds
 - Integrity of diversion and collection ditches
 - Integrity of water management structures

The monitoring program will be used to verify the performance of the facility, to refine future embankment raise levels, and to demonstrate that the project is meeting all its commitments related to operating a safe and secure facility. Monitoring of the waste and water management facilities will also provide performance evaluation information that will help refine operating practices.

8.0 RECLAMATION AND CLOSURE

8.1 RECLAMATION OBJECTIVES

Reclamation and closure will involve an active decommissioning and closure period in which all mine components will be prepared for permanent closure, and a post-closure period. Closure will be completed in a manner that will satisfy physical, chemical, and biological stability, as well as follow the applicable regulatory framework.

Closure and rehabilitation activities will be carried out progressively during the Operations Phase (where practicable) and at the end of economically viable mining. Closure and rehabilitation activities will be conducted in accordance with international closure standards. The primary objectives of reclamation and closure for the FMS Project are that:

- Dust is not emitted from the FMS Project site as a result of moisture loss from the TMF surface or surface of the Waste Rock Stockpiles
- Runoff does not affect surface water or groundwater quality
- The TMF embankment and stockpile slopes remain stable
- The stored tailings and waste rock remain physically and chemically stable

The primary objective of the closure and reclamation initiatives will be to return the project site to a self-sustaining condition with pre-mining usage and capability. The reclaimed facilities will be required to maintain long-term geochemical and physical stability, protect the downstream environment, and shed surface water. Activities that will be carried out during operations and at closure to achieve these objectives are discussed below.

Surface facilities will be removed in stages and full reclamation of the TMF will be initiated upon mine closure. General aspects of closure will include:

- Selective discharge of tailings around the facility prior to closure to establish a final tailings beach that will facilitate surface water drainage and reclamation
- Removal of surface water ponds and drainage of supernatant pond
- Dismantling and removal of the tailings and reclaim delivery systems and all pipelines, structures and equipment not required beyond mine closure
- Capping of the TMF using combined rock and soil cover that will shed runoff to a permanent spillway
- Capping of the PAG Waste Rock Stockpile with a soil cover to facilitate runoff from the surface of the stockpile and inhibit the infiltration of precipitation
- Establishment of a permanent spillway at the TMF to allow for the passive drainage of runoff from the facility
- Removal of the seepage collection pump-back systems at such time that suitable water quality for direct release is achieved
- Removal and re-grading of all access roads, ponds, ditches and borrow areas not required beyond mine closure
- Long-term stabilization and vegetation of all exposed erodible materials

The preliminary concept for TMF reclamation is shown on Figure 8.1.

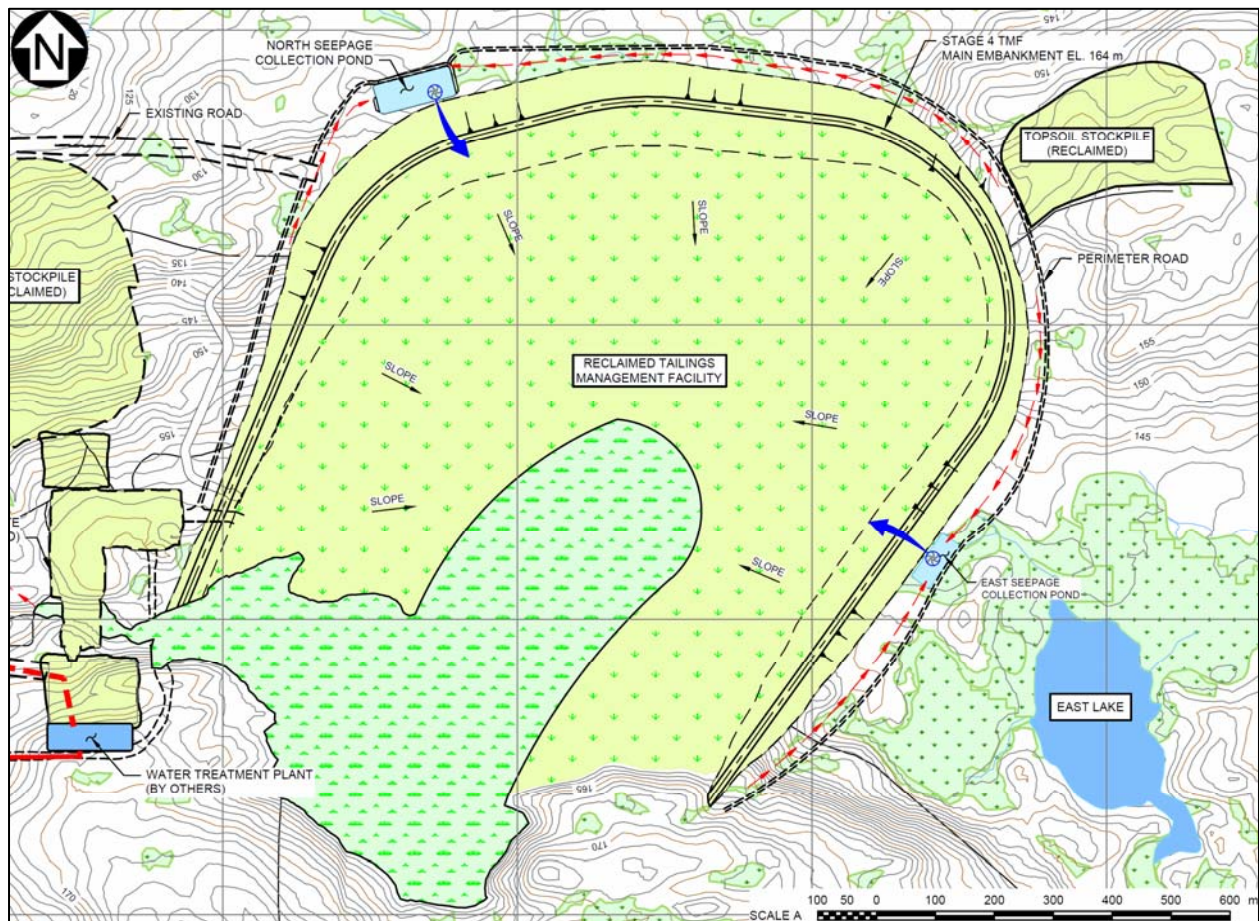

Figure 8.1 Reclaimed TMF General Arrangement

The groundwater monitoring wells, and all other geotechnical instrumentation will be retained for use as long-term dam safety monitoring devices. Post-closure requirements will also include annual inspection of the facility and ongoing evaluation of water quality, flow rates and instrumentation records to confirm design assumptions and performance for closure.

Industry standard reclamation methods will be employed to decommission the remainder of the disturbed areas. Hazardous materials will be collected for offsite disposal including hazardous components of vehicles and equipment (i.e., fuel tanks, gear boxes and glycol-based coolant, etc.). Buildings and equipment stripped of hazardous components will be demolished and disposed in an approved landfill, offsite. Culverts will be removed from roads and the natural drainage restored, but the roads will otherwise remain intact.

Once all buildings, facilities and equipment have been removed, the footprints (whether bedrock foundations or prepared pads) will be re-contoured to allow for restoration of natural drainage to the receiving environment.

8.2 CLOSURE WATER MANAGEMENT

At closure, a flow path for runoff from the surface of the reclaimed TMF to the open pit will be established through grading of the TMF closure cover, a breach in the southwestern abutment of the TMF, and a diversion/collection channel to convey runoff to the open pit.

Water will accumulate in the open pit until it fills, at which point it will be discharged to the environment, via a WTP, if necessary.

Closure monitoring at receiving waters will be measured against water quality objectives. The following items are planned for monitoring during closure:

- Regular inspections to confirm that closure activities are being undertaken as identified in the final approved mine closure and reclamation plan
- Construction-type monitoring is undertaken during decommissioning activities
- TMF water quality monitoring until water quality guidelines are met

Post-closure monitoring is expected to be required after completion of closure activities. Post-closure monitoring is expected to include:

- Water quality sampling at mine contact water discharge locations in accordance with water quality objectives
- Final environmental effects monitoring studies in accordance with water quality objectives needed to obtain status as a recognized closed mine from the relevant federal and provincial regulatory authorities

8.3 ON-GOING MONITORING REQUIREMENTS

The water management ponds and recycle pumps being used to collect seepage and embankment runoff will be retained until water quality monitoring results indicate that any seepage from the TMF is of suitable quality for direct release to downstream waters. The groundwater monitoring wells, and all other geotechnical instrumentation will be retained for long-term monitoring.

Post-closure requirements will also include an annual inspection of the TMF and an ongoing evaluation of water quality, flow rates, and instrumentation records to confirm the design assumptions for closure.

9.0 SUMMARY

Designs have been prepared for tailings and water management facilities at the FMS Project to support the Environmental Impact Statement (EIS) submission. The designs provide permanent and secure storage of tailings, temporary storage during operations for process and contact water, and control of non-contact surface water across the project site.

The project involves a conventional truck-shovel open pit mine and a 5,500 tpd processing plant. Ore will be processed on site at a nominal production rate of approximately 5,500 tpd to produce gold concentrate for shipment to Touquoy for final leaching. The mining and processing of ore will produce approximately 13.4 million tonnes (Mt) of tailings and 24.4 Mt of waste rock over an operating mine life of approximately seven years. The tailings will be conveyed to the TMF from the mill via an overland pipeline.

The principle design objective of the TMF is to protect the environment during the operations and throughout the closure stage of the project and to achieve effective surface reclamation at mine closure. The design of the TMF has considered the following requirements:

- Permanent, secure, and total confinement of all tailings solids within an engineered facility
- Control, collection, and removal of free draining liquids from the tailings during operations, for recycling as process water to the maximum practical extent
- Inclusion of monitoring features for all aspects of the facility to verify that performance goals are achieved, and design criteria are met

The TMF has been designed to store 10.3 million cubic metres (Mm³) of tailings at a final average settled density of 1.3 t/m³, with additional capacity for a supernatant pond as a source of process water, and contingency storage for an Environmental Design Flood (EDF) equivalent to the total precipitation from a 1-in-200 year 24-hr precipitation event in addition to the estimated maximum mean monthly precipitation over the entire TMF catchment. Flood events exceeding the EDF will be safely passed from the facility via an Emergency Discharge Spillway located at the southwestern abutment of the TMF embankment. An alternative to the Emergency Discharge Spillway is to allow for a larger TMF embankment with additional contingency storage to store inflows from flood events up to the Inflow Design Flood (IDF).

The embankment will be constructed with a crest width of approximately 15 m to allow for single lane haul truck traffic within safety berms and pipeline routes. The embankment will be primarily constructed with pit run waste rock. Filter and Transition Zones consisting of filter sand and drain gravel will be placed on the upstream face of the embankment. A liner material consisting of compacted, low-permeability till will be constructed on top of the filter zone material. Instrumentation will be installed in the TMF embankment and underlying foundations and monitored during all phases of the project. Monitoring data will be used to assess performance and to identify any conditions that differ from those assumed during design and analysis.

The TMF embankment has been assigned a dam classification of HIGH following CDA guidelines. The dam classification is used to determine the minimum target levels for the IDF and EDGM for the TMF embankment. The following minimum target design flood and earthquake levels were adopted from the CDA guidelines (CDA, 2013 and 2014) for a HIGH dam hazard classification for the construction and operations phases of the project:

- IDF: 1/3 between the 1/1,000-year return period event and the PMF

- EDGM: the 1/2,475-year return period seismic event

Collection ditches along the perimeter road around the toe of the TMF embankment will collect runoff from the embankment and seepage through the embankment and foundation. The collection ditches will convey these flows to the two seepage collection ponds. Flows collected in the ponds (including precipitation on the surface of the pond) will be pumped back to the TMF supernatant pond.

Non-contact water will be diverted around site facilities to the maximum practicable extent to minimize the impact to local watercourses and the unnecessary collection of fresh water. Contact water from site facilities and stockpiles will be collected in a system of ditches that convey collected flows to water management ponds. Water collected in the water management ponds will be pumped to the TMF supernatant pond.

Seloam Brook will be diverted through the construction of a raised perimeter berm along the east, north and west of the open pit. The berm will divert flows from Seloam Brook around the open pit on the north side of the pit. The currently proposed berm alignment and crest elevation sufficiently realigns and diverts flows from a 1-in-200 year, 24-hour precipitation event away from the mine working areas.

The SWMS allows for the removal of excess water from the TMF supernatant pond during operations to maintain target operating pond volumes, tailings beach length, and minimum freeboard requirements. Surplus water will be removed by pumping water to a WTP located near the Plant Site, if required to meet discharge criteria. Water will be discharged to Anti-Dam Flowage via a gravity discharge pipeline.

The water management plan forms the basis of the site wide water balance model, which has been developed on a monthly basis and considers a range of climatic conditions consistent with historic variability in the project area. The primary goal of the water balance model is to estimate the anticipated volume of surplus water that must be released from the mine site on an annual basis to manage the inventory of water stored in the TMF within a target range consistent with the design basis of the impoundment.

10.0 REFERENCES

- Adams, J. and Halchuk, S., 2003. Fourth generation seismic hazard maps of Canada: Values for over 650 Canadian localities intended for the 2005 National Building Code of Canada. Geological Survey of Canada, Open File 4459.
- Adams, J., Halchuk, S., Allen, T. & Rogers, G., 2015. Canada's 5th Generation seismic hazard model, as prepared for the 2015 National Building Code of Canada. Canadian Conference on Earthquake Engineering, Victoria, Canada, Paper 93775.
- Atkinson, G.M. & Adams, J., 2013. Ground motion prediction equations for application to the 2015 Canadian national seismic hazard maps. Canadian Journal of Civil Engineering, Vol.40, No. 10, p988-998.
- Atlantic Gold Corp., 2018. Moose River Consolidated Project, Nova Scotia Canada – NI 43-101 Technical Report on Moose River Consolidated Phase 1 and Phase 2 Expansion. Effective date January 24, 2018.
- Brooks, R.R., Chatterjee, A.K., Smith, P.K., Ryan, D.E., Zhang, H.F., 1981. The distribution of gold in rocks and minerals of the Meguma Group of Nova Scotia, Canada. Chemical Geology, issue 35, pp 87-95.
- Canadian Dam Association (CDA), 2013. 2007 Dam Safety Guidelines – 2013 Revision.
- Canadian Dam Association (CDA), 2014. Technical Bulletin: Application of Dam Safety Guidelines to Mining Dams.
- Cassidy, J.F., Rogers, G.C., Lamontagne, M., Halchuk, S., and Adams, J., 2010. Canada's Earthquakes: The Good, the Bad and the Ugly. GeoScience Canada, 2010, Volume 37 Number 1.
- Faribault, E.R., 1903. Deep Gold Mining. The Nova Scotian, pp 22-28.
- Faribault, E.R., 1913. The gold-bearing series of Nova Scotia. Guidebook No.1 – Excursion in Eastern Quebec and the Maritime Provinces – Part 1, pp 158-192. Geological Survey of Canada.
- FSSI Consultants, 2015. Technical Report of the Fifteen Mile Stream Project, Halifax County, Nova Scotia. Report prepared on behalf of Atlantic Gold Corp. Effective date February 18, 2015.
- GEOSLOPE International Ltd., 2018. GeoStudio 2018 R2. Geotechnical Analysis Software. Version 9.1.0.16306. Calgary, AB.
- Golder Associates, 2019. Fifteen Mile Stream Gold Project, Hydrogeological Modeling Assessment (DRAFT). Document Number 1895674-024-R-RevA.
- Halchuk, S.C., Adams, J.E., and Allen, T.I., 2015. Fifth Generation Seismic Hazard Model for Canada: Grid values of mean hazard to be used with the 2015 National Building Code of Canada. Geological Survey of Canada, Open File 7893.
- Knight Piésold Ltd. (KP), 2015. Climate Variability for Water Balances Produced in GoldSim. Ref. No. VA108-231/6-A.01. January 12, 2015.
- Knight Piésold Ltd. (KP), 2017. Fifteen Mile Stream Project – TSF Options Development. Letter prepared for Atlantic Gold Corp. August 31, 2017. Ref. No. VA17-01492.

- Knight Piésold Ltd. (KP), 2018a. Fifteen Mile Stream – Desktop Terrain Analysis Study. Letter prepared for Atlantic Gold Corp. March 5, 2018. Ref. No. VA17-01808.
- Knight Piésold Ltd. (KP), 2018b. Moose River Consolidated Phase II – Preliminary Engineering Hydrometeorology Report. Report prepared for Atlantic Gold Corp. Rev.0. September 10, 2018. Ref. No. VA101-708/4-1.
- Knight Piésold Ltd. (KP), 2018c. Cochrane Hill and Fifteen Mile Stream Projects – Seismic Design Parameters. Memorandum prepared for Atlantic Gold Corp. March 5, 2018. Ref. No. VA18-00160.
- Knight Piésold Ltd. (KP), 2019. Moose River Consolidated Phase II – Updated Seismic Design Parameters. Memorandum prepared for Atlantic Gold Corp. April 5, 2019. Ref. No. VA18-02372.
- Leps, T.M., 1970. Review of the shearing strength of rockfill. Journal of Soil Mechanics and Foundation Division, ASCE, Vol.96, No. SM4, Proc. Paper 7394, July 1970, p1159-1170.
- Melo, C. and Sharma, S., 2004. Seismic Coefficients for Pseudostatic Slope Analysis. Proceedings of the 13th World Conference on Earthquake Engineering. Vancouver, BC. August 2004.
- McNulty, L., 1983. The Mineralogy of the Fifteen Mile Stream Gold District. BSc Submission at Dalhousie University, Halifax, NS. May 1983.
- Mining Association of Canada (MAC), 2017. A Guide to the Management of Tailings Facilities. 3rd Edition. Ottawa, ON.
- National Research Council Canada (NRCC), 2015. National Building Code of Canada.
- Natural Resources Canada (NRCan), 2015. 2015 National Building Code of Canada seismic hazard calculator. http://www.earthquakescanada.nrcan.gc.ca/hazard-alea/interpolat/index_2015-en.php.
- Natural Resources Canada (NRCan), 2016. Earthquake Zones in Eastern Canada. <http://www.earthquakescanada.nrcan.gc.ca/zones/eastcan-en.php>.
- Nova Scotia Department of Natural Resources (DNR), 2005. Ecological Land Classification for Nova Scotia. Revised Edition 2005. Nova Scotia, Canada.
- Schenk, P.A., 1970. Regional variation of the flysch-like Meguma Group (Lower Paleozoic) of Nova Scotia, compared to recent sedimentation off the Scotian Shelf. Geological Association of Canada Special Paper, issue 7, pp 127-153.
- Smith, P.K., 1982. Geology of the Cochrane Hill Gold Deposit, Guysborough County, Nova Scotia. In: Mines and Minerals Branch, Report of Activities 1982, report 83-1, pp 225-256.
- Smith, P.K. 1983. Geology and Lithogeochemistry of the Cochrane Hill Gold Deposit - An indication of metalliferous source beds. In: Mines and Minerals Branch, Report of Activities 1983, report 84-1, pp 203-214.
- Stantec Consulting Ltd. (Stantec), 2016. Water Balance Report, Project No. 121619250. November 25, 2016.
- Thornthwaite, C.W., 1948. An Approach Toward a Rational Classification of Climate. Geographical Review (American Geographical Society) Issue 38 (1): pp. 55-94.

11.0 CERTIFICATION

This report was prepared and reviewed by the undersigned.

Prepared:

Jim Fogarty, P.Eng.
Senior Engineer



Reviewed:

Daniel Fontaine, P.Eng.
Specialist Engineer | Associate

This report was prepared by Knight Piésold Ltd. for the account of Atlantic Mining NS Corp. Report content reflects Knight Piésold's best judgement based on the information available at the time of preparation. Any use a third party makes of this report, or any reliance on or decisions made based on it is the responsibility of such third parties. Knight Piésold Ltd. accepts no responsibility for damages, if any, suffered by any third party as a result of decisions made or actions based on this report. Any reproductions of this report are uncontrolled and might not be the most recent revision.

Approval that this document adheres to the Knight Piésold Quality System:

DDF

APPENDIX A

Design Figures

(Figures A.1 to A.11)

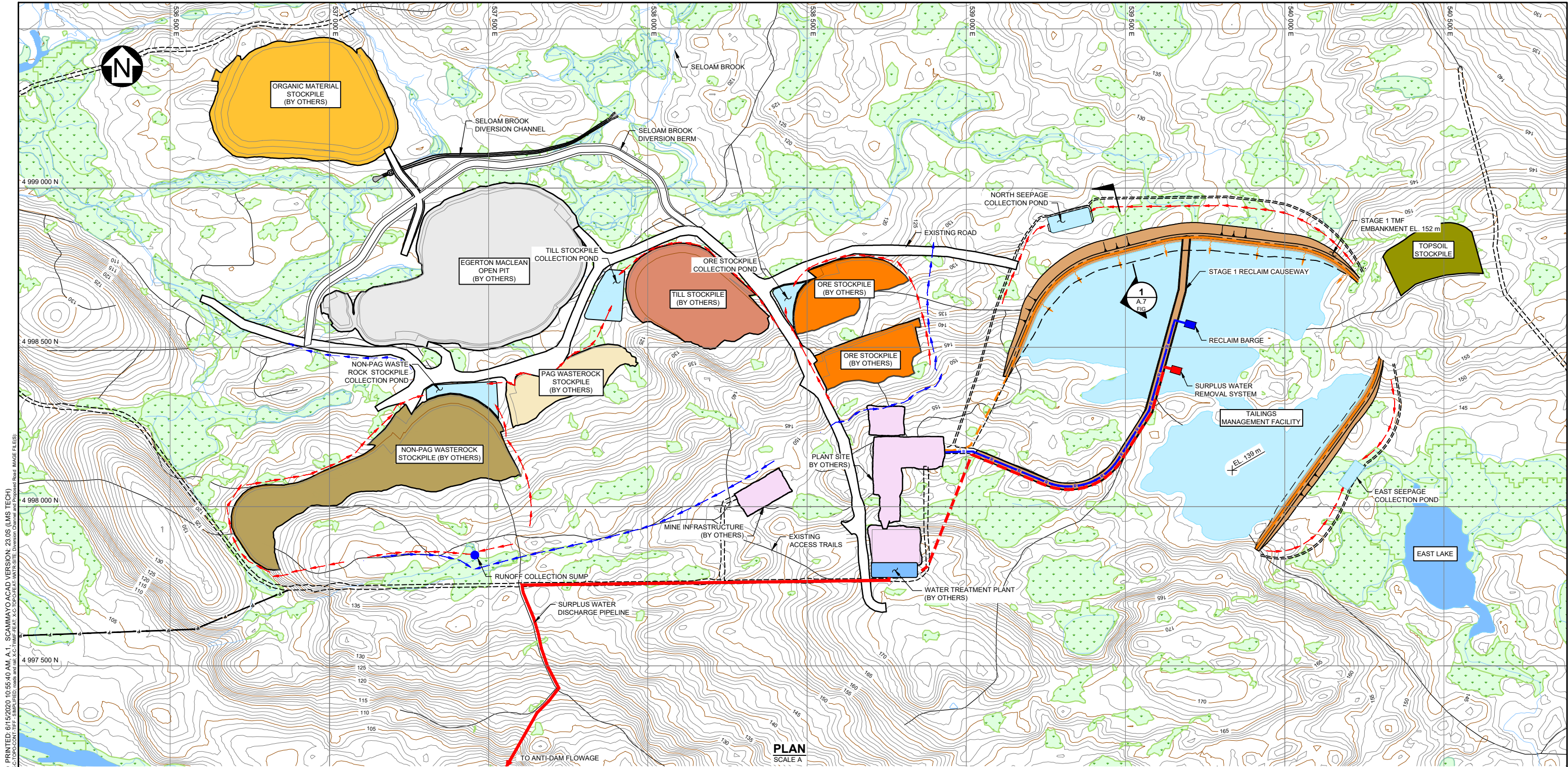

LEGEND:

MINE WATER	PLANT SITE (BY OTHERS)
FRESH WATER	TOPSOIL PILE (BY OTHERS)
EMBANKMENT FILL	RECLAIM PUMPS
WETLAND	SURPLUS WATER REMOVAL SYSTEM
OPEN PIT (BY OTHERS)	WATER MANAGEMENT POND
ORE STOCKPILE (BY OTHERS)	STREAM
PAG STOCKPILE (BY OTHERS)	EXISTING ROAD
NON-PAG STOCKPILE (BY OTHERS)	PROPOSED ROAD
TILL STOCKPILE (BY OTHERS)	SEEPAGE COLLECTION DITCH
ORGANIC MATERIAL STOCKPILE (BY OTHERS)	NON-CONTACT WATER DITCH
	POWERLINE
	RECLAIM WATER PIPE
	SURPLUS WATER PIPELINE
	SURPLUS WATER DISCHARGE PIPELINE
	TAILINGS DISCHARGE PIPE
	TAILINGS DEPOSIT

- NOTES:**
- COORDINATE GRID IS NAD83, ZONE 20 T.
 - CONTOURS BASED ON 2014 LIDAR OBTAINED FROM GEONOVA, REPRODUCED AND DISTRIBUTED WITH THE PERMISSION OF INTERNAL SERVICES. CONTOURS HAVE BEEN PRODUCED BY KNIGHT PIESOLD LTD. AND INCLUDES DATA PROVIDED BY INTERNAL SERVICES. THE INCORPORATION OF DATA SOURCED FROM INTERNAL SERVICES WITHIN THIS PRODUCT SHALL NOT BE CONSTRUED AS CONSTITUTING AN ENDORSEMENT BY INTERNAL SERVICES OF OUR PRODUCT.
 - WETLAND AND WATER COURSE MAPPING PROVIDED BY McCALLUM ENVIRONMENTAL LTD. SEPTEMBER 06, 2018. DATA PROVIDED IN DRAFT WITH NO IMPLIED WARRANTIES AND SHALL BE CONSIDERED PRELIMINARY.
 - DIMENSIONS AND ELEVATIONS ARE IN METRES, UNLESS NOTED OTHERWISE.

FOR INFORMATION ONLY

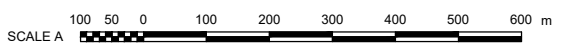

ATLANTIC MINING NS CORP.	
FIFTEEN MILE STREAM PROJECT	
GENERAL ARRANGEMENT STAGE 1 (YEAR -1)	
P/A NO. VA101-708/4	REF NO. 2
FIGURE A.1	

SAVED: M:\110100708\04\A\Acad\FIGS\B12_6\122020_2_58-38 PM - SCAMMAYO ACAD VERSION: 23.05 (LMS TECH)
 REV: 1 12JUN'20 ISSUED WITH REPORT JEF SC DDF
 REV DATE DESCRIPTION DESIGNED DRAWN REVIEWED

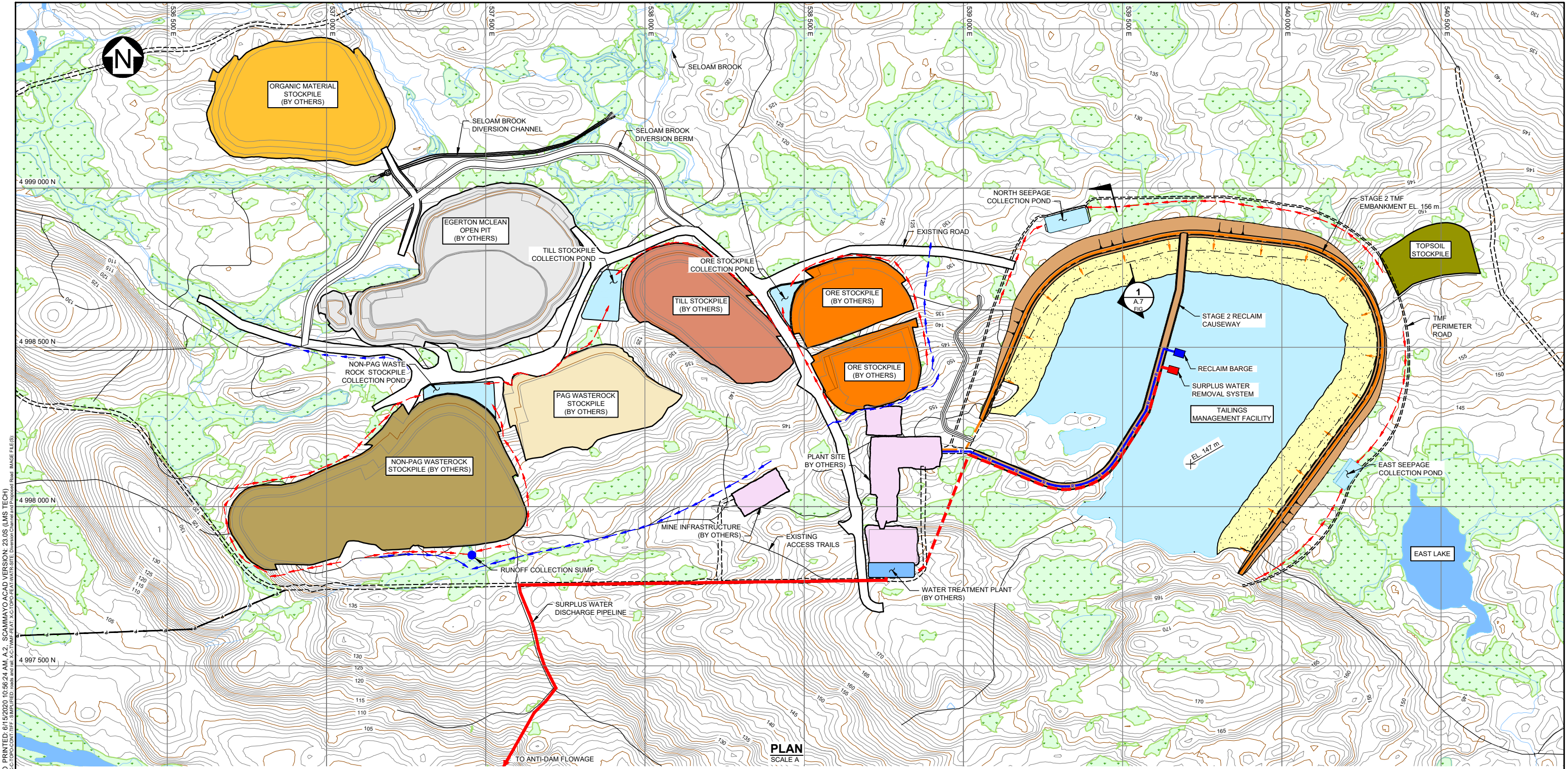

SAVED: M:\10100708\04\A\Acad\FIGS\B13_6\122020_10:56:24 AM_A2_SCAMMAYO.ACAD VERSION: 23.05 (LMS TECH)
 REVISIONS: 12/20/2010 10:56:24 AM A2 SCAMMAYO, PRINTED: 6/15/2020 10:56:24 AM A2, SCAMMAYO ACAD VERSION: 23.05 (LMS TECH)
 FILE(S) BND-CAD: BND-PPT-DRAWING: UPDATE ACCESS ISSUE: THE USER DOES NOT HAVE ACCESS TO THE FILE(S)

PLAN
SCALE A

LEGEND:

- | | |
|--|----------------------------------|
| MINE WATER | PLANT SITE (BY OTHERS) |
| FRESH WATER | TOPSOIL PILE (BY OTHERS) |
| TAILINGS | RECLAIM PUMPS |
| EMBANKMENT FILL | SURPLUS WATER REMOVAL SYSTEM |
| WETLAND | WATER MANAGEMENT POND |
| OPEN PIT (BY OTHERS) | STREAM |
| ORE STOCKPILE (BY OTHERS) | EXISTING ROAD |
| PAG STOCKPILE (BY OTHERS) | PROPOSED ROAD |
| NON-PAG STOCKPILE (BY OTHERS) | SEEPAGE COLLECTION DITCH |
| TILL STOCKPILE (BY OTHERS) | NON-CONTACT WATER DITCH |
| ORGANIC MATERIAL STOCKPILE (BY OTHERS) | POWERLINE |
| | RECLAIM WATER PIPE |
| | SURPLUS WATER PIPELINE |
| | SURPLUS WATER DISCHARGE PIPELINE |
| | TAILINGS DISCHARGE PIPE |
| | TAILINGS DEPOSIT |

NOTES:

- COORDINATE GRID IS NAD83, ZONE 20 T.
- CONTOURS BASED ON 2014 LIDAR OBTAINED FROM GEONOVA, REPRODUCED AND DISTRIBUTED WITH THE PERMISSION OF INTERNAL SERVICES. CONTOURS HAVE BEEN PRODUCED BY KNIGHT PIESOLD LTD. AND INCLUDES DATA PROVIDED BY INTERNAL SERVICES. THE INCORPORATION OF DATA SOURCED FROM INTERNAL SERVICES WITHIN THIS PRODUCT SHALL NOT BE CONSTRUED AS CONSTITUTING AN ENDORSEMENT BY INTERNAL SERVICES OF OUR PRODUCT.
- WETLAND AND WATER COURSE MAPPING PROVIDED BY McCALLUM ENVIRONMENTAL LTD. SEPTEMBER 06, 2018. DATA PROVIDED IN DRAFT WITH NO IMPLIED WARRANTIES AND SHALL BE CONSIDERED PRELIMINARY.
- DIMENSIONS AND ELEVATIONS ARE IN METRES, UNLESS NOTED OTHERWISE.

FOR INFORMATION ONLY

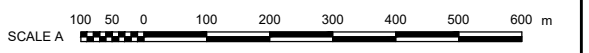

ATLANTIC MINING NS CORP.	
FIFTEEN MILE STREAM PROJECT	
GENERAL ARRANGEMENT STAGE 2 (YEAR 1)	
P/A NO. VA101-708/4	REF NO. 2
FIGURE A.2	
	REV 1

REV	DATE	DESCRIPTION	DESIGNED	DRAWN	REVIEWED
1	12JUN20	ISSUED WITH REPORT	JEF	SC	DDF

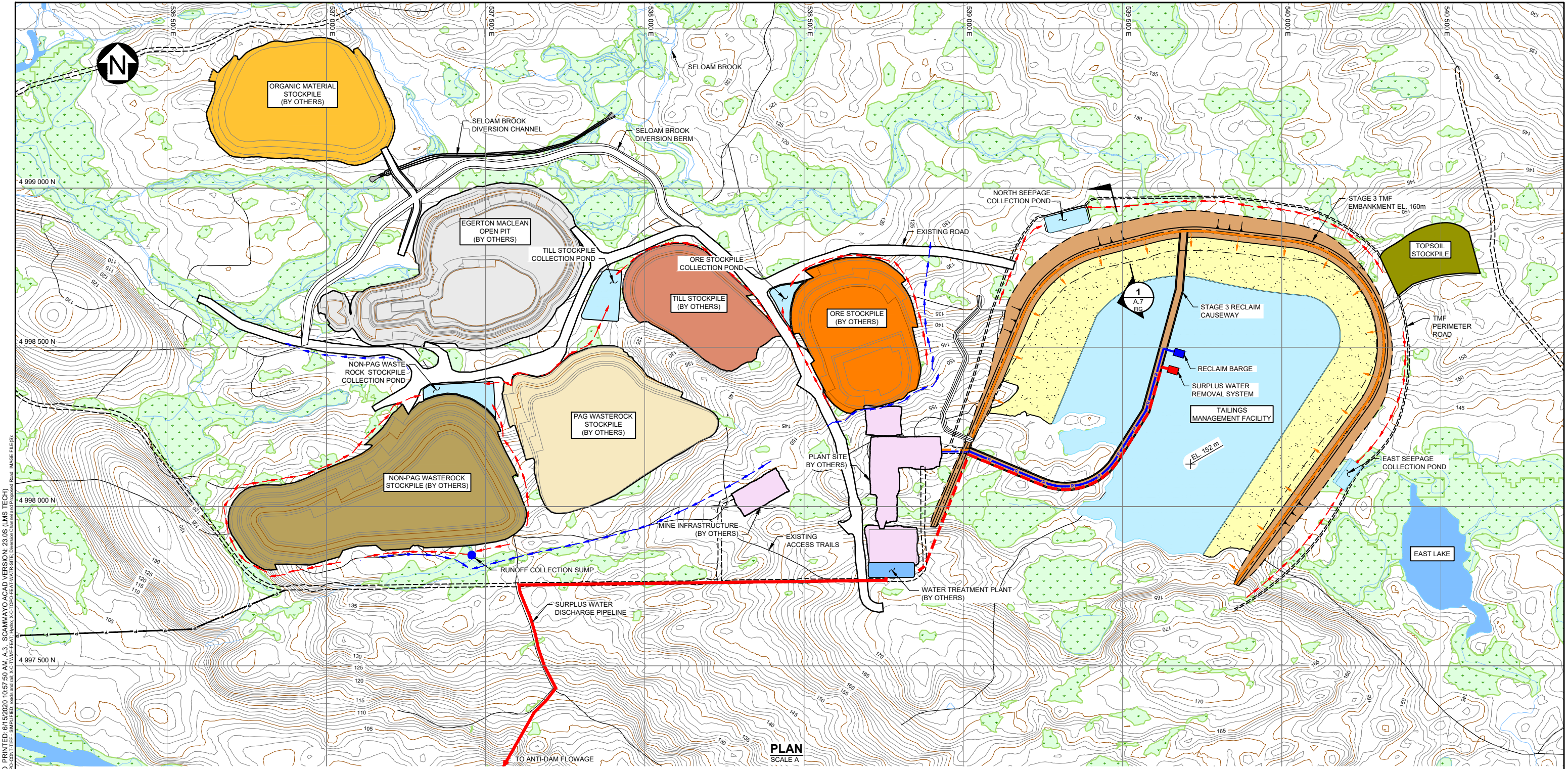

SAVED: M:\110100708\04\A\Acad\FIGS\B14_6\122020_3.02.04 PM - SCAMMAYO ACAD VERSION: 23.05 (LMS TECH)
 REVISIONS: 12/20/2010 10:57:50 AM A.3 SCAMMAYO ACAD VERSION: 23.05 (LMS TECH)
 REVISIONS: 12/20/2010 10:57:50 AM A.3 SCAMMAYO ACAD VERSION: 23.05 (LMS TECH)
 REVISIONS: 12/20/2010 10:57:50 AM A.3 SCAMMAYO ACAD VERSION: 23.05 (LMS TECH)
 REVISIONS: 12/20/2010 10:57:50 AM A.3 SCAMMAYO ACAD VERSION: 23.05 (LMS TECH)

PLAN
SCALE A

LEGEND:

- | | |
|--|----------------------------------|
| MINE WATER | PLANT SITE (BY OTHERS) |
| FRESH WATER | TOPSOIL PILE (BY OTHERS) |
| TAILINGS | RECLAIM PUMPS |
| EMBANKMENT FILL | SURPLUS WATER REMOVAL SYSTEM |
| WETLAND | WATER MANAGEMENT POND |
| OPEN PIT (BY OTHERS) | STREAM |
| ORE STOCKPILE (BY OTHERS) | EXISTING ROAD |
| PAG STOCKPILE (BY OTHERS) | PROPOSED ROAD |
| NON-PAG STOCKPILE (BY OTHERS) | SEEPAGE COLLECTION DITCH |
| TILL STOCKPILE (BY OTHERS) | NON-CONTACT WATER DITCH |
| ORGANIC MATERIAL STOCKPILE (BY OTHERS) | POWERLINE |
| | RECLAIM WATER PIPE |
| | SURPLUS WATER PIPELINE |
| | SURPLUS WATER DISCHARGE PIPELINE |
| | TAILINGS DISCHARGE PIPE |
| | TAILINGS DEPOSIT |

NOTES:

- COORDINATE GRID IS NAD83, ZONE 20 T.
- CONTOURS BASED ON 2014 LIDAR OBTAINED FROM GEONOVA, REPRODUCED AND DISTRIBUTED WITH THE PERMISSION OF INTERNAL SERVICES. CONTOURS HAVE BEEN PRODUCED BY KNIGHT PIESOLD LTD. AND INCLUDES DATA PROVIDED BY INTERNAL SERVICES. THE INCORPORATION OF DATA SOURCED FROM INTERNAL SERVICES WITHIN THIS PRODUCT SHALL NOT BE CONSTRUED AS CONSTITUTING AN ENDORSEMENT BY INTERNAL SERVICES OF OUR PRODUCT.
- WETLAND AND WATER COURSE MAPPING PROVIDED BY McCALLUM ENVIRONMENTAL LTD. SEPTEMBER 06, 2018. DATA PROVIDED IN DRAFT WITH NO IMPLIED WARRANTIES AND SHALL BE CONSIDERED PRELIMINARY.
- DIMENSIONS AND ELEVATIONS ARE IN METRES, UNLESS NOTED OTHERWISE.

FOR INFORMATION ONLY

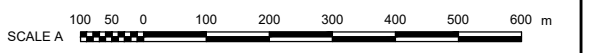

ATLANTIC MINING NS CORP.	
FIFTEEN MILE STREAM PROJECT	
GENERAL ARRANGEMENT STAGE 3 (YEAR 3)	
P/A NO. VA101-708/4	REF NO. 2
FIGURE A.3	
Knight Piesold CONSULTING	REV 1

REV	DATE	DESCRIPTION	DESIGNED	DRAWN	REVIEWED
1	12JUN'20	ISSUED WITH REPORT	JEF	SC	DDF

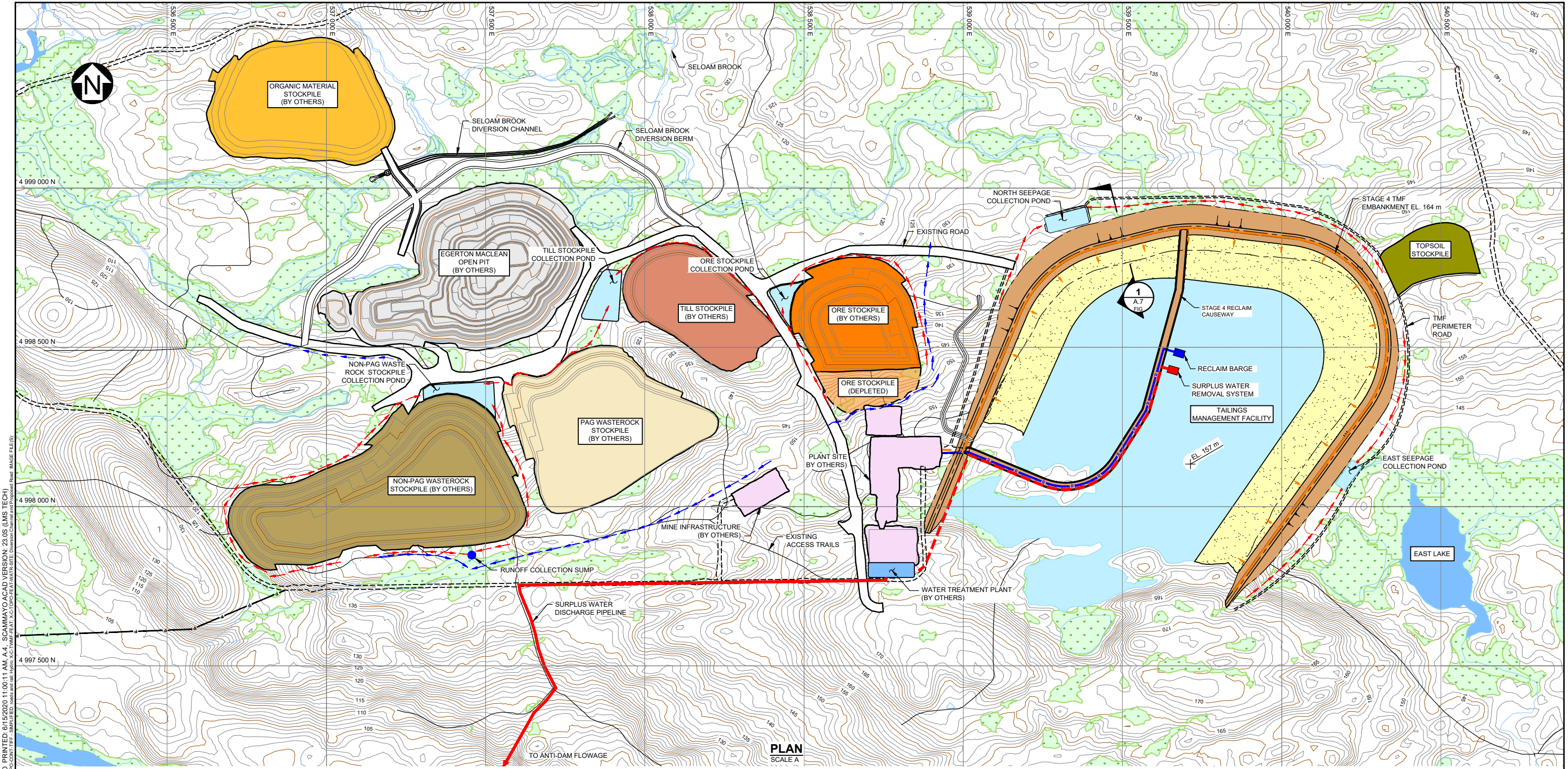

SAVED: M:\10100708\04\A\Acad\FIGS\B15_6/12/2020 3:02:50 PM - SCAMMAYO ACAD VERSION: 23.05 (LMS TECH)
 FILE(S) BND\CADD\BND\PTT\DATA\IE_UPDATE\FACILITY_ACCESS_DRAWING_6_X32.DWG (DATE: 6/12/2020 3:02:50 PM)

PLAN
SCALE A

LEGEND:

- | | |
|--|----------------------------------|
| MINE WATER | PLANT SITE (BY OTHERS) |
| FRESH WATER | TOPSOIL PILE (BY OTHERS) |
| TAILINGS | RECLAIM PUMPS |
| EMBANKMENT FILL | SURPLUS WATER REMOVAL SYSTEM |
| WETLAND | WATER MANAGEMENT POND |
| OPEN PIT (BY OTHERS) | STREAM |
| ORE STOCKPILE (BY OTHERS) | EXISTING ROAD |
| PAG STOCKPILE (BY OTHERS) | PROPOSED ROAD |
| NON-PAG STOCKPILE (BY OTHERS) | SEEPAGE COLLECTION DITCH |
| TILL STOCKPILE (BY OTHERS) | NON-CONTACT WATER DITCH |
| ORGANIC MATERIAL STOCKPILE (BY OTHERS) | POWERLINE |
| | RECLAIM WATER PIPE |
| | SURPLUS WATER PIPELINE |
| | SURPLUS WATER DISCHARGE PIPELINE |
| | TAILINGS DISCHARGE PIPE |
| | TAILINGS DEPOSIT |

NOTES:

- COORDINATE GRID IS NAD83, ZONE 20 T.
- CONTOURS BASED ON 2014 LIDAR OBTAINED FROM GEONOVA, REPRODUCED AND DISTRIBUTED WITH THE PERMISSION OF INTERNAL SERVICES. CONTOURS HAVE BEEN PRODUCED BY KNIGHT PIESOLD LTD. AND INCLUDES DATA PROVIDED BY INTERNAL SERVICES. THE INCORPORATION OF DATA SOURCED FROM INTERNAL SERVICES WITHIN THIS PRODUCT SHALL NOT BE CONSTRUED AS CONSTITUTING AN ENDORSEMENT BY INTERNAL SERVICES OF OUR PRODUCT.
- WETLAND AND WATER COURSE MAPPING PROVIDED BY McCALLUM ENVIRONMENTAL LTD. SEPTEMBER 06, 2018. DATA PROVIDED IN DRAFT WITH NO IMPLIED WARRANTIES AND SHALL BE CONSIDERED PRELIMINARY.
- DIMENSIONS AND ELEVATIONS ARE IN METRES, UNLESS NOTED OTHERWISE.

FOR INFORMATION ONLY

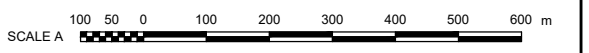

ATLANTIC MINING NS CORP.	
FIFTEEN MILE STREAM PROJECT	
GENERAL ARRANGEMENT STAGE 4 (YEAR 6)	
P/A NO. VA101-708/4	REF NO. 2
FIGURE A.4	
REV 1	1



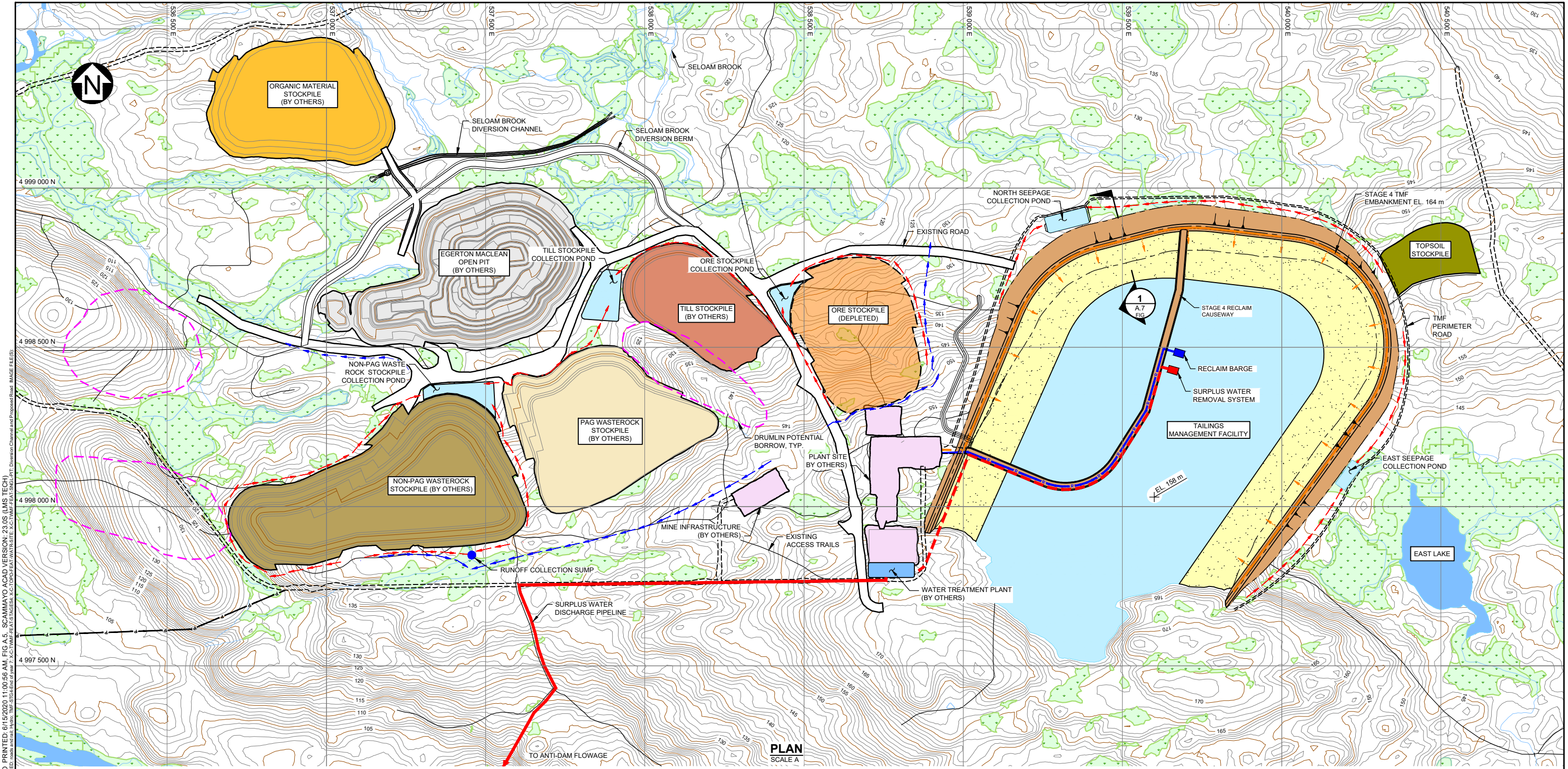







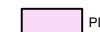





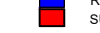



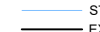
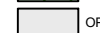
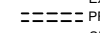

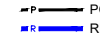

REV	DATE	DESCRIPTION	DESIGNED	DRAWN	REVIEWED
1	12JUN'20	ISSUED WITH REPORT	JEF	SC	DDF



SAVED: M:\10100708\04\A\Acad\FIGS\B16_6\122020_11:00:56 AM FIG A.5 - SCAMMAYO ACAD VERSION: 23.05 (LMS TECH)
 FILE(S) AND C:\Users\pjt\Documents\Projects\FIFTEEN MILE STREAM\PROJECT\DWG\FIFTEEN MILE STREAM\GENERAL ARRANGEMENT\GENERAL ARRANGEMENT_STAGE 4_YEAR 7.dwg
 PLOTTED: 2020 JUN 12 11:00:56 AM
 PLOTTER: HP DesignJet T1200

PLAN
SCALE A

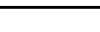
LEGEND:

- | | | | |
|--|--|---|----------------------------------|
|  | MINE WATER |  | PLANT SITE (BY OTHERS) |
|  | FRESH WATER |  | TOPSOIL PILE (BY OTHERS) |
|  | TAILINGS |  | RECLAIM PUMPS |
|  | EMBANKMENT FILL |  | SURPLUS WATER REMOVAL SYSTEM |
|  | WETLAND |  | WATER MANAGEMENT POND |
|  | OPEN PIT (BY OTHERS) |  | STREAM |
|  | ORE STOCKPILE (DEPLETED) |  | EXISTING ROAD |
|  | PAG STOCKPILE (BY OTHERS) |  | PROPOSED ROAD |
|  | NON-PAG STOCKPILE (BY OTHERS) |  | SEEPAGE COLLECTION DITCH |
|  | TILL STOCKPILE (BY OTHERS) |  | NON-CONTACT WATER DITCH |
|  | ORGANIC MATERIAL STOCKPILE (BY OTHERS) |  | POWERLINE |
| | |  | RECLAIM WATER PIPE |
| | |  | SURPLUS WATER PIPELINE |
| | |  | SURPLUS WATER DISCHARGE PIPELINE |
| | |  | TAILINGS DISCHARGE PIPE |
| | |  | TAILINGS DEPOSIT |

NOTES:

- COORDINATE GRID IS NAD83, ZONE 20 T.
- CONTOURS BASED ON 2014 LIDAR OBTAINED FROM GEONOVA, REPRODUCED AND DISTRIBUTED WITH THE PERMISSION OF INTERNAL SERVICES. CONTOURS HAVE BEEN PRODUCED BY KNIGHT PIESOLD LTD. AND INCLUDES DATA PROVIDED BY INTERNAL SERVICES. THE INCORPORATION OF DATA SOURCED FROM INTERNAL SERVICES WITHIN THIS PRODUCT SHALL NOT BE CONSTRUED AS CONSTITUTING AN ENDORSEMENT BY INTERNAL SERVICES OF OUR PRODUCT.
- WETLAND AND WATER COURSE MAPPING PROVIDED BY McCALLUM ENVIRONMENTAL LTD. SEPTEMBER 06, 2018. DATA PROVIDED IN DRAFT WITH NO IMPLIED WARRANTIES AND SHALL BE CONSIDERED PRELIMINARY.
- DIMENSIONS AND ELEVATIONS ARE IN METRES, UNLESS NOTED OTHERWISE.

FOR INFORMATION ONLY

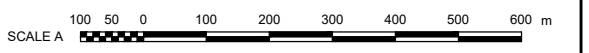

ATLANTIC MINING NS CORP.			
FIFTEEN MILE STREAM PROJECT			
GENERAL ARRANGEMENT STAGE 4 (YEAR 7)			
	P/A NO. VA101-708/4	REF NO. 2	FIGURE A.5

REV	DATE	DESCRIPTION	DESIGNED	DRAWN	REVIEWED
1	12JUN'20	ISSUED WITH REPORT	JEF	RMM/SC	DDF

SAVED: M:\10100708\04\A\Acad\FIGS\B20_6122020_9:24:58 AM - SCAMMAYO PRINTED: 6/12/2020 10:46:54 AM A.6. SCAMMAYO ACAD VERSION: 23.05 (LMS TECH)
 REVISIONS: 1.00 (M:\10100708\04\A\Acad\FIGS\B20_6122020_9:24:58 AM - SCAMMAYO PRINTED: 6/12/2020 10:46:54 AM A.6. SCAMMAYO ACAD VERSION: 23.05 (LMS TECH))
 REVISIONS: 1.00 (M:\10100708\04\A\Acad\FIGS\B20_6122020_9:24:58 AM - SCAMMAYO PRINTED: 6/12/2020 10:46:54 AM A.6. SCAMMAYO ACAD VERSION: 23.05 (LMS TECH))

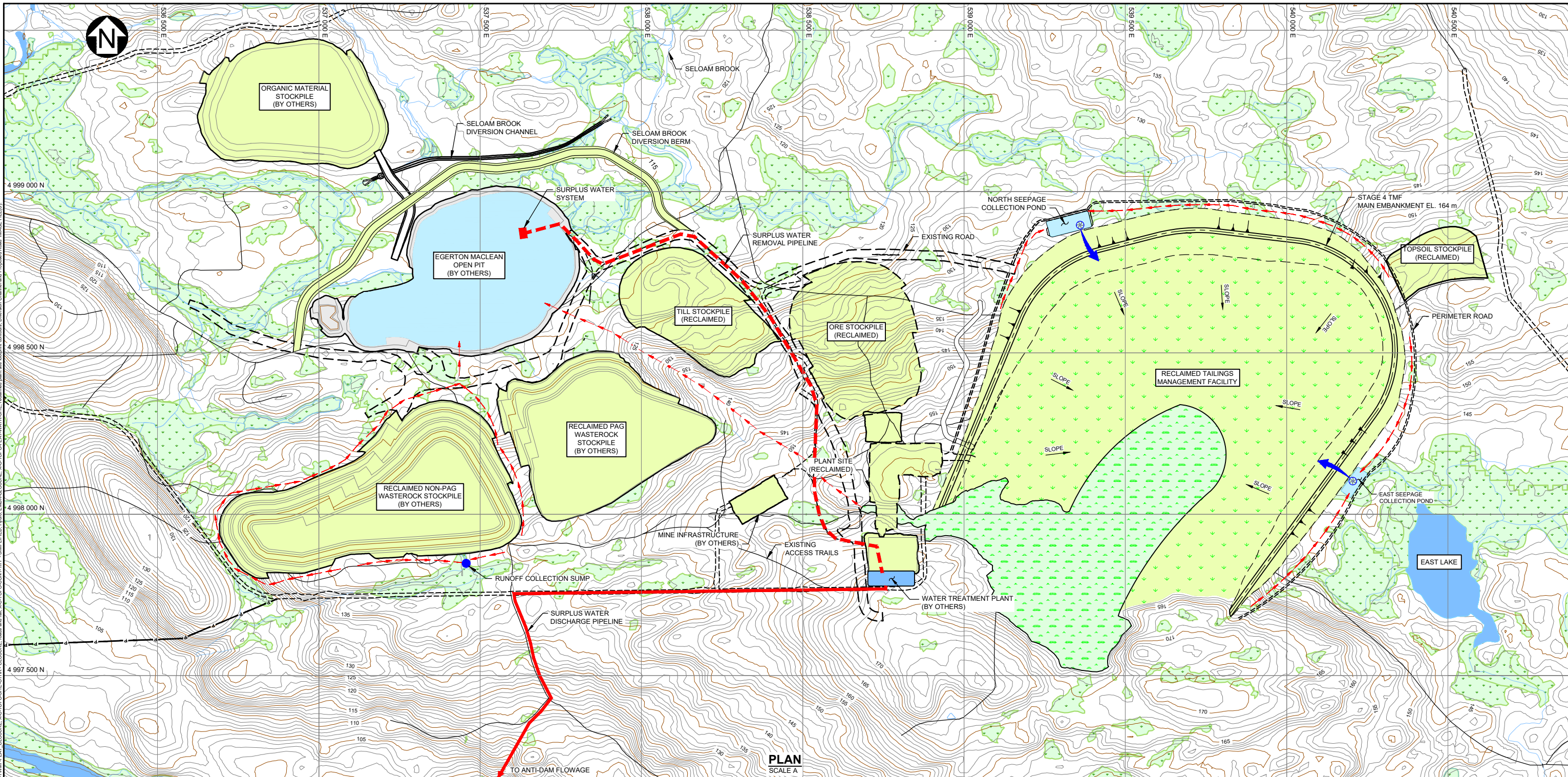

LEGEND:

- UPLAND SLOPE
- UPLAND BEACH
- BOG / WETLAND AREA
- MINE WATER
- FRESH WATER
- SURPLUS WATER PIPELINE
- STREAM
- EXISTING ROAD
- PROPOSED ACCESS ROAD
- POWERLINE
- COLLECTION DITCH
- NON-CONTACT WATER DITCH
- PUMPBACK SYSTEM

NOTES:

1. COORDINATE GRID IS NAD83, ZONE 20 T.
2. CONTOURS BASED ON 2014 LIDAR OBTAINED FROM GEONOVA, REPRODUCED AND DISTRIBUTED WITH THE PERMISSION OF INTERNAL SERVICES. CONTOURS HAVE BEEN PRODUCED BY KNIGHT PIESOLD LTD. AND INCLUDES DATA PROVIDED BY INTERNAL SERVICES. THE INCORPORATION OF DATA SOURCED FROM INTERNAL SERVICES WITHIN THIS PRODUCT SHALL NOT BE CONSTRUED AS CONSTITUTING AN ENDORSEMENT BY INTERNAL SERVICES OF OUR PRODUCT.
3. WETLAND AND WATER COURSE MAPPING PROVIDED BY McCALLUM ENVIRONMENTAL LTD. SEPTEMBER 06, 2018. DATA PROVIDED IN DRAFT WITH NO IMPLIED WARRANTIES AND SHALL BE CONSIDERED PRELIMINARY.
4. DIMENSIONS AND ELEVATIONS ARE IN METRES, UNLESS NOTED OTHERWISE.

FOR INFORMATION ONLY

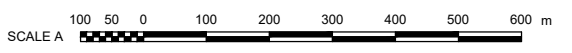

ATLANTIC MINING NS CORP.	
FIFTEEN MILE STREAM PROJECT	
GENERAL ARRANGEMENT CLOSURE	
P/A NO. VA101-708/4	REF NO. 2
FIGURE A.6	

REV	DATE	DESCRIPTION	DESIGNED	DRAWN	REVIEWED
1	12JUN20	ISSUED WITH REPORT	JEF	SC	DDF

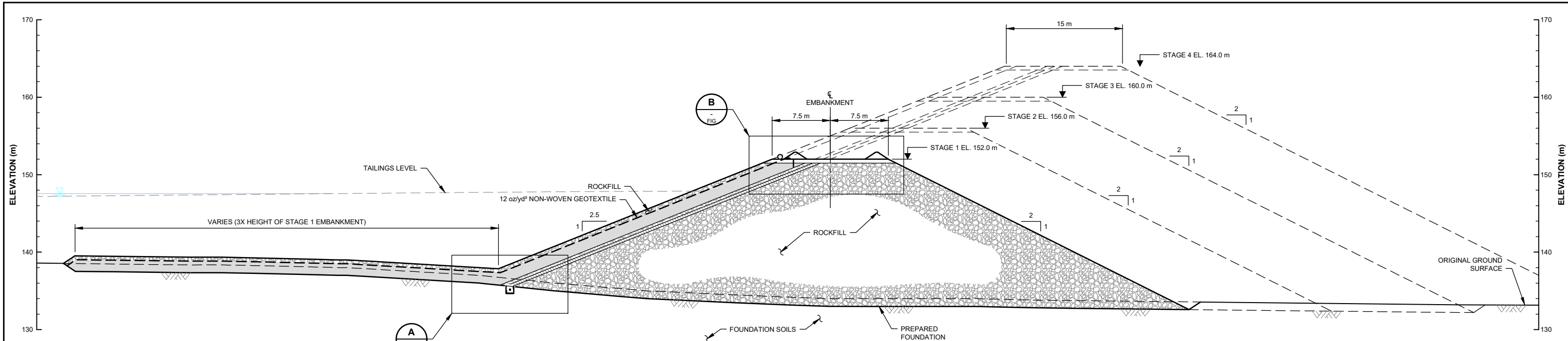

SECTION
TYPICAL EMBANKMENT DESIGN SECTION
 SCALE A

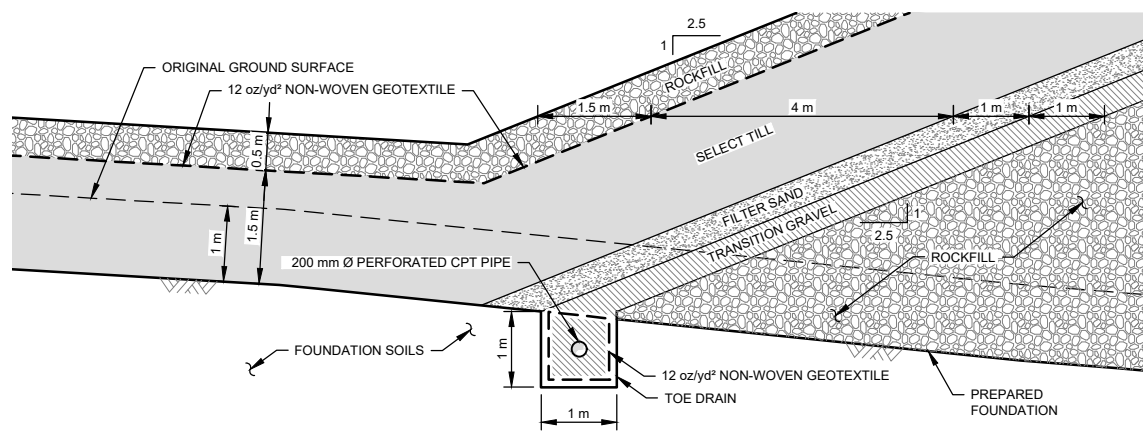

A
DETAIL
TOE DRAIN
 SCALE B

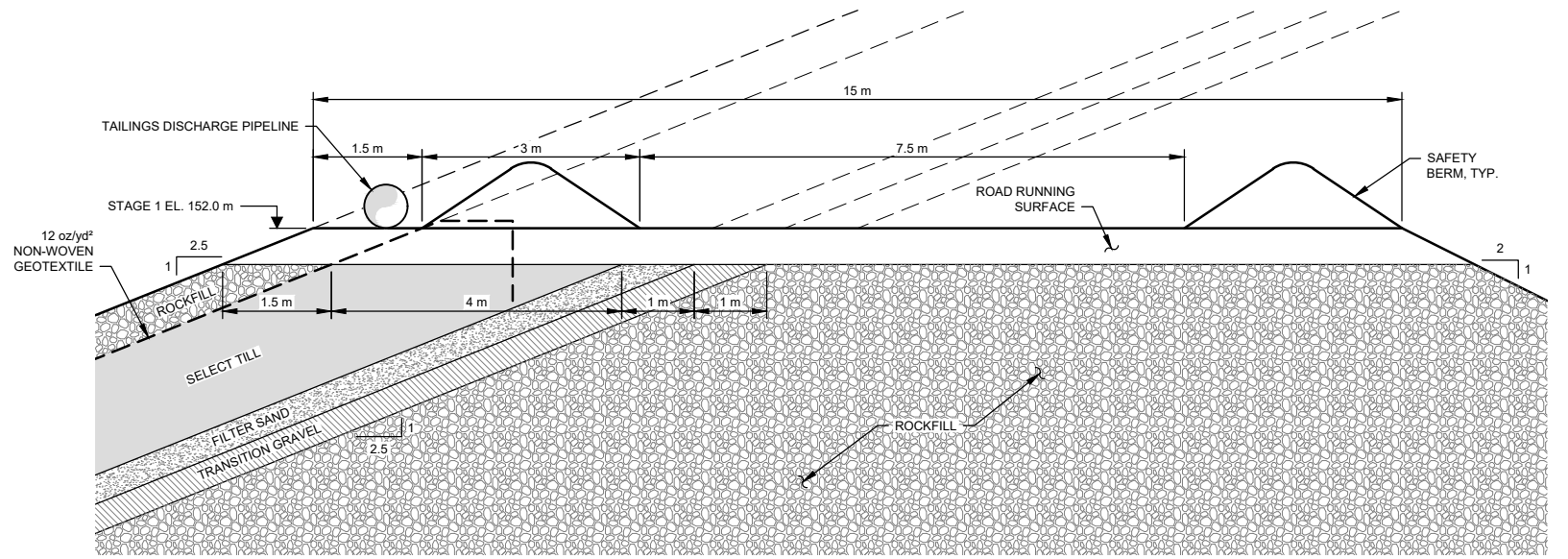

B
DETAIL
STAGE 1 CREST
 SCALE B

- LEGEND:**
- ROCKFILL
 - SELECT TILL
 - FILTER SAND
 - TRANSITION GRAVEL

NOTES:
 1. DIMENSIONS AND ELEVATIONS ARE IN METRES, UNLESS NOTED OTHERWISE.

FOR INFORMATION ONLY



ATLANTIC MINING NS CORP.	
FIFTEEN MILE STREAM PROJECT	
TMF EMBANKMENT CROSS-SECTION	
P/A NO. VA101-708/4	REF NO. 2
FIGURE A.7	
	REV 1

SAVED: M:\110100708\04\AA\Acad\FIGS\B35_6\11\2020 3:49:51 PM - SCAMMAYO PRINTED: 6/12/2020 10:47:50 AM FIG A.7 - SCAMMAYO ACAD VERSION: 23.05 (LMS TECH)

REV	DATE	DESCRIPTION	DESIGNED	DRAWN	REVIEWED
1	12JUN'20	ISSUED WITH REPORT	JEF	SC	DDF

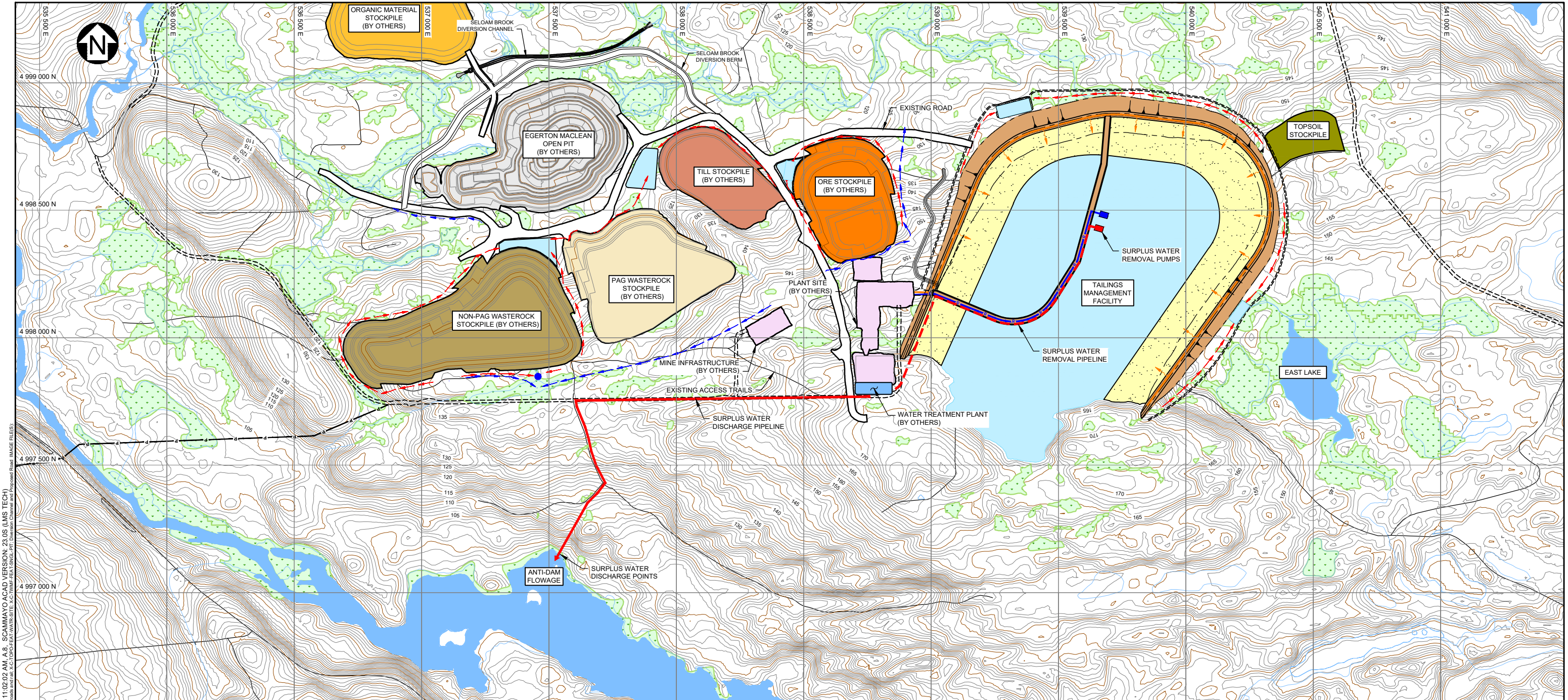

PLAN
SCALE A

LEGEND:

- | | |
|--|----------------------------------|
| MINE WATER | PLANT SITE (BY OTHERS) |
| FRESH WATER | TOPSOIL PILE (BY OTHERS) |
| TAILINGS | RECLAIM PUMPS |
| EMBANKMENT FILL | SURPLUS WATER REMOVAL SYSTEM |
| WETLAND | WATER MANAGEMENT POND |
| OPEN PIT (BY OTHERS) | STREAM |
| ORE STOCKPILE (BY OTHERS) | EXISTING ROAD |
| PAG STOCKPILE (BY OTHERS) | PROPOSED ROAD |
| NON-PAG STOCKPILE (BY OTHERS) | SEEPAGE COLLECTION DITCH |
| TILL STOCKPILE (BY OTHERS) | NON-CONTACT WATER DITCH |
| ORGANIC MATERIAL STOCKPILE (BY OTHERS) | POWERLINE |
| | RECLAIM WATER PIPE |
| | SURPLUS WATER PIPELINE |
| | SURPLUS WATER DISCHARGE PIPELINE |
| | TAILINGS DISCHARGE PIPE |
| | TAILINGS DEPOSIT |

NOTES:

- COORDINATE GRID IS NAD83, ZONE 20 T.
- CONTOURS BASED ON 2014 LIDAR OBTAINED FROM GEONOVA, REPRODUCED AND DISTRIBUTED WITH THE PERMISSION OF INTERNAL SERVICES. CONTOURS HAVE BEEN PRODUCED BY KNIGHT PIESOLD LTD. AND INCLUDES DATA PROVIDED BY INTERNAL SERVICES. THE INCORPORATION OF DATA SOURCED FROM INTERNAL SERVICES WITHIN THIS PRODUCT SHALL NOT BE CONSTRUED AS CONSTITUTING AN ENDORSEMENT BY INTERNAL SERVICES OF OUR PRODUCT.
- WETLAND AND WATER COURSE MAPPING PROVIDED BY McCALLUM ENVIRONMENTAL LTD. SEPTEMBER 06, 2018. DATA PROVIDED IN DRAFT WITH NO IMPLIED WARRANTIES AND SHALL BE CONSIDERED PRELIMINARY.
- DIMENSIONS AND ELEVATIONS ARE IN METRES, UNLESS NOTED OTHERWISE.

FOR INFORMATION ONLY

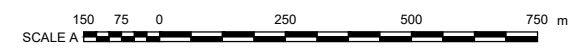

ATLANTIC MINING NS CORP.	
FIFTEEN MILE STREAM PROJECT	
SURPLUS WATER MANAGEMENT SYSTEM PLAN	
P/I NO. VA101-708/4	REF NO. 2
Knight Piesold CONSULTING	FIGURE A.8
REV 1	REV 1

SAVED: M:\10100708\04\Acad\FIGS\B21_6\15/2020 3:06:33 PM - SCAMMAYO PRINTED: 6/15/2020 11:02:02 AM A.B. SCAMMAYO ACAD VERSION: 23.05 (LMS TECH)
 FILE(S) AND C:\Users\p111\OneDrive - Knight Piesold\Documents\10100708\04\Acad\FIGS\B21_6\15/2020 3:06:33 PM - SCAMMAYO PRINTED: 6/15/2020 11:02:02 AM A.B. SCAMMAYO ACAD VERSION: 23.05 (LMS TECH)

REV	DATE	DESCRIPTION	DESIGNED	DRAWN	REVIEWED
1	12JUN'20	ISSUED WITH REPORT	JEF	SC	DDF

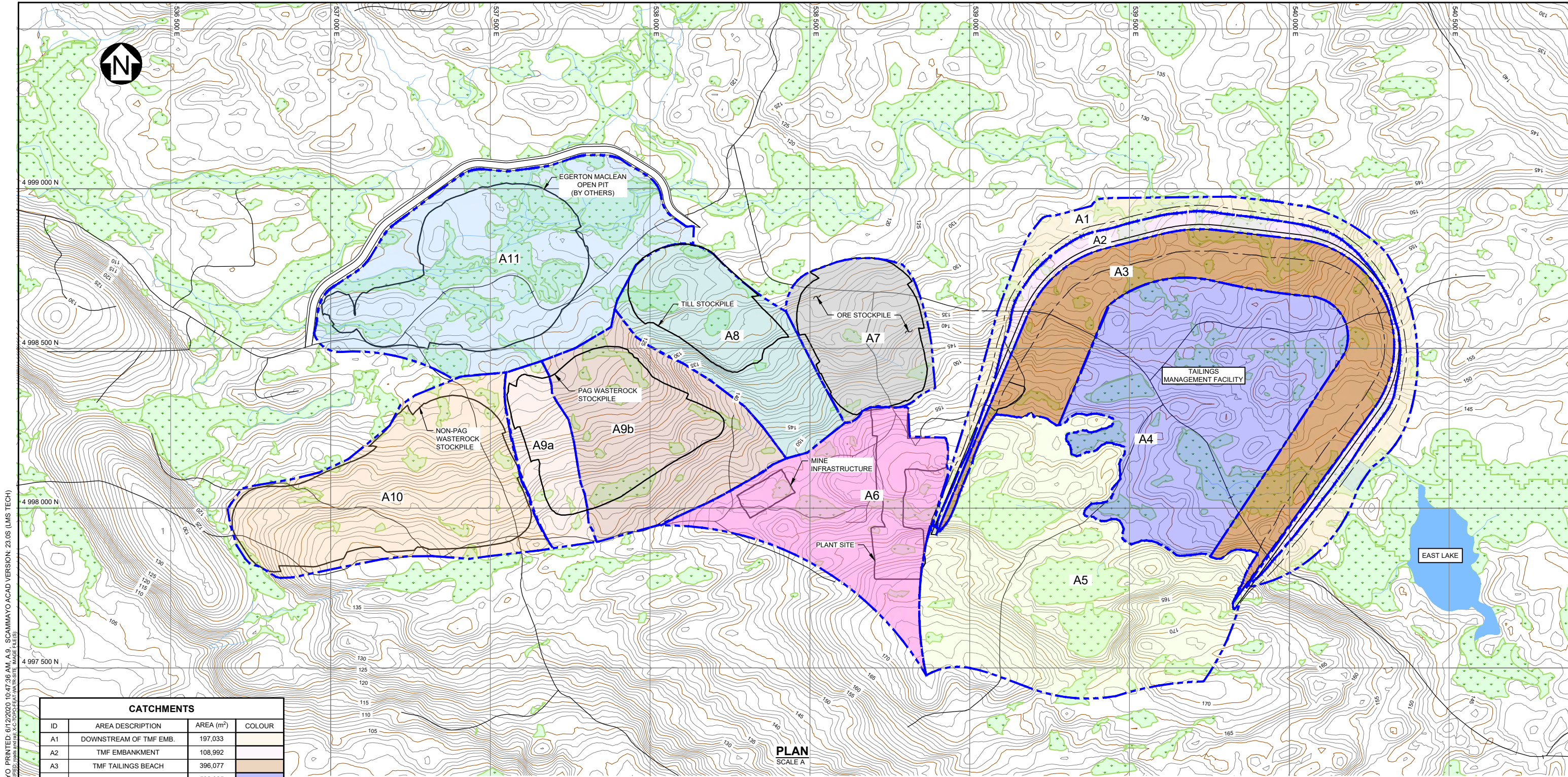

SAVED: M:\110100708\04\A\Acad\FIGS\B32_6/11/2020 3:48:35 PM - SCAMMAYO PRINTED: 6/12/2020 10:47:36 AM A.9 - SCAMMAYO ACAD VERSION: 23.05 (LMS TECH)
 FILE(S) AND C:\AMT\BDD\PTT\PRIVATE\UPDATE ACCESS BASE_A.CAD\CONTR\PTT - 3/20/2020 10:47:36 AM A.9 - SCAMMAYO ACAD VERSION: 23.05 (LMS TECH)

CATCHMENTS			
ID	AREA DESCRIPTION	AREA (m ²)	COLOUR
A1	DOWNSTREAM OF TMF EMB.	197,033	
A2	TMF EMBANKMENT	108,992	
A3	TMF TAILINGS BEACH	396,077	
A4	TMF SUPERNATANT POND	502,325	
A5	TMF UNDISTURBED CATCHMENT	599,361	
A6	PLANT SITE	293,574	
A7	ORE STOCKPILE	171,922	
A8	TILL AND TOPSOIL STOCKPILE	227,160	
A9a	PAG WASTE ROCK STOCKPILE	94,731	
A9b	PAG WASTE ROCK STOCKPILE	294,944	
A10	NON-PAG WASTE ROCK STOCKPILE	377,989	
A11	EGERTON MACLEAN OPEN PIT	495,562	

LEGEND:
 - - - - - CATCHMENT BOUNDARY

- NOTES:**
- COORDINATE GRID IS NAD83, ZONE 20 T.
 - CONTOURS BASED ON 2014 LIDAR OBTAINED FROM GEONOVA. REPRODUCED AND DISTRIBUTED WITH THE PERMISSION OF INTERNAL SERVICES. CONTOURS HAVE BEEN PRODUCED BY KNIGHT PIESOLD LTD. AND INCLUDES DATA PROVIDED BY INTERNAL SERVICES. THE INCORPORATION OF DATA SOURCED FROM INTERNAL SERVICES WITHIN THIS PRODUCT SHALL NOT BE CONSTRUED AS CONSTITUTING AN ENDORSEMENT BY INTERNAL SERVICES OF OUR PRODUCT.
 - WETLAND AND WATER COURSE MAPPING PROVIDED BY McCALLUM ENVIRONMENTAL LTD. SEPTEMBER 06, 2018. DATA PROVIDED IN DRAFT WITH NO IMPLIED WARRANTIES AND SHALL BE CONSIDERED PRELIMINARY.
 - DIMENSIONS AND ELEVATIONS ARE IN METRES, UNLESS NOTED OTHERWISE.
 - LAYOUT IS FROM YEAR 3.

PLAN
SCALE A

FOR INFORMATION ONLY

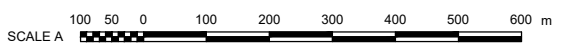

ATLANTIC MINING NS CORP.	
FIFTEEN MILE STREAM PROJECT	
CATCHMENT AREA MAP YEAR -1 TO 3	
	P/A NO. VA101-708/4 REF NO. 2 FIGURE A.9
REV 1	1

REV	DATE	DESCRIPTION	DESIGNED	DRAWN	REVIEWED
1	12JUN'20	ISSUED WITH REPORT	JEF	SC	DDF

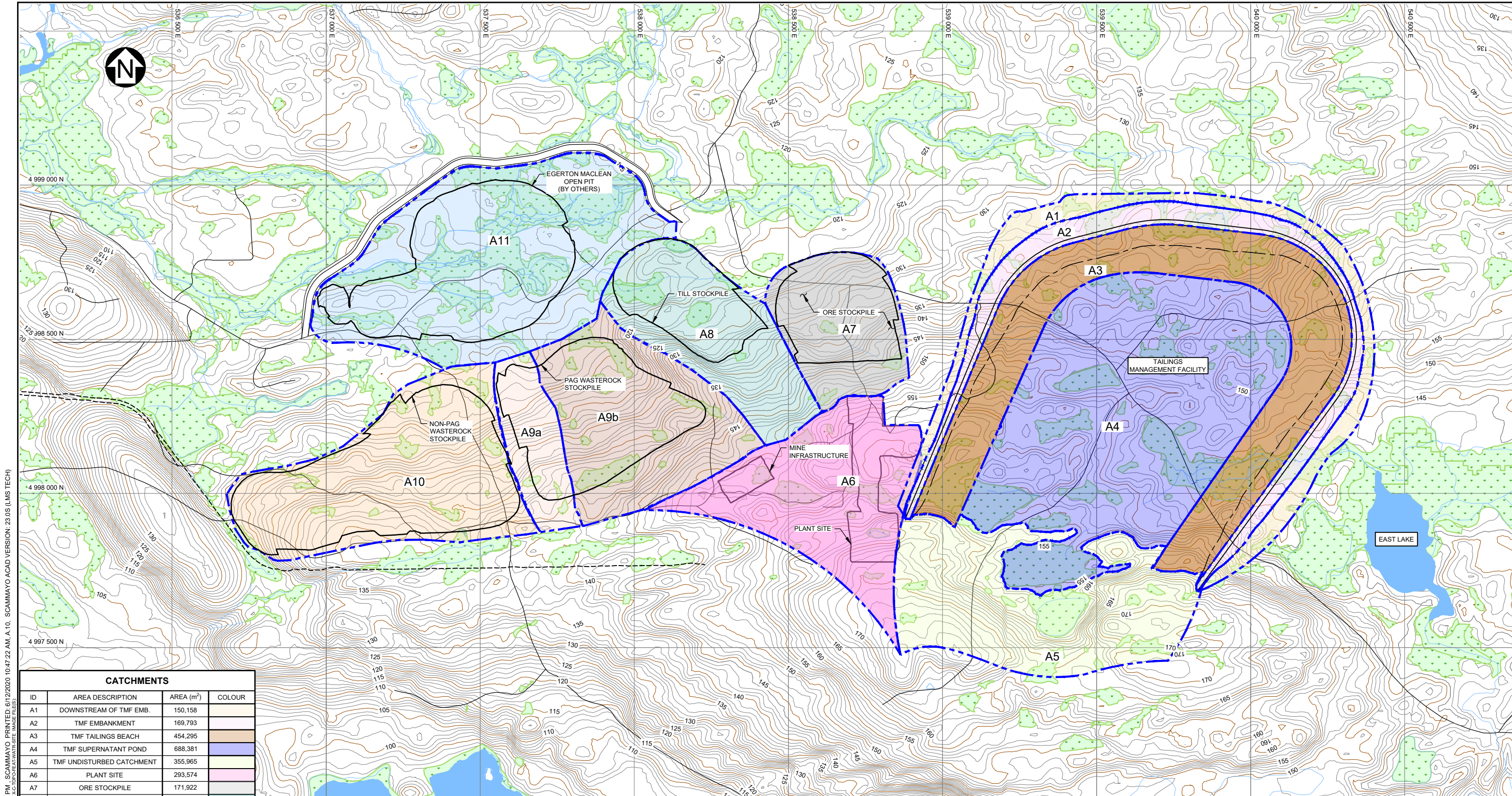

CATCHMENTS			
ID	AREA DESCRIPTION	AREA (m ²)	COLOUR
A1	DOWNSTREAM OF TMF EMB.	150,158	
A2	TMF EMBANKMENT	169,793	
A3	TMF TAILINGS BEACH	454,295	
A4	TMF SUPERNATANT POND	688,381	
A5	TMF UNDISTURBED CATCHMENT	355,965	
A6	PLANT SITE	293,574	
A7	ORE STOCKPILE	171,922	
A8	TILL AND TOPSOIL STOCKPILE	227,160	
A9a	PAG WASTE ROCK STOCKPILE	94,731	
A9b	PAG WASTE ROCK STOCKPILE	294,944	
A10	NON-PAG WASTE ROCK STOCKPILE	377,989	
A11	EGERTON MACLEAN OPEN PIT	495,562	

LEGEND:
 CATCHMENT BOUNDARY

- NOTES:**
- COORDINATE GRID IS NAD83, ZONE 20 T.
 - CONTOURS BASED ON 2014 LIDAR OBTAINED FROM GEONOVA, REPRODUCED AND DISTRIBUTED WITH THE PERMISSION OF INTERNAL SERVICES. CONTOURS HAVE BEEN PRODUCED BY KNIGHT PIESOLD LTD. AND INCLUDES DATA PROVIDED BY INTERNAL SERVICES. THE INCORPORATION OF DATA SOURCED FROM INTERNAL SERVICES WITHIN THIS PRODUCT SHALL NOT BE CONSTRUED AS CONSTITUTING AN ENDORSEMENT BY INTERNAL SERVICES OF OUR PRODUCT.
 - WETLAND AND WATER COURSE MAPPING PROVIDED BY McCALLUM ENVIRONMENTAL LTD. SEPTEMBER 06, 2018. DATA PROVIDED IN DRAFT WITH NO IMPLIED WARRANTIES AND SHALL BE CONSIDERED PRELIMINARY.
 - DIMENSIONS AND ELEVATIONS ARE IN METRES, UNLESS NOTED OTHERWISE.
 - LAYOUT IS FROM YEAR 6.

PLAN
SCALE A

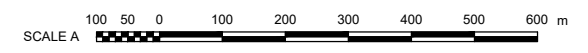

FOR INFORMATION ONLY

SAVED: M:\110100708\04\AAAcad\FIGS\B28_6\112020 4:14:20 PM - SCAMMAYO PRINTED: 6/11/2020 10:47:22 AM A.10. SCAMMAYO ACAD VERSION: 23.05 (LMS TECH)

REV	DATE	DESCRIPTION	DESIGNED	DRAWN	REVIEWED
1	12JUN'20	ISSUED WITH REPORT	JEF	SC	DDF

ATLANTIC MINING NS CORP.							
FIFTEEN MILE STREAM PROJECT							
CATCHMENT AREA MAP YEAR 4 TO 6							
	<table border="1"> <tr> <td>P/A NO. VA101-708/4</td> <td>REF NO. 2</td> </tr> <tr> <td colspan="2" style="text-align: center;">FIGURE A.10</td> </tr> <tr> <td></td> <td style="text-align: right;">REV 1</td> </tr> </table>	P/A NO. VA101-708/4	REF NO. 2	FIGURE A.10			REV 1
P/A NO. VA101-708/4	REF NO. 2						
FIGURE A.10							
	REV 1						

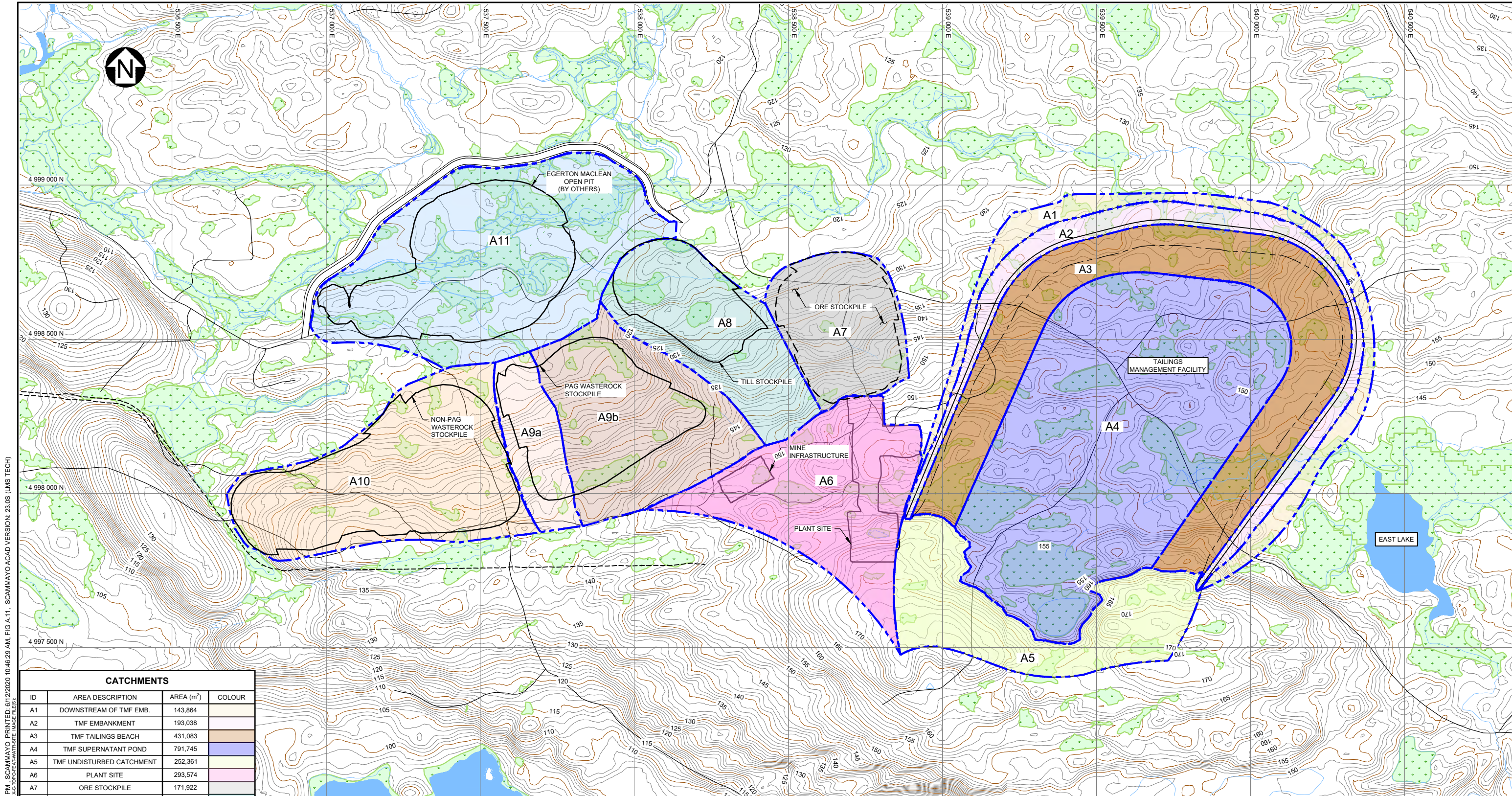

CATCHMENTS			
ID	AREA DESCRIPTION	AREA (m ²)	COLOUR
A1	DOWNSTREAM OF TMF EMB.	143,864	
A2	TMF EMBANKMENT	193,038	
A3	TMF TAILINGS BEACH	431,083	
A4	TMF SUPERNATANT POND	791,745	
A5	TMF UNDISTURBED CATCHMENT	252,361	
A6	PLANT SITE	293,574	
A7	ORE STOCKPILE	171,922	
A8	TILL AND TOPSOIL STOCKPILE	227,160	
A9a	PAG WASTE ROCK STOCKPILE	94,731	
A9b	PAG WASTE ROCK STOCKPILE	294,944	
A10	NON-PAG WASTE ROCK STOCKPILE	377,989	
A11	EGERTON MACLEAN OPEN PIT	495,562	

LEGEND:
 CATCHMENT BOUNDARY

- NOTES:**
- COORDINATE GRID IS NAD83, ZONE 20 T.
 - CONTOURS BASED ON 2014 LIDAR OBTAINED FROM GEONOVA, REPRODUCED AND DISTRIBUTED WITH THE PERMISSION OF INTERNAL SERVICES. CONTOURS HAVE BEEN PRODUCED BY KNIGHT PIESOLD LTD. AND INCLUDES DATA PROVIDED BY INTERNAL SERVICES. THE INCORPORATION OF DATA SOURCED FROM INTERNAL SERVICES WITHIN THIS PRODUCT SHALL NOT BE CONSTRUED AS CONSTITUTING AN ENDORSEMENT BY INTERNAL SERVICES OF OUR PRODUCT.
 - WETLAND AND WATER COURSE MAPPING PROVIDED BY McCALLUM ENVIRONMENTAL LTD. SEPTEMBER 06, 2018. DATA PROVIDED IN DRAFT WITH NO IMPLIED WARRANTIES AND SHALL BE CONSIDERED PRELIMINARY.
 - DIMENSIONS AND ELEVATIONS ARE IN METRES, UNLESS NOTED OTHERWISE.
 - LAYOUT IS FROM YEAR 7.

PLAN
SCALE A

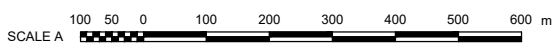

FOR INFORMATION ONLY

SAVED: M:\110100708\04\AAAcad\FIGS\B18_6\112020 3:45:19 PM - SCAMMAYO PRINTED: 6/12/2020 10:46:29 AM FIG A.11 - SCAMMAYO ACAD VERSION: 23.05 (LMS TECH)
 (P:\FILES\BND\CAD\110100708\04\AAAcad\FIGS\B18_6\112020 3:45:19 PM - SCAMMAYO PRINTED: 6/12/2020 10:46:29 AM FIG A.11 - SCAMMAYO ACAD VERSION: 23.05 (LMS TECH))

REV	DATE	DESCRIPTION	DESIGNED	DRAWN	REVIEWED
1	12JUN'20	ISSUED WITH REPORT	JEF	RMM/SC	DDF

ATLANTIC MINING NS CORP.	
FIFTEEN MILE STREAM PROJECT	
CATCHMENT AREA MAP YEAR 7	
	P/ANO. VA101-708/4 REF NO. 2 FIGURE A.11 REV 1

APPENDIX B

Design Basis and Operating Criteria

(Table B.1)

TABLE B.1

**ATLANTIC MINING NS CORP.
FIFTEEN MILE STREAM PROJECT**

**PRELIMINARY WASTE AND WATER MANAGEMENT DESIGN FOR EIS SUBMISSION
DESIGN BASIS AND OPERATING CRITERIA**

Print Jun/16/20 11:22:19

ITEM	CRITERIA	SOURCE
1.0	GENERAL	
1.1	Project Location	Located in central Nova Scotia, approximately 95 km northeast of Halifax near the eastern boundary of Halifax County. Situated east of Highway 374 and Fifteen Mile Stream and south of Seloam Lake (Sloane Reservoir).
1.2	Site Coordinates	UTM Coordinates 536,690 E and 4998795 N (Zone 20T, NAD83); Latitude 45°08'30" N, 62°32'00" W
1.3	Site Elevations	Ranging from approximately 100 to 175 meters above sea level (masl)
1.4	Codes and Guidelines	Nova Scotia Mineral Resources Regulations, Section 174, Regulation 222/2004, Canadian Dam Association Dam Safety Guidelines (2013, 2014), and related international best practice guidelines (currently no specific provincial dam safety legislation).
1.5	Climate	Mean Annual Precipitation (MAP) = 1,440 mm (falling as 83% rain and 17% snow) Long-Term Potential Evapotranspiration (PET) = 564 mm Actual Evapotranspiration (AET) = 340 to 450 mm (60 to 80% of PET)
1.6	Runoff Coefficients	Disturbed Areas (Roads, Dams, Stockpiles) = 0.85 Undisturbed Areas = 0.7 TMF Supernatant Pond = 1.0 TMF Tailings Beaches (Exposed) = 0.5 Open Pit = 0.9
1.7	Hydrometric	Mean Annual Unit Discharge (MAUD) = 31.8 L/s/km ² Mean Annual Unit Runoff (MAUR) = 1,000 mm Annual runoff coefficient for undisturbed areas = 0.7; should be refined for seasonal variances following site specific data collection and analysis.
1.8	24-hour Rainfall Events	1 in 2 year 24-hour rainfall = 75 mm 1 in 10 year 24-hour rainfall = 116 mm 1 in 100 year 24-hour rainfall = 168 mm 1 in 200 year 24-hour rainfall = 184 mm 1 in 1,000 year 24-hour rainfall = 219 mm Probable Maximum Precipitation (PMP) = 531 mm
1.9	Seismicity	1 in 100 year seismic event = 0.008 g 1 in 475 year seismic event = 0.027 g 1 in 1,000 year seismic event = 0.035 g 1 in 2,475 year seismic event = 0.061 g 1 in 5,000 year seismic event = 0.088 g 1 in 10,000 year seismic event = 0.129 g Maximum Credible Earthquake Magnitude = 7.2 (1929, 500 km distance)
2.0	MINE PRODUCTION SCHEDULE	
2.1	Ore	Total Ore Milled = 13.4 Million tonnes (Mt) Nominal mill throughput = 2 Mt/year (approximately 5,500 tpd) Mine Life = 7 years Year -1 = 0.1 Mt, Year 1 = 1.9 Mt, Year 2 to 6 = 2 Mt, Year 7 = 1.4 Mt Ore processing by gravity separation and flotation on site to produce a gold concentrate. Concentrate is shipped to the Touquoy facility for final processing.
2.2	Tailings	Total tailings production = 13.4 Mt Initial settled dry density = 1.3 t/m ³ ; Specific gravity of solids = 2.79
2.3	Waste Rock	Total mined = 24.4 Mt Non-PAG waste rock used to construct TMF embankment with balance stored in on-land stockpile. PAG and Non-PAG waste rock segregated in separate stockpiles. PAG waste rock stored in on-land stockpile. PAG and Non-PAG waste rock segregated in separate stockpiles. Dry density (compacted) = 2.2 t/m ³ ; Specific Gravity of solids = 2.79
2.4	Till & Overburden	Total mined = 2.1 Mt Stored in on-land dump or used TMF embankment construction, if appropriate. Dry density (compacted) = 2.0 t/m ³
2.5	Topsoil	Total mined = 0.2 Mt; Stored in on-land stockpiles. Used in reclamation at end of mine life.

TABLE B.1
**ATLANTIC MINING NS CORP.
 FIFTEEN MILE STREAM PROJECT**
**PRELIMINARY WASTE AND WATER MANAGEMENT DESIGN FOR EIS SUBMISSION
 DESIGN BASIS AND OPERATING CRITERIA**

Print Jun/16/20 11:22:19

ITEM	CRITERIA	SOURCE
3.0	TAILINGS MANAGEMENT FACILITY	
3.1	Function	Secure, long-term storage of approximately 13.4 Mt of tailings and associated water management. Knight Piésold Ltd., MMTS
3.2	Concept	Zoned earthfill/rockfill embankment constructed in stages using downstream method of construction. Knight Piésold Ltd.
		Embankment upstream face lined with compacted fine-grained earthfill (sourced from local drumlin borrows) with appropriately graded filter zones to prevent migration of fine particles downstream. Knight Piésold Ltd.
		Rockfill for initial construction and staged raises provided from mining the open pit. Knight Piésold Ltd. / Moose Mountain Technical Services
3.3	Operational Criteria	Mill throughput (tailings production rate): 5,500 tpd Knight Piésold Ltd.
		Runoff from storm events not exceeding the EDF contained within tailings impoundment. Return periods exceeding the EDF safely conveyed from TMF through emergency discharge spillway. Knight Piésold Ltd.
		Available water from TMF recycled to mill to the maximum extent possible for use in the process of tailings. Knight Piésold Ltd.
3.4	Closure Criteria	Downstream embankment slopes will be reclaimed with topsoil and revegetated. Knight Piésold Ltd.
		Closure Cover consisting of fill and waste rock materials to grade tailings surface at closure and facilitate runoff through breach in TMF embankment, and establish flow pathway to the Egerton-Maclean Open Pit. Exposed, erodible surfaces will be revegetated and a seasonal wetland implemented. Knight Piésold Ltd.
3.5	Dam Hazard Classification	The TMF has a HIGH classification as defined by the Canadian Dam Association (CDA) "Dam Safety Guidelines" (2013) and CDA Technical Bulletin "Application of Dam Safety Guidelines to Mining dams" (2014). Knight Piésold Ltd.
3.6	Storage Capacity	Tailings Solids plus Entrained Water: 10.3 Mm ³ Knight Piésold Ltd.
		Maximum Supernatant Pond Water: 800,000 m ³ Knight Piésold Ltd.
		Environmental Design Flood (EDF): 640,000 m ³ Knight Piésold Ltd.
3.7	Tailings Properties	Average Tailings Settled Dry Density = 1.3 t/m ³ Knight Piésold Ltd.
		Tailings Specific Gravity = 2.79 Knight Piésold Ltd.
		Tailings Solids Content = 38% w/w Knight Piésold Ltd.
3.8	Environmental Design Flood (EDF)	EDF specified as the largest design flood event that can be safely stored within the facility, typically between a 1 in 50 year and a 1 in 200 year precipitation event. Knight Piésold Ltd., Canadian Dam Association
		EDF = 1 in 200 year 24 hr precipitation event plus estimated maximum monthly precipitation across entire TMF catchment Knight Piésold Ltd.
		TMF Catchment Area = 121 Ha Knight Piésold Ltd.
		EDF Volume = ((1 in 200 year 24 hr precipitation event + max. monthly precipitation) x TMF Catchment Area) = 640,000 m ³ Knight Piésold Ltd.
3.9	Inflow Design Flood (IDF)	For a HIGH dam classification, an IDF of 1/3 between the 1/1,000-year return period event and the Probable Maximum Flood (PMF) is recommended during operations, and 2/3 between the 1/1,000-year return period event and the PMF post-closure. Knight Piésold Ltd., CDA (2013, 2014)
		IDF will be passed through TMF emergency discharge spillway, located on the western abutment of the TMF embankment. The spillway will convey flows exceeding the EDF to Seloam Brook. Knight Piésold Ltd.
3.10	Design Freeboard	Sufficient freeboard to accommodate the EDF above the maximum supernatant pond level at each stage of development, plus 2 meter allowance for wave run-up protection, ice depth, and seismic settlement below the invert of the emergency discharge spillway. Knight Piésold Ltd.
3.11	Dam Crest	Dam Crest Width: Minimum 7.5 m between safety berms of one-way haul truck access Knight Piésold Ltd. Minimum 4 m staged crest raise to allow for sufficient working surface for haul truck access Knight Piésold Ltd.
3.12	Seepage and Runoff Control Measures	Seepage will be primarily controlled through the use of a low-permeability till liner on the upstream embankment face, and partial lining of the TMF basin. Knight Piésold Ltd.
		A system of collection ditches, ponds, and pumpback systems downstream of embankments will collect seepage and runoff from the TMF. Knight Piésold Ltd.
		Toe drain installed at upstream toe of TMF embankment to control seepage through the TMF embankment and maintain phreatic surface through the embankment. Knight Piésold Ltd.
		Flows collected in seepage collection ponds and toe drain will be recycled to the TMF supernatant pond. Knight Piésold Ltd.
3.13	Embankment Slopes	Embankment slopes constructed to a maximum slope of 2.5H:1V on the upstream face to facilitate till liner construction, and 2H:1V on the downstream side for reclamation purposes and to achieve the minimum required Factors of Safety (FOS _{min}) for static and seismic loading conditions. Knight Piésold Ltd.

TABLE B.1

**ATLANTIC MINING NS CORP.
FIFTEEN MILE STREAM PROJECT**

**PRELIMINARY WASTE AND WATER MANAGEMENT DESIGN FOR EIS SUBMISSION
DESIGN BASIS AND OPERATING CRITERIA**

Print Jun/16/20 11:22:19

ITEM		CRITERIA	SOURCE	
3.14	Embankment Stability	End of Construction (Starter Dam and Dam Raises)	FOS _{min} = 1.5	CDA (2013, 2014)
		Long-Term, Steady State Conditions (At Closure)	FOS _{min} = 1.5	CDA (2013, 2014)
		Seismic (Pseudo-Static Loading Conditions)	FOS _{min} = 1.0	CDA (2013, 2014)
		Seismic (Post-earthquake; full tailings liquefaction)	FOS _{min} = 1.2	CDA (2013, 2014)
3.15	Starter (Stage 1) Dam	Stage 1 Starter Dam sized to provide approx. 12 months of tailings storage and sufficient water during construction to commence operations.	Knight Piésold Ltd.	
3.16	Staged Expansion Construction Method	Stage 2 embankment raise constructed during first year of operations.	Knight Piésold Ltd.	
		TMF embankments progressively raised throughout operations.	Knight Piésold Ltd.	
		Minimum 4 m staged crest raise to allow for sufficient working surface for haul truck access	Knight Piésold Ltd.	
		Embankment raises constructed using downstream method of construction.	Knight Piésold Ltd.	
3.17	Embankment Construction Materials	Low-permeability till liner on upstream face of embankment, and partial coverage in TMF basin.	Knight Piésold Ltd.	
		Filter and transition zones - Processed from pit-run material or from local borrow/quarry sources	Knight Piésold Ltd.	
		Shell Zone Material - pit-run material or blast rock from local borrow	Knight Piésold Ltd.	
		Rockfill layer on top of low-permeability till liner for ice and erosion protection	Knight Piésold Ltd.	
4.0 TAILINGS DISTRIBUTION AND RECLAIM SYSTEMS				
4.1	Tailings Stream	Tailings Design Production Rate (tph) = 230 tph (5,500 tpd)	Knight Piésold Ltd.	
		Tailings Specific Gravity of Solids = 2.79	Knight Piésold Ltd.	
		Tailings Percent Solids (%) = 38% (wt/wt)	Knight Piésold Ltd.	
		Plant Site Availability = 90%	Knight Piésold Ltd.	
4.2	Tailings	Single stream discharge of tailings material from Process Plant	Knight Piésold Ltd.	
		One overland, pressure tailings delivery pipeline along embankment crests. Pipeline capacity = 100% tailings production rate.	Knight Piésold Ltd.	
		Tailings discharge spigots at typical spacing along TMF embankments	Knight Piésold Ltd.	
		Tailings pipeline pressure surge capacity = 20%	Knight Piésold Ltd.	
		Tailings pipeline specification - HDPE, PE4710, maximum pressure rating DR21, minimum pressure rating DR9. Steel to be used only if required when pressure exceeds 250 psi. Steel schedule to be selected based on pressure performance requirement.	Knight Piésold Ltd.	
		Tailings pumped from pump box at Plant Site to TMF for delivery.	Knight Piésold Ltd.	
4.3	Reclaim	Single overland reclaim delivery pipeline from TMF to Process Plant.	Knight Piésold Ltd.	
		Reclaim pump - skidder pumps with standby pumps in case of system shutdown.	Knight Piésold Ltd.	
		Reclaim pumps to be moveable along TMF Reclaim Causeway to reclaim from deepest point of supernatant pond.	Knight Piésold Ltd.	
		Reclaim pump design flowrate = 100% of tailings process water requirements.	Knight Piésold Ltd.	
		Reclaim pipeline discharge flange connection elevation: 170 m (Process Plant pad elevation + assumed 10 m for water tank)	Knight Piésold Ltd.	
		Reclaim pipeline specification - HDPE, PE4710, maximum pressure rating DR21, minimum pressure rating DR9. Steel to be used only if required when pressure exceeds 250 psi. Steel schedule to be selected based on pressure performance requirement.	Knight Piésold Ltd.	
		Reclaim pipeline alignment adjacent to access/maintenance roads where available.	Knight Piésold Ltd.	
4.4	Surplus Water	Reclaim pipeline pressure surge capacity = 20%	Knight Piésold Ltd.	
		Single overland reclaim delivery pipeline from TMF to Water Treatment Plant (WTP).	Knight Piésold Ltd.	
		Surplus water pump - skidder pumps with standby pumps in case of system shutdown.	Knight Piésold Ltd.	
		Surplus water pumps to be moveable along TMF Reclaim Causeway to reclaim from deepest point of supernatant pond.	Knight Piésold Ltd.	
		Surplus water pump design flowrate = 385 m ³ /hr average	Knight Piésold Ltd.	
		Surplus water pump flowrate variability: maximum 515 m ³ /hr for varying climatic conditions	Knight Piésold Ltd.	
		Surplus water reclaim pipeline discharge flange connection elevation: 170 m (WTP pad elevation + assumed 10 m for water tank)	Knight Piésold Ltd.	
		Surplus water discharge pipeline via gravity discharge to Anti Dam Flowage. Discharge El. 100 m	Knight Piésold Ltd.	
		Surplus water pipeline specification - HDPE, PE4710, maximum pressure rating DR21, minimum pressure rating DR9. Steel to be used only if required when pressure exceeds 250 psi. Steel schedule to be selected based on pressure performance requirement.	Knight Piésold Ltd.	
		Surplus water pipeline alignment adjacent to access/maintenance roads where available.	Knight Piésold Ltd.	
Surplus water pipeline pressure surge capacity = 20%	Knight Piésold Ltd.			

TABLE B.1

**ATLANTIC MINING NS CORP.
FIFTEEN MILE STREAM PROJECT**

**PRELIMINARY WASTE AND WATER MANAGEMENT DESIGN FOR EIS SUBMISSION
DESIGN BASIS AND OPERATING CRITERIA**

Print Jun/16/20 11:22:19

ITEM	CRITERIA	SOURCE
5.0 WATER MANAGEMENT		
5.1	Water Management Objectives	Utilise water within the project area to the maximum extent with no untreated contact water discharged from site under normal operating conditions. Knight Piésold Ltd. Divert undisturbed area runoff around the site as much as practicable. Knight Piésold Ltd. Diversion ditches and collection ponds sized for the 1-in-200 year 24-hr precipitation event. Knight Piésold Ltd. Minimize surface disturbances using staged construction and maximize concurrent reclamation. Knight Piésold Ltd. Collect seepage through and beneath the TMF embankments and runoff from the downstream embankment face. Knight Piésold Ltd. Collect and recycle runoff from disturbed areas or evaporate. Knight Piésold Ltd. Maximize recycle of water from TMF pond for process water. Knight Piésold Ltd.
5.2	TMF Supernatant Pond	Collects water from mill process and site water management ponds, precipitation, and undiverted runoff for recycle to the mill. Knight Piésold Ltd. Water pumped to mill for reclaim, with surplus water pumped to water treatment plant for treatment and discharge to the environment, if required. Knight Piésold Ltd. Sized to contain 100% of water in tailings (assumed three months of total mill water requirements). Knight Piésold Ltd. Contingency storage for an EDF event above maximum operating pond volume. Knight Piésold Ltd. Overflow discharge to emergency discharge spillway in the event of a large flood event exceeding the EDF for the TMF. Knight Piésold Ltd.
5.3	Seepage Collection and Recycle Ponds	Collects runoff from the TMF embankment, seepage from the TMF embankment and TMF toe drain, and undiverted runoff from contributing catchment areas. Knight Piésold Ltd. Sized to contain runoff and precipitation from the 1-in-200 year 24 hr precipitation event in addition to design flows. Knight Piésold Ltd. Water pumped to TMF supernatant pond to be reclaimed to mill through TMF Reclaim Water System. Knight Piésold Ltd.
5.4	Diversion Channels	Collects non-contact water and diverts around site components to the maximum practical extent. Knight Piésold Ltd. Designed for the 1 in 200 year precipitation event peak flows Knight Piésold Ltd. Armoured or lined with riprap, as required. Knight Piésold Ltd.
5.5	Seloam Brook Realignment	Realigns Seloam Brook around proposed Open Pit. Knight Piésold Ltd. Sized for Seloam Brook peak flows. Knight Piésold Ltd. Fish habitat and remediation as required. Knight Piésold Ltd. Armoured or lined with riprap, as required. Knight Piésold Ltd.
6.0 INSTRUMENTATION AND MONITORING		
6.1	Geotechnical Instrumentation and Monitoring	Vibrating wire piezometers to measure pore water pressure in embankment, foundation, and tailings mass. Knight Piésold Ltd. Pond level indicator in TMF supernatant pond. Knight Piésold Ltd. Inclometers as required. Knight Piésold Ltd. Water management pond inflow weirs. Knight Piésold Ltd. Survey and surface movement monitoring monuments. Knight Piésold Ltd. Flow monitoring for toe drains and diversion channels. Knight Piésold Ltd. Groundwater quality monitoring stations upstream and downstream of all contact water sources. Knight Piésold Ltd.

TABLE B.1

**ATLANTIC MINING NS CORP.
FIFTEEN MILE STREAM PROJECT**

**PRELIMINARY WASTE AND WATER MANAGEMENT DESIGN FOR EIS SUBMISSION
DESIGN BASIS AND OPERATING CRITERIA**

Print Jun/16/20 11:22:19

ITEM		CRITERIA	SOURCE
7.0 CLOSURE AND RECLAMATION OBJECTIVES			
7.1	Physical Stability Objectives	Ensure long-term physical stability to protect public safety and reduce erosion and downstream sedimentation - Remaining structures, such as TMF, will be physically stable in the long-term - All spillways will be designed by a professional engineer in accordance with the CDA Dam Safety Guidelines, and installed prior to final decommissioning of the TMF - Monitoring will be undertaken to demonstrate that reclamation and environmental protection objectives, including stability of structures, are being achieved.	Knight Piésold Ltd.
7.2	Chemical Stability Objectives	Meet applicable water quality standards in the receiving environment by promoting long-term chemical stability of the tailings. - Prediction will be completed on potential metal leaching (ML) and/or acid rock drainage (ARD) materials to compile a material inventory of ML/ARD. - Monitoring will be undertaken to demonstrate that reclamation and environmental protection objectives, including water quality, are being achieved.	Knight Piésold Ltd.
7.3	Future Use and Aesthetics	Create a final landform compatible with the surrounding landscape and consistent with the agreed upon post-closure land use. - The TMF will be reclaimed in a manner consistent with adjacent landforms and to the approved land use. - Lands (including the TMF) will be revegetated to a self-sustaining state using appropriate plant species, and growth mediums used will satisfy land use, capability and water quality objectives. - All machinery, equipment, and building superstructures will be removed, concrete foundations covered and revegetated, and scrap material disposed of in a manner acceptable to an inspector. - Monitoring will be undertaken to demonstrate that reclamation and environmental protection objectives, including land use and productivity, are being achieved.	Knight Piésold Ltd.

M:\110100708\04\A\Data\Design Basis[Design Basis Table_r1.xlsx]Table B.1

1	12JUN20	ISSUED WITH REPORT VA101-708/4-2	JEF	DDF
REV	DATE	DESCRIPTION	PREP'D	RW'D

APPENDIX C

Updated Seismic Design Parameters (KP, 2019)

(Pages C-1 to C-6)

MEMORANDUM

Date: April 5, 2019 **File No.:** VA101-00708/04-A.01
Cont. No.: VA18-02372

To: Mr. Alastair Tiver

Copy To: James Millard, Meghan Milloy (McCallum Environmental)

From: Graham Greenaway

Re: **Moose River Consolidated Phase II – Updated Seismic Design Parameters**

1.0 INTRODUCTION

Atlantic Gold Corporation is in the early stages of developing the Moose River Consolidated Phase II Expansion located approximately 100 km north-east of Halifax, in central Nova Scotia. The Expansion comprises two mine sites: the Fifteen Mile Stream Project and the Cochrane Hill Project (the Projects). Knight Piésold Ltd. (KP) previously completed a review of the regional seismicity at the Cochrane Hill and Fifteen Mile Stream Projects (the Projects) in order to provide seismic design parameters (KP, 2018). Both projects are located in the province of Nova Scotia in Canada within 50 km of each other. The mine sites locations have been defined by the following global coordinates:

- Cochrane Hill Project (Latitude 45.25° and Longitude -62.0°)
- Fifteen Mile Stream Project (Latitude 45.14° and Longitude -62.53°)

Recommended seismic parameters were provided for design of the Tailings Management Facility (TMF) and other structures required at the project sites using the National Building Code of Canada (2015). Site-specific seismic ground motion parameters were determined for the project sites using the probabilistic seismic hazard database of Natural Resources Canada (NRC). The results included the peak horizontal ground accelerations (PGAs) and spectral accelerations for earthquake events having return periods from 100 years to 2,475 years (the maximum return period provided by NRC).

For future design studies, it was recommended that a site-specific probabilistic seismic hazard analysis be carried out to provide seismic parameters for return periods of up to 10,000 years. This has been conducted using the seismic hazard analysis program EZ-FRISK. The results of the analysis are provided in this memo.

2.0 REGIONAL TECTONICS AND SEISMICITY

Eastern Canada is located in a stable continental region within the North American tectonic plate and has a relatively low rate of seismic activity. However, moderate to large earthquakes have occurred in the region and can be expected in the future. In eastern Canada, earthquakes are believed to be primarily caused by a northeast-to-east oriented compressive stress field reactivating zones of crustal weakness – either failed rifts or old fault zones (Cassidy et al., 2010).

Historical seismic data recorded throughout eastern Canada has identified clusters of earthquake activity. The historical seismicity of Nova Scotia and surrounding regions is shown on Figure 1. The historical earthquake data is provided by the National Resources Canada since 1985; however, Figure 1 also includes other significant large magnitude earthquakes that have occurred in the surrounding region.

A Magnitude (M) 5.4 earthquake occurred in 1982 in the north-central Miramichi Highlands, New Brunswick, within the Northern Appalachians seismic zone (Adams and Halchuk, 2003; Halchuk et al., 2015). The main shock was followed by numerous strong aftershocks. A Magnitude 7.2 earthquake occurred offshore in 1929 near the Atlantic margin at about 250 km south of Newfoundland along the southern edge of the Grand Banks within the Laurentian Slope seismic zone (Adams and Halchuk, 2003; Halchuk et al., 2015). This earthquake was felt as far away as New York and Ottawa, and triggered a large tsunami (seismic sea-wave) caused by a large submarine slump (estimated at 200 km³ of material). The tsunami caused flooding and loss of life when it came ashore on the Burin Peninsula in southern Newfoundland (Cassidy et al., 2010). The two project sites are located approximately 400 km away from the 1982 M5.4 earthquake and more than 500 km away from the 1929 M7.2 earthquake. The historical seismic activity near the project sites is low.

The Charlevoix seismic zone, which is the most seismically active region of eastern Canada, is located about 100 km downstream from Quebec City. Most earthquakes in this zone occurred under the St. Lawrence River between Charlevoix County on the north shore and Kamouraska County on the south shore with five large earthquakes (M 5.9 to 7.0) occurring since 1663. The most recent large earthquake in this seismic zone occurred in 1925 (M 6.2) and the largest occurred in 1663 (M 7.0). The project sites are located more than 600 km away from the Charlevoix seismic zone. The seismic hazard at the project sites due to future earthquakes in this zone would be very low due to attenuation over such a large distance.

3.0 SEISMIC HAZARD ANALYSIS

The seismic ground motion parameters determined for the Projects using the probabilistic seismic hazard database of Natural Resources Canada (NRC) are calculated using the Seismic Hazard Model of Canada, developed to provide seismic design values for the 2015 NBCC (Adams et al, 2015; Halchuk et al., 2015). Peak horizontal ground accelerations (PGAs) and spectral accelerations (5% damping) for earthquake events having return periods of 100 years, 475 years, 1,000 years and 2,475 years are provided by the NRC database. The PGA values and spectral accelerations for each of these return periods are provided in Table 1.

The computer program EZ-FRISK (Risk Engineering, Inc.) has been used to develop a seismic hazard model for Nova Scotia and the surrounding regions of Eastern Canada. The seismic hazard analysis module available with EZ-FRISK includes a database provided by Risk Engineering Inc. of faults and areal seismic sources for the pertinent regions of Eastern Canada. Magnitude-frequency recurrence relationships and the corresponding maximum earthquake magnitude for each seismic source are prepared by Risk Engineering from consideration of historical seismicity, fault characteristics and the regional tectonics. The model has been developed to be consistent with the Seismic Hazard Model of Canada developed for NBCC 2015.

Appropriate ground motion attenuation models defining the relationship between earthquake magnitude, source to site distance and peak ground motion (acceleration) are required to carry out the probabilistic seismic hazard analysis. The ground motions experienced at the Projects are dependent on the regional ground motion attenuation characteristics and the earthquake source mechanism. Spectral acceleration values, required for development of design response spectra, are also estimated using the attenuation relationships. A suite of relations based on the ground motion values provided by five appropriate eastern ground motion models is used in the Seismic Hazard Model of Canada (Atkinson and Adams, 2013). These relations have also been used in this study to define the ground motion attenuation characteristics in the EZ-FRISK model.

The seismic hazard model developed using EZ-FRISK has been used to determine PGA and spectral acceleration values for return periods from 100 years to 10,000 years. The calculated values for return periods up to 2,475 years are in excellent agreement with the values provided by NRC. PGA and spectral accelerations provided by the EZ-FRISK model for longer return periods of 5,000 years and 10,000 years are included in Table 1.

The PGA and spectral acceleration values presented in Table 1 correspond to a reference ground condition of Site Class C with an average shear wave velocity V_{s30} of 450 m/s (defined by the National Building Code of Canada as very dense soils or soft rock). Appropriate factors will need to be applied to these values to account for seismic site response, based on consideration of site specific conditions and information provided by in situ test data obtained from geotechnical site investigations.

Deaggregation of the probabilistic seismic hazard results from the EZ-FRISK model has been carried out to provide the relative contributions of all potential seismic sources, and to more accurately define the characteristics of design earthquakes required for the seismic design of the TMF and other critical project facilities. The required characteristics of the design earthquake events include Magnitude and frequency characteristics (defined by response spectra). Specifically, the average earthquake Magnitude (mode and mean values) associated with each return period have been calculated. Magnitude values were also calculated for short period motions (defined by PGA and $S_a(0.2)$ values) and long period motions (defined by $S_a(1.0)$ values). The results indicate that the Magnitude does not change significantly with return period or between short period and long period motions. Consequently, it is recommended that a design earthquake Magnitude of 7.25 be adopted for return periods ranging from 475 years to 10,000 years.

4.0 SUMMARY

Site-specific seismic ground motion parameters had been determined previously for the Projects using the probabilistic seismic hazard database of Natural Resources Canada. The results are summarized in Table 1 in terms of earthquake return period, probability of exceedance (in 50 years) and the corresponding horizontal PGA and spectral accelerations (5% damping) for earthquake events having return periods of 100 years, 475 years, 1,000 years, and 2,475 years. The PGA for a return period of 475 years is only 0.022 g, indicating the projects are located in a region of low seismic hazard.

A site-specific probabilistic seismic hazard model has been developed using the EZ-FRISK program to provide PGA and spectral accelerations for longer return periods of 5,000 years and 10,000 years. Calculated values are included in Table 1. An earthquake Magnitude of 7.25 is recommended for seismic design studies, based on a deaggregation analysis of the probabilistic seismic hazard results provided by the EZ-FRISK model.

We trust this meets your needs at this time. Please contact the undersigned with any questions.

Yours truly,
Knight Piésold Ltd.



Prepared:

Graham Greenaway, MSc., P.Eng.
Specialist Geotechnical Engineer

Reviewed:



Daniel Fontaine, P.Eng.
Specialist Engineer | Associate

Approval that this document adheres to the Knight Piésold Quality System:

DDF

Attachments:

Table 1 Rev 0 Summary of Seismic Design Parameters
Figure 1 Rev 0 Historical Seismicity of Nova Scotia and Surrounding Regions

References:

- Adams, J. and Halchuk, S., (2003) "Fourth generation seismic hazard maps of Canada: Values for over 650 Canadian localities intended for the 2005 National Building Code of Canada", Geological Survey of Canada, Open File 4459.
- Adams, J., Halchuk, S., Allen, T. & Rogers, G. (2015) "Canada's 5th Generation seismic hazard model, as prepared for the 2015 National Building Code of Canada", Canadian Conference on Earthquake Engineering, Victoria, Canada, Paper 93775.
- Atkinson, G.M. & Adams, J. (2013) "Ground motion prediction equations for application to the 2015 Canadian national seismic hazard maps", Canadian Journal of Civil Engineering, Vol.40, No. 10, p988-998.
- J.F. Cassidy, G.C. Rogers, M. Lamontagne, S. Halchuk, and J. Adams, (2010), "Canada's Earthquakes: The Good, the Bad and the Ugly", GeoScience Canada, 2010, Volume 37 Number 1.
- Halchuk, S.C., Adams, J.E., and Allen, T.I., 2015. Fifth Generation Seismic Hazard Model for Canada: Grid values of mean hazard to be used with the 2015 National Building Code of Canada; Geological Survey of Canada, Open File 7893.
- Knight Piésold Ltd. (KP, 2018). Cochrane Hill and Fifteen Mile Stream Projects – Seismic Design Parameters (KP Reference No. VA18-00160), March 5, 2018.
- Natural Resources Canada (NRC). 2015 National Building Code Seismic Hazard Calculation. Retrieve from: <http://earthquakescanada.nrcan.gc.ca/hazard-alea/zoning/haz-eng.php> (accessed November 21, 2017).

/grg

TABLE 1

ATLANTIC GOLD CORPORATION
MOOSE RIVER CONSOLIDATED PHASE II

SUMMARY OF SEISMIC DESIGN PARAMETERS

Print Apr/05/19 11:37:49

Return Period (Years)	Probability of Exceedance in 50 Years (%)	Spectral Acceleration (g)									Peak Ground Acceleration (g)
		Sa(0.05)	Sa(0.1)	Sa(0.2)	Sa(0.3)	Sa(0.5)	Sa(1.0)	Sa(2.0)	Sa(5.0)	Sa(10.0)	
100	40%	0.008	0.014	0.017	0.016	0.014	0.008	0.004	0.001	0.001	0.008
475	10%	0.025	0.038	0.042	0.039	0.036	0.023	0.012	0.003	0.001	0.022
1,000	5%	0.041	0.060	0.063	0.058	0.052	0.034	0.018	0.005	0.002	0.035
2,475	2%	0.075	0.105	0.104	0.092	0.079	0.051	0.028	0.008	0.003	0.061
5,000	1%	0.113	0.153	0.148	0.127	0.108	0.070	0.039	0.011	0.004	0.088
10,000	0.5%	0.171	0.225	0.210	0.177	0.146	0.092	0.051	0.015	0.006	0.129

M:\1\01\00708\04\A\Correspondence\VA18-02372 - Updated Seismic Design Parameters\Attachments\[Table 1 -Revised Seismic Design Parameters.xlsx]Table 1

NOTES:

1. PROBABILITY OF EXCEEDANCE CALCULATED FOR A DESIGN LIFE OF 50 YEARS.

$$q = 1^{-L/T}$$

WHERE: q = PROBABILITY OF EXCEEDANCE

L = DESIGN LIFE IN YEARS

T = RETURN PERIOD IN YEARS

2. SPECTRAL AND PEAK GROUND ACCELERATIONS FOR RETURN PERIODS UP TO 2,475 YEARS OBTAINED FROM THE SEISMIC HAZARD DATABASE OF NATURAL RESOURCES CANADA. SPECTRAL AND PEAK GROUND ACCELERATIONS FOR RETURN PERIODS OF 5,000 AND 10,000 YEARS CALCULATED USING EZ-FRISK.

3. SPECTRAL AND PEAK GROUND ACCELERATIONS ARE HORIZONTAL GROUND MOTIONS FOR "FIRM GROUND" (SITE CLASS C) WITH SHEAR WAVE VELOCITY V_{s30} OF 450 M/S, AS DEFINED BY THE NATIONAL BUILDING CODE OF CANADA (2015).

4. VALUES OF SPECTRAL AND PEAK GROUND ACCELERATION SHALL BE USED TO 2 SIGNIFICANT FIGURES.

0	05APR'19	ISSUED WITH MEMO VA18-02372	GRG	DDF
REV	DATE	DESCRIPTION	PREP'D	RVW'D

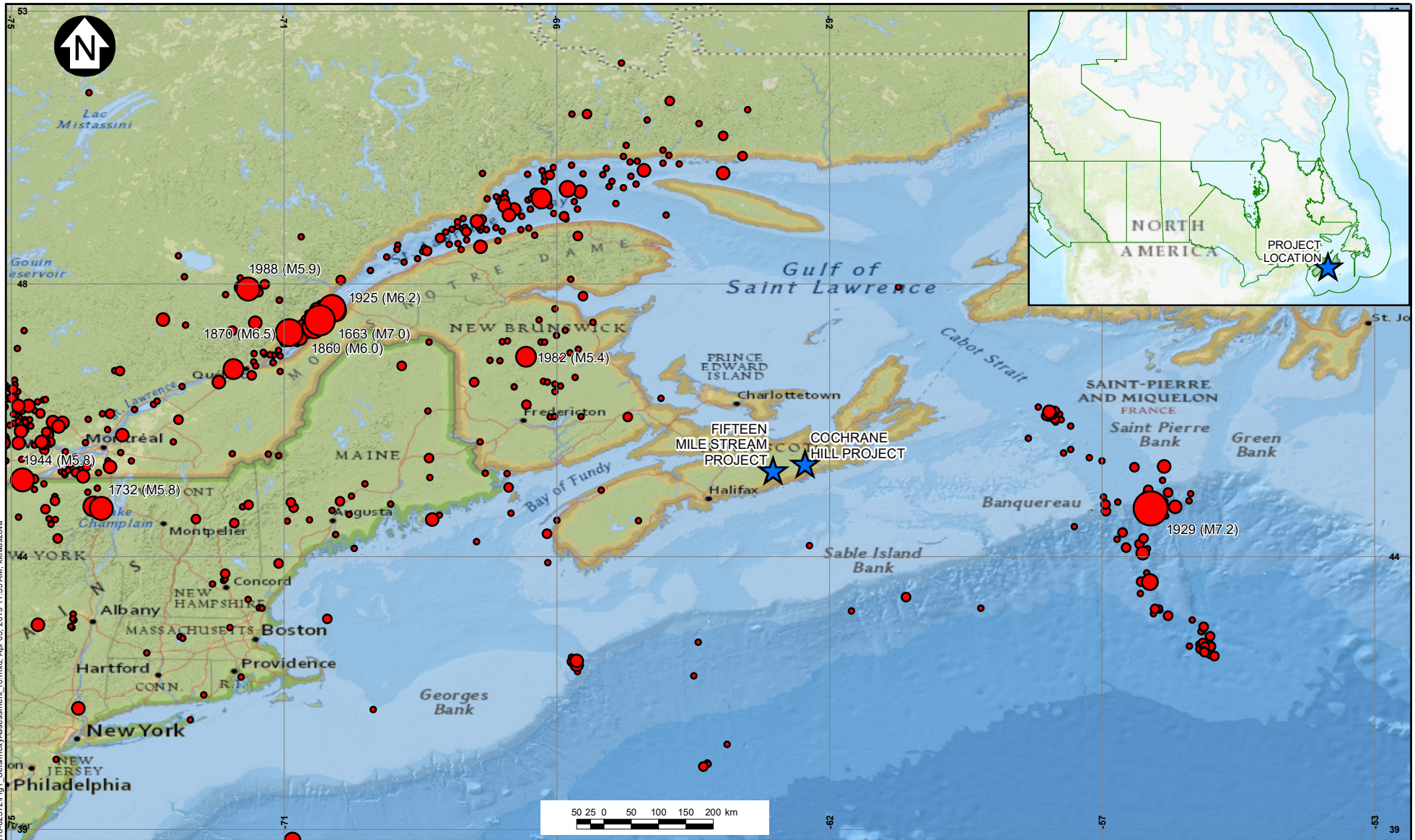

SAVED: M:\1010070804\GIS\Figs\VA18-02372\Fig1_SeismicityAssessment_0.mxd; Apr 05, 2019 11:55 AM; kkrauszova

LEGEND:

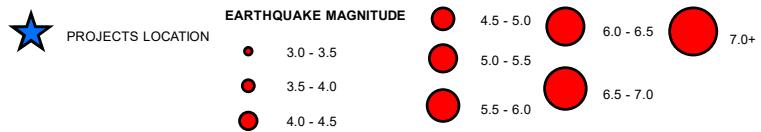

NOTES:

1. HISTORICAL EARTHQUAKE DATA PROVIDED BY THE NRCAN DATABASE SINCE 1985. ADDITIONAL LARGE MAGNITUDE EARTHQUAKES RECORDED IN 1663, 1732, 1860, 1870, 1925, 1929, 1944, AND 1982 ARE INCLUDED.
2. EARTHQUAKE DATA PROVIDED BETWEEN LATITUDE 52° AND 39°, AND LONGITUDE -55° AND -75°.
3. BASE MAP: ESRI WORLD STREET MAP.
4. COORDINATE GRID IS IN METRES. COORDINATE SYSTEM: GCS WGS 1984.
5. THIS FIGURE IS PRODUCED AT A NOMINAL SCALE OF 1:10,000,000 FOR 8.5x11 (LETTER) PAPER. ACTUAL SCALE MAY DIFFER ACCORDING TO CHANGES IN PRINTER SETTINGS OR PRINTED PAPER SIZE.

ATLANTIC GOLD CORPORATION

MOOSE RIVER CONSOLIDATED PHASE II

HISTORICAL SEISMICITY OF NOVA SCOTIA AND SURROUNDING REGIONS

REV	DATE	ISSUED WITH MEMORANDUM	DESCRIPTION	DESIGNED	DRAWN	REVIEWED
0	05APR19	ISSUED WITH MEMORANDUM		KK	KK	AS2



PRJ NO. VA101-708/4	REF NO. VA18-02372
FIGURE 1	
	REV 0

APPENDIX D

Water Balance Inputs, Assumptions and Results

- Appendix D1 Climate Inputs
- Appendix D2 Water Balance Inputs
- Appendix D3 Operational Water Balance Results
- Appendix D4 Closure Water Balance Results

APPENDIX D1

Climate Inputs

(Tables D1.1 to D1.3)

TABLE D1.1

**ATLANTIC MINING NS CORP.
FIFTEEN MILE STREAM PROJECT**

TOTAL MONTHLY PRECIPITATION TIME SERIES

Print Jun/11/20 9:20:58

Year	Precipitation (mm)												Total
	Jan	Feb	Mar	Apr	May	Jun	Jul	Aug	Sep	Oct	Nov	Dec	
1961	122	91	71	128	136	78	38	92	54	165	149	187	1,311
1962	159	147	76	190	47	98	146	158	155	181	243	180	1,780
1963	208	179	90	129	122	60	49	152	150	71	180	169	1,559
1964	184	184	130	128	69	78	190	120	101	122	120	280	1,706
1965	137	173	49	70	26	95	56	118	18	83	141	84	1,050
1966	88	66	160	30	117	55	51	82	128	129	90	128	1,124
1967	113	119	135	94	197	64	95	163	143	185	192	223	1,723
1968	134	79	116	70	102	120	8	48	66	93	214	186	1,236
1969	198	148	102	145	58	46	102	50	90	66	245	198	1,448
1970	28	94	109	98	112	96	83	178	79	121	129	209	1,336
1971	112	189	182	102	230	41	66	387	68	95	191	114	1,777
1972	153	182	245	145	174	132	128	84	50	195	268	177	1,933
1973	112	161	106	156	105	158	152	170	34	131	74	171	1,530
1974	85	206	136	99	120	110	57	76	161	113	143	129	1,435
1975	209	60	175	109	61	68	71	35	93	141	155	295	1,472
1976	164	121	91	67	142	59	132	77	122	179	100	240	1,494
1977	134	107	96	83	70	181	164	97	130	197	95	197	1,551
1978	313	61	103	131	56	93	61	17	80	140	50	121	1,226
1979	234	131	197	138	134	66	171	162	82	169	216	182	1,882
1980	101	32	173	199	77	107	70	31	110	118	153	162	1,333
1981	182	90	113	81	180	137	148	100	110	144	187	278	1,750
1982	205	81	105	183	57	92	135	104	106	28	122	119	1,337
1983	135	110	185	159	132	53	121	161	83	83	196	157	1,575
1984	195	142	184	165	142	80	51	97	65	50	37	137	1,345
1985	65	106	122	81	111	307	67	141	31	65	113	89	1,298
1986	178	89	130	139	99	91	138	127	131	75	160	113	1,470
1987	166	42	81	130	75	97	61	65	136	147	157	178	1,335
1988	110	170	79	228	53	88	190	68	73	235	197	63	1,554
1989	85	109	81	64	136	104	54	60	113	131	169	44	1,150
1990	103	108	55	195	177	66	50	70	85	215	146	204	1,474
1991	107	53	150	85	132	18	64	131	180	137	168	86	1,311
1992	141	162	111	40	54	34	64	64	79	79	108	136	1,072
1993	91	166	153	85	73	98	129	45	79	226	134	262	1,541
1994	130	57	263	145	146	106	22	62	83	34	195	155	1,398
1995	133	114	53	77	77	151	182	65	71	127	214	149	1,413
1996	109	210	63	135	115	40	181	20	309	85	73	170	1,510
1997	156	77	132	80	146	86	12	46	91	32	151	108	1,117
1998	205	130	117	86	73	142	78	67	129	161	133	67	1,388
1999	160	110	237	59	59	45	57	89	121	162	88	143	1,330
2000	205	58	117	110	88	65	99	67	102	166	114	198	1,389
2001	109	85	85	110	192	66	69	43	60	93	84	76	1,072
2002	155	139	140	148	84	80	52	61	106	0	266	124	1,355
2003	71	151	189	90	26	99	32	102	164	174	95	200	1,393
2004	32	109	60	126	88	54	82	128	69	113	234	155	1,250
2005	108	69	148	123	319	28	40	25	111	251	179	150	1,551
2006	109	92	37	123	99	243	126	68	37	178	118	129	1,359
2007	150	30	57	110	92	124	138	196	95	78	177	112	1,359
2008	151	198	176	60	134	69	80	299	118	85	149	214	1,733
2009	128	92	156	159	89	149	71	180	73	167	95	150	1,509
2010	92	72	93	40	48	100	125	65	118	154	226	191	1,324
2011	112	166	68	124	124	144	94	136	43	335	192	184	1,722
2012	121	107	65	91	102	75	59	54	296	104	53	155	1,282
2013	21	110	19	68	100	174	111	67	122	131	185	198	1,306
2014	241	132	165	143	32	112	79	1	72	107	211	278	1,573
2015	141	161	178	103	57	154	117	76	76	190	127	157	1,537
2016	149	147	145	160	100	73	73	45	85	219	131	184	1,511
2017	163	156	130	91	156	69	145	94	142	67	145	180	1,538
Minimum	21	30	19	30	26	18	8	1	18	0	37	44	1,050
Average	139	118	123	114	107	97	93	98	103	132	152	164	1,439
Maximum	313	210	263	228	319	307	190	387	309	335	268	295	1,933

\\KPL\VA-Prj\1\01\00708\04\VA\Report2 - Preliminary Design Report for EIS\Rev 1\Appendices\Appendix D - Water Balance Inputs, Assumptions and Results\Appendix D1 - Climate Data Time Series_r1.xlsx]Table D1.1 Precip

1	12JUN20	ISSUED WITH REPORT VA101-00708\04-2	HW	CKJ
REV	DATE	DESCRIPTION	PREP'D	RW'D

TABLE D1.2

**ATLANTIC MINING NS CORP.
FIFTEEN MILE STREAM PROJECT**

AVERAGE MONTHLY TEMPERATURE TIME SERIES

Print Jun/11/20 9:20:58

Year	Average Temperature (°C)											
	Jan	Feb	Mar	Apr	May	Jun	Jul	Aug	Sep	Oct	Nov	Dec
1961	-7.9	-7.0	-3.5	2.4	9.2	15.3	17.6	18.9	16.8	10.6	5.1	-1.3
1962	-5.7	-9.6	-0.8	4.0	8.9	14.2	15.3	17.2	13.3	8.6	3.3	-3.3
1963	-3.2	-7.3	-3.0	1.4	9.2	14.5	19.2	16.6	12.0	10.0	5.1	-7.2
1964	-5.3	-5.2	-2.1	2.9	10.0	13.2	17.2	16.2	12.8	8.5	1.7	-2.0
1965	-7.2	-6.6	-2.3	2.2	8.3	14.6	17.9	17.6	13.1	7.8	1.4	-3.5
1966	-4.0	-5.9	0.1	2.8	9.3	14.3	17.9	18.4	12.9	8.5	5.7	-0.5
1967	-4.3	-7.9	-5.0	0.7	6.9	15.5	19.8	18.8	14.2	9.4	3.3	-2.9
1968	-8.3	-8.0	-0.5	5.4	8.5	13.6	19.4	17.0	15.8	10.5	1.8	-1.8
1969	-4.0	-2.8	-1.4	3.7	8.2	16.1	17.4	18.7	14.5	7.7	5.2	0.0
1970	-9.5	-5.1	-1.6	3.0	9.9	14.6	18.8	18.5	13.1	9.8	4.0	-6.4
1971	-8.0	-5.3	-0.6	3.6	10.1	13.9	18.6	18.1	14.7	9.5	2.8	-4.6
1972	-5.9	-7.7	-3.3	1.3	9.5	15.0	18.3	17.2	14.3	6.7	1.0	-4.7
1973	-5.8	-6.3	-0.1	3.9	8.6	15.9	19.7	18.5	13.2	8.3	1.9	0.9
1974	-6.5	-6.7	-2.3	4.1	6.5	15.1	16.2	19.1	13.8	5.6	3.1	-1.6
1975	-5.2	-7.5	-2.5	2.5	9.3	14.7	19.6	17.8	14.3	8.3	4.9	-3.9
1976	-6.1	-3.8	-1.2	4.4	10.2	17.3	18.0	18.6	14.0	7.9	1.8	-4.2
1977	-7.6	-4.9	0.7	3.5	9.7	13.7	18.4	18.7	13.2	8.9	4.6	-2.5
1978	-5.1	-6.8	-2.8	2.2	10.4	14.4	18.0	19.4	11.8	7.5	1.1	-3.2
1979	-3.6	-8.4	0.3	3.9	11.0	15.5	18.8	17.3	13.8	8.7	5.6	-2.4
1980	-6.0	-6.7	-2.6	5.0	9.2	13.9	17.4	18.8	13.1	8.0	1.8	-6.0
1981	-8.1	-1.1	0.0	4.6	10.4	15.1	18.3	17.6	14.0	8.2	3.7	0.4
1982	-8.5	-6.3	-1.7	3.4	9.2	13.7	19.1	16.6	14.8	8.2	4.9	-0.7
1983	-3.7	-5.1	0.0	5.5	9.9	16.0	18.4	17.8	15.9	9.0	4.4	-2.5
1984	-5.7	-1.4	-2.2	4.0	9.8	14.7	20.1	20.6	13.3	8.4	3.7	-1.1
1985	-8.6	-5.1	-2.4	3.0	9.3	14.1	19.0	17.7	14.8	8.1	2.3	-5.1
1986	-3.8	-6.6	-2.0	6.1	9.5	13.2	16.7	17.1	12.2	7.2	1.0	-2.8
1987	-6.3	-7.4	-2.0	5.6	9.5	14.4	18.8	17.8	14.2	9.1	1.8	-3.4
1988	-5.2	-4.9	-1.4	3.4	10.8	13.4	19.1	19.3	12.5	7.4	4.0	-4.4
1989	-5.4	-6.9	-3.7	3.9	12.7	15.4	17.6	18.4	14.6	7.8	2.0	-9.6
1990	-2.9	-6.8	-2.2	4.2	8.3	16.0	19.7	19.9	13.9	10.5	3.5	-0.4
1991	-8.1	-4.3	0.1	4.2	10.4	15.3	19.6	19.2	13.7	10.1	4.9	-4.0
1992	-6.9	-6.2	-3.8	2.1	9.5	15.7	16.4	18.7	14.9	7.8	1.4	-3.0
1993	-7.4	-10.0	-2.4	4.4	10.0	14.0	17.6	18.5	14.6	6.6	2.9	-1.6
1994	-9.3	-7.7	-1.0	5.7	9.0	16.4	20.7	18.4	13.5	8.9	4.4	-2.2
1995	-3.2	-6.7	-1.6	3.1	8.7	15.9	19.3	17.8	13.0	11.2	2.9	-4.7
1996	-6.7	-4.2	-1.6	4.1	8.3	15.1	17.7	18.9	14.4	7.4	2.6	0.7
1997	-6.1	-5.1	-4.1	2.4	8.7	14.1	19.3	18.2	14.6	7.0	2.0	-2.8
1998	-4.1	-2.6	0.6	5.3	12.4	14.2	19.3	19.3	14.6	8.3	2.6	-1.2
1999	-4.5	-2.8	2.6	4.2	13.0	17.4	20.3	18.9	18.5	7.8	4.7	-0.5
2000	-4.6	-3.8	1.2	5.2	9.2	15.7	18.0	18.9	14.3	9.8	4.5	-3.2
2001	-6.3	-6.3	-1.2	3.2	11.4	16.6	18.0	20.2	15.9	10.7	4.2	-0.1
2002	-3.9	-4.4	-0.8	3.9	10.0	13.5	17.9	19.7	15.6	7.3	2.7	-2.9
2003	-7.9	-7.3	-2.2	2.8	9.3	15.7	20.3	18.9	17.0	10.1	4.5	-0.6
2004	-10.3	-5.3	-2.0	4.6	9.0	14.0	18.7	19.5	13.9	9.9	2.7	-2.0
2005	-8.5	-4.3	-1.6	5.0	8.4	15.5	19.0	19.5	16.2	10.9	5.0	-1.8
2006	-1.5	-5.1	0.0	5.3	11.9	16.4	20.0	17.4	14.8	9.3	6.0	-0.7
2007	-4.5	-7.9	-1.5	3.2	9.1	14.8	19.0	18.6	15.2	10.3	2.9	-5.0
2008	-3.9	-3.8	-2.6	5.5	9.5	15.6	20.6	18.2	14.4	8.9	3.8	-1.4
2009	-7.7	-4.5	-1.7	5.4	10.8	15.6	17.6	19.9	13.7	6.9	5.6	-2.5
2010	-4.1	-3.2	2.1	7.3	11.1	15.2	19.8	19.4	16.3	9.2	4.1	0.7
2011	-4.6	-5.4	-0.9	4.9	10.6	13.7	18.8	18.5	16.0	10.3	5.2	0.5
2012	-3.7	-4.0	1.9	6.0	11.8	14.6	20.0	20.7	15.8	10.8	4.0	0.1
2013	-7.1	-4.6	-0.6	5.0	10.4	16.1	21.0	18.9	14.9	9.5	2.6	-4.2
2014	-4.4	-5.1	-4.1	4.3	9.3	15.4	20.2	18.4	14.8	11.3	3.7	0.5
2015	-6.8	-10.0	-4.7	2.0	11.4	13.3	18.6	20.7	17.2	8.6	4.6	1.5
2016	-4.3	-2.1	-1.0	3.6	10.7	14.4	19.5	19.6	16.1	10.2	4.8	-2.9
2017	-3.0	-3.4	-3.5	5.2	10.2	15.7	18.6	18.8	16.6	12.4	4.1	-2.6
Minimum	-10.3	-10.0	-5.0	0.7	6.5	13.2	15.3	16.2	11.8	5.6	1.0	-9.6
Average	-5.8	-5.6	-1.5	3.9	9.8	14.9	18.7	18.6	14.5	8.9	3.5	-2.4
Maximum	-1.5	-1.1	2.6	7.3	13.0	17.4	21.0	20.7	18.5	12.4	6.0	1.5

\\KPL\VA-P\j\110100708\04\VA\Report\2 - Preliminary Design Report for EIS\Rev 1\Appendices\Appendix D - Water Balance Inputs, Assumptions and Results\Appendix D1 - Climate Data Time Series_r1.xlsx\Table D1.2 Temp

1	12JUN20	ISSUED WITH REPORT VA101-00708\04-2	HW	CKJ
REV	DATE	DESCRIPTION	PREP'D	RW'D

TABLE D1.3

**ATLANTIC MINING NS CORP.
FIFTEEN MILE STREAM PROJECT**

TOTAL MONTHLY POTENTIAL EVAPOTRANSPIRATION TIME SERIES

Print Jun/11/20 9:20:58

Year	Potential Evapotranspiration (mm)												Total
	Jan	Feb	Mar	Apr	May	Jun	Jul	Aug	Sep	Oct	Nov	Dec	
1961	0	0	0	11	50	83	100	100	73	43	16	0	476
1962	0	0	0	22	54	81	91	94	61	38	13	0	453
1963	0	0	0	7	53	81	111	89	54	43	18	0	458
1964	0	0	0	16	60	76	102	89	59	38	7	0	447
1965	0	0	0	12	50	83	105	95	60	35	6	0	445
1966	0	0	1	14	54	80	104	98	58	36	20	0	464
1967	0	0	0	3	39	85	114	100	63	39	11	0	456
1968	0	0	0	26	48	75	112	90	70	43	6	0	470
1969	0	0	0	18	47	89	100	100	64	32	18	0	468
1970	0	0	0	15	56	80	108	98	58	41	14	0	470
1971	0	0	0	18	57	77	107	96	65	40	10	0	469
1972	0	0	0	7	56	84	107	93	65	29	4	0	446
1973	0	0	0	19	49	87	113	98	59	35	7	3	470
1974	0	0	0	22	40	85	96	103	63	25	12	0	446
1975	0	0	0	12	53	81	113	95	63	35	17	0	468
1976	0	0	0	21	57	95	103	99	62	32	6	0	475
1977	0	0	3	17	55	76	106	100	59	37	16	0	471
1978	0	0	0	12	61	81	105	104	54	33	4	0	453
1979	0	0	1	19	62	85	108	92	61	36	19	0	480
1980	0	0	0	26	54	78	101	101	59	35	7	0	460
1981	0	0	0	23	59	83	106	94	62	34	13	1	475
1982	0	0	0	17	53	76	111	89	66	35	17	0	464
1983	0	0	0	26	54	87	105	94	69	36	14	0	485
1984	0	0	0	19	54	80	115	109	58	34	12	0	480
1985	0	0	0	15	54	78	110	95	66	34	8	0	461
1986	0	0	0	32	57	76	99	93	57	33	4	0	452
1987	0	0	0	27	54	79	108	95	63	38	6	0	471
1988	0	0	0	17	62	74	110	103	56	31	14	0	467
1989	0	0	0	19	71	84	101	98	64	32	7	0	476
1990	0	0	0	19	45	86	112	105	60	42	11	0	482
1991	0	0	0	19	57	82	112	101	59	41	16	0	487
1992	0	0	0	11	55	87	96	100	67	33	5	0	454
1993	0	0	0	22	58	78	102	99	66	28	10	0	464
1994	0	0	0	26	49	89	118	97	59	36	14	0	487
1995	0	0	0	15	49	87	111	95	57	46	10	0	470
1996	0	0	0	21	48	84	103	101	65	32	9	3	464
1997	0	0	0	12	51	79	112	98	66	30	7	0	454
1998	0	0	2	24	68	77	110	102	64	33	8	0	489
1999	0	0	9	17	68	91	114	97	79	29	13	0	517
2000	0	0	5	24	51	85	103	100	63	40	15	0	485
2001	0	0	0	14	61	89	101	106	68	42	13	0	493
2002	0	0	0	19	57	74	103	105	69	31	9	0	467
2003	0	0	0	12	50	84	115	99	73	40	14	0	487
2004	0	0	0	22	51	77	107	103	61	41	9	0	472
2005	0	0	0	22	45	83	108	102	70	43	16	0	489
2006	0	0	0	24	64	88	113	90	64	36	19	0	498
2007	0	0	0	15	51	81	109	98	67	42	10	0	473
2008	0	0	0	25	52	84	118	96	63	36	12	0	486
2009	0	0	0	25	60	85	101	105	60	28	18	0	483
2010	0	0	8	32	59	80	112	101	70	35	12	2	511
2011	0	0	0	22	58	74	107	97	70	41	17	1	487
2012	0	0	7	26	62	76	112	108	67	42	12	0	512
2013	0	0	0	22	56	86	119	99	64	37	8	0	492
2014	0	0	0	19	50	83	115	96	64	45	12	1	487
2015	0	0	0	9	62	71	105	109	75	34	14	4	484
2016	0	0	0	16	58	77	111	103	70	40	15	0	489
2017	0	0	0	23	54	83	105	98	71	49	12	0	496
Minimum	0	0	0	3	39	71	91	89	54	25	4	0	445
Average	0	0	1	19	55	82	107	98	64	37	12	0	474
Maximum	0	0	9	32	71	95	119	109	79	49	20	4	517

\\KPL\VA-Prj\110100708\04\VA\Report\2 - Preliminary Design Report for EIS\Rev 1\Appendices\Appendix D - Water Balance Inputs, Assumptions and Results\Appendix D1 - Climate Data Time Series_r1.xlsx|Table D1.3 PET

1	12/JUN/20	ISSUED WITH REPORT VA101-00708/04-2	HW	CKJ
REV	DATE	DESCRIPTION	PREP'D	RW'D

APPENDIX D2

Water Balance Inputs

(Table D2.1)

TABLE D2.1
ATLANTIC MINING NS CORP.
FIFTEEN MILE STREAM PROJECT
WATER BALANCE INPUTS AND ASSUMPTIONS

Model Input	Description	Value	Units	Source	
TMF	Seepage losses from the TMF	10	L/s	Assumption by KP	
	Recovery rate of the seepage	90	%	Assumption by KP	
	Consolidation of the tailings within the TMF	0		Assumption by KP	
Mill Process / Tailings Production	Tailings specific gravity	2.79	-	Assumption by KP	
	Tailings dry density	1.30	t/m ³		
	Tailings production rate	5,500	tpd	As discussed in Section 4.2 Design Basis of Report	
	Tailings solids content	0.38	-	By weight.	
	Fraction of fresh water in slurry	5.8	%		
Open Pit	Fraction of water in the ore	2.5	%	Assumption by KP ²	
	Groundwater inflow into Egerton-MacLean Open Pit	500	m ³ /day	Assumption by KP ²	
Catchment Areas ¹	Undisturbed area of East Seepage Collection Pond	71,900	m ²	Used for undisturbed runoff.	
	Undisturbed area of North Seepage Collection Pond	71,900	m ²		
	Total catchment area of Non-PAG Waste Rock Stockpile	378,000	m ²		
	Total catchment area of Egerton-MacLean Open Pit	495,600	m ²		
	Total catchment area of Ore Stockpile	171,900	m ²		
	Total catchment area of PAG Waste Rock Stockpile	390,000	m ²	Includes the disturbed and undisturbed area which are used for runoff.	
	Total catchment area of Plant Site Pond	293,600	m ²		
	Total catchment area of Till Stockpile	227,200	m ²		
	Total catchment area of TMF	1,475,200	m ²		
	Disturbed area of Non-PAG Waste Rock Stockpile	166,000 to 307,000	m ²		
	Disturbed area of Egerton-MacLean Open Pit	272,200	m ²	Used for disturbed runoff.	
	Disturbed area of Ore Stockpile	93,000 to 150,000	m ²		
	Disturbed area of PAG Waste Rock Stockpile	45,000 to 244,000	m ²		
	Disturbed area of Plant Site; Mine Infrastructure	65,000; 13,300	m ²		
	Disturbed area of Till Stockpile	99,000 to 133,000	m ²		
Disturbed area of TMF beach	0 to 431,000	m ²	Used for beach runoff.		
Disturbed area of TMF embankment	127,300 to 303,000	m ²			
Disturbed area of TMF pond	507,900 to 791,700	m ²			
Pond Areas	Area of Plant Site Pond	7,500	m ²	Used for direct precipitation to the pond.	
	Area-capacity curve of Ore Stockpile Collection Pond	(table)	m ²		
	Area-capacity curve of Till Stockpile Collection Pond	(table)	m ²	Used for direct precipitation and evaporation of the pond.	
	Area-capacity curve of Non-PAG Waste Rock Stockpile Collection Pond	(table)	m ²		
	Area of East Seepage Collection Pond	4,000	m ²		
	Area of North Seepage Collection Pond	7,800	m ²	General arrangement, stage 4 (Year 7)	
Volumes	Minimum volume of the TMF	270,000	m ³	One month reclaim requirements.	
	Maximum volume of the TMF	800,000	m ³	Three months reclaim requirements.	
	Maximum volume of Egerton-MacLean Open Pit	13,490,000	m ³		
	Maximum volume of the East Seepage Collection Pond	15,000	m ³		
	Maximum volume of the North Seepage Collection Pond	20,000	m ³		
	Maximum volume of the Ore Stockpile Collection Pond	23,000	m ³		
	Maximum volume of the Till Stockpile Collection Pond	22,000	m ³	Based on KP's pond design	
Hydrometeorological Parameters	Maximum volume of the Non-PAG Waste Rock Stockpile Collection Pond	35,000	m ³		
	Potential evapotranspiration time series		mm	Calculated using the Thornthwaite equation (Thornthwaite, 1948)	
	Precipitation time series	(time series) ³	mm	From "Halifax Stanfield International Airport" climate station on Environment Canada	
	Temperature time series		°C		
	Sublimation rate	Potential sublimation in the month.	0	mm/day	Hydrometeorology Report (KP, 2018b)
	Maximum temperature for snow	The maximum temperature at which precipitation falls as snow.	2	°C	Assumption by KP; typical values range from -1 to 3 °C
	Minimum temperature for rain	The minimum temperature at which precipitation falls as rain.	-2	°C	Assumption by KP; typical values range from -3 to 1 °C
	Snow base temperature	Base temperature above which snowmelt is allowed.	1	°C	Assumption by KP; typical values range from -1 to 1 °C
	Snowmelt factor	Melt rate coefficient.	100	mm/°C	Assumption by KP; typical values range from 50 to 120 mm/°C
Runoff Coefficients	Natural ground (undisturbed, reclaimed)	0.7	-	Assumption by KP ²	
	Disturbed ground	0.85	-		
	Dry Tailings	0.5	-		
	Embankment	0.9	-		
	Open Pit	0.9	-		
	Pond	1.0	-		

\\KPLVA-Prj\$1\01\00708\04\A\Report2 - Preliminary Design Report for EIS\Rev 1\Appendices\Appendix D - Water Balance Inputs, Assumptions and Results\Appendix D2 - Water Balance Inputs_r1.xlsx\Table D2.1

NOTES:

1. UNCAPTURED UNDISTURBED CATCHMENT AREAS ARE NOT SHOWN BECAUSE A DITCH DIVERSION EFFICIENCY OF 100% IS ASSUMED BY KP.
2. ASSUMPTIONS ARE BASED ON VALUES FROM TOUQUOY WATER BALANCE MODEL (STANTEC, 2016).
3. TIME SERIES HYDROMETEOROLOGICAL PARAMETERS ARE PRESENTED IN APPENDIX D1.

REV	DATE	ISSUED WITH REPORT	DESCRIPTION	HW	CKJ
0	07SEP19	ISSUED WITH REPORT VA101-00708/04-2		PREP'D	RW/D

APPENDIX D3

Operational Water Balance Results

(Tables D3.1 to D3.2)

TABLE D3.1

ATLANTIC MINING NS CORP.
FIFTEEN MILE STREAM PROJECT

ANNUAL WATER BALANCE RESULTS - MEAN (YEARS -1 to 7)

6/11/2020 9:47

Description	Annual Volume (m ³ /year)							
	Year -1	Year 1	Year 2	Year 3	Year 4	Year 5	Year 6	Year 7
Till Pond								
<i>Inflows</i>								
Precipitation	5,508	6,191	6,177	6,179	6,154	6,144	6,178	6,155
Runoff from PAG Waste Rock Stockpile (A9b)	273,330	311,618	322,525	333,190	337,074	336,517	338,364	337,149
Runoff from Till Stockpile	218,317	255,483	258,579	258,667	257,624	257,198	258,610	257,682
<i>Outflows</i>								
Dewater to TMF	473,332	571,267	585,255	596,010	598,827	597,832	601,125	598,960
Evaporation	2,024	2,026	2,026	2,025	2,025	2,027	2,026	2,027
<i>Balance</i>								
Total Inflows	497,155	573,292	587,281	598,036	600,853	599,859	603,151	600,986
Total Outflows	475,357	573,292	587,281	598,036	600,853	599,859	603,151	600,986
Change in Till Pond volume	21,798	0	0	0	0	0	0	0
Balance	0	0	0	0	0	0	0	0
PAG Waste Rock Stockpile								
<i>Inflows</i>								
Contact runoff (A9a)	11,039	35,495	53,651	66,554	72,666	72,545	72,944	72,682
Contact runoff (A9b)	16,599	71,607	137,207	197,071	225,897	225,523	226,761	225,947
Undisturbed runoff (A9a)	77,757	66,797	51,629	41,036	35,617	35,558	35,753	35,625
Undisturbed runoff (A9b)	256,731	240,012	185,318	136,119	111,178	110,994	111,603	111,202
<i>Outflows</i>								
Runoff to NAG Waste Rock Pond (A9a)	88,796	102,292	105,281	107,590	108,282	108,103	108,696	108,306
Runoff to Till Pond (A9b)	273,330	311,618	322,525	333,190	337,074	336,517	338,364	337,149
<i>Balance</i>								
Total Inflows	362,126	413,910	427,805	440,780	445,356	444,620	447,060	445,456
Total Outflows	362,126	413,910	427,805	440,780	445,356	444,620	447,060	445,456
Balance	0	0	0	0	0	0	0	0
NAG Waste Rock Stockpile								
<i>Inflows</i>								
Contact runoff	95,581	291,484	377,043	377,170	375,650	375,029	377,087	375,734
Undisturbed runoff	267,822	143,118	71,800	71,824	71,534	71,416	71,808	71,550
<i>Outflows</i>								
Runoff to NAG Waste Rock Pond	363,402	434,602	448,842	448,994	447,184	446,445	448,895	447,284
<i>Balance</i>								
Total Inflows	363,402	434,602	448,842	448,994	447,184	446,445	448,895	447,284
Total Outflows	363,402	434,602	448,842	448,994	447,184	446,445	448,895	447,284
Balance	0	0	0	0	0	0	0	0
NAG Waste Rock Pond								
<i>Inflows</i>								
Precipitation	8,443	9,630	9,608	9,612	9,573	9,557	9,610	9,575
Runoff from NAG Waste Rock Stockpile	363,402	434,602	448,842	448,994	447,184	446,445	448,895	447,284
Runoff from PAG Waste Rock Stockpile (A9a)	88,796	102,292	105,281	107,590	108,282	108,103	108,696	108,306
<i>Outflows</i>								
Dewater to TMF	422,190	543,373	560,580	563,045	561,889	560,952	564,050	562,012
Evaporation	3,144	3,151	3,152	3,150	3,150	3,152	3,151	3,153
<i>Balance</i>								
Total Inflows	460,642	546,524	563,731	566,195	565,040	564,105	567,201	565,165
Total Outflows	425,335	546,524	563,731	566,195	565,040	564,105	567,201	565,165
Change in NAG Waste Rock Pond volume	35,307	0	0	0	0	0	0	0
Balance	0	0	0	0	0	0	0	0

\\KPL\VA-Prj\10100708\04\A\Report\2 - Preliminary Design Report for EIS\Rev 1\Appendices\Appendix D - Water Balance Inputs, Assumptions and Results\Appendix D3 - Water Balance Results Operations_r0.xlsx\Table D3.1

REV	DATE	DESCRIPTION	PREP'D	RVW'D
1	12 JUN 20	ISSUED WITH REPORT VA101-00708-04-2	HW	GCH

TABLE D3.2

**ATLANTIC MINING NS CORP.
FIFTEEN MILE STREAM PROJECT**

MONTHLY WATER BALANCE RESULTS - MEAN (YEAR 7)

Print Jun/11/2019 9:47:06

Description	Monthly Volume (m ³ /mon)												SUM
	Jan	Feb	Mar	Apr	May	Jun	Jul	Aug	Sep	Oct	Nov	Dec	
Till Stockpile													
<i>Inflows</i>													
Contact runoff	30	70	3,917	44,044	35,275	11,027	10,424	10,992	11,682	14,776	17,135	3,406	162,777
Undisturbed runoff	17	41	2,284	20,567	6,429	6,078	6,408	6,811	8,615	9,990	1,986		94,905
<i>Outflows</i>													
Runoff to Till Pond	47	110	6,201	69,723	55,842	17,457	16,502	17,400	18,493	23,391	27,125	5,391	257,682
<i>Balance</i>													
Total Inflows	47	110	6,201	69,723	55,842	17,457	16,502	17,400	18,493	23,391	27,125	5,391	257,682
Total Outflows	47	110	6,201	69,723	55,842	17,457	16,502	17,400	18,493	23,391	27,125	5,391	257,682
Balance	0	0	0	0	0	0	0	0	0	0	0	0	0
Till Pond													
<i>Inflows</i>													
Precipitation	1	3	148	1,666	1,334	417	394	416	442	559	648	129	6,155
Runoff from PAG Waste Rock Stockpile (A9b)	62	144	8,113	91,225	73,063	22,840	21,591	22,766	24,196	30,604	35,490	7,054	337,149
Runoff from Till Stockpile	47	110	6,201	69,723	55,842	17,457	16,502	17,400	18,493	23,391	27,125	5,391	257,682
<i>Outflows</i>													
Dewater to TMF	110	257	14,459	162,532	130,005	40,365	38,028	40,162	42,857	54,400	63,212	12,572	598,960
Evaporation	0	0	3	82	234	349	460	420	273	156	49	1	2,027
<i>Balance</i>													
Total Inflows	110	257	14,462	162,614	130,239	40,714	38,488	40,582	43,130	54,554	63,263	12,574	600,986
Total Outflows	110	257	14,462	162,614	130,239	40,714	38,488	40,582	43,130	54,556	63,261	12,574	600,986
Change in Till Pond volume	0	0	0	0	0	0	0	0	0	-2	2	0	0
Balance	0	0	0	0	0	0	0	0	0	0	0	0	0
PAG Waste Rock Stockpile													
<i>Inflows</i>													
Contact runoff (A9a)	13	31	1,749	19,666	15,751	4,924	4,655	4,908	5,216	6,598	7,851	1,521	72,682
Contact runoff (A9b)	41	97	5,437	61,136	48,965	15,307	14,470	15,257	16,215	20,510	23,785	4,727	225,947
Undisturbed runoff (A9a)	7	15	857	9,639	7,720	2,413	2,281	2,406	2,557	3,234	3,750	745	35,625
Undisturbed runoff (A9b)	20	48	2,676	30,089	24,099	7,533	7,122	7,509	7,981	10,094	11,706	2,327	111,202
<i>Outflows</i>													
Runoff to NAG Waste Rock Pond (A9a)	20	46	2,606	29,305	23,471	7,337	6,936	7,313	7,773	9,831	11,401	2,266	108,306
Runoff to Till Pond (A9b)	62	144	8,113	91,225	73,063	22,840	21,591	22,766	24,196	30,604	35,490	7,054	337,149
<i>Balance</i>													
Total Inflows	82	190	10,719	120,531	96,534	30,177	28,527	30,080	31,968	40,436	46,891	9,320	445,456
Total Outflows	82	190	10,719	120,531	96,534	30,177	28,527	30,080	31,968	40,436	46,891	9,320	445,456
Balance	0	0	0	0	0	0	0	0	0	0	0	0	0
NAG Waste Rock Stockpile													
<i>Inflows</i>													
Contact runoff	69	161	9,042	101,665	81,425	25,454	24,062	25,372	26,965	34,107	39,552	7,861	375,734
Undisturbed runoff	13	31	1,722	19,360	15,506	4,847	4,582	4,831	5,135	6,495	7,532	1,497	71,550
<i>Outflows</i>													
Runoff to NAG Waste Rock Pond	82	191	10,763	121,025	96,930	30,301	28,644	30,203	32,100	40,601	47,084	9,358	447,284
<i>Balance</i>													
Total Inflows	82	191	10,763	121,025	96,930	30,301	28,644	30,203	32,100	40,601	47,084	9,358	447,284
Total Outflows	82	191	10,763	121,025	96,930	30,301	28,644	30,203	32,100	40,601	47,084	9,358	447,284
Balance	0	0	0	0	0	0	0	0	0	0	0	0	0
NAG Waste Rock Pond													
<i>Inflows</i>													
Precipitation	2	4	230	2,591	2,075	649	613	647	687	869	1,008	200	9,575
Runoff from NAG Waste Rock Stockpile	82	191	10,763	121,025	96,930	30,301	28,644	30,203	32,100	40,601	47,084	9,358	447,284
Runoff from PAG Waste Rock Stockpile (A9a)	20	46	2,606	29,305	23,471	7,337	6,936	7,313	7,773	9,831	11,401	2,266	108,306
<i>Outflows</i>													
Dewater to TMF	104	241	13,596	152,795	122,113	37,745	35,478	37,514	40,131	51,062	59,413	11,822	562,012
Evaporation	0	0	4	127	364	542	716	654	425	243	76	2	3,153
<i>Balance</i>													
Total Inflows	104	241	13,600	152,921	122,476	38,287	36,194	38,163	40,560	51,302	59,493	11,824	565,165
Total Outflows	104	241	13,600	152,921	122,476	38,287	36,194	38,168	40,555	51,306	59,489	11,824	565,165
Change in NAG Waste Rock Pond volume	0	0	0	0	0	0	0	-4	4	-4	4	0	0
Balance	0	0	0	0	0	0	0	0	0	0	0	0	0

APPENDIX D4

Closure Water Balance Results

(Tables D4.1 to D4.2)

TABLE D4.1

ATLANTIC MINING NS CORP.
FIFTEEN MILE STREAM PROJECT

ANNUAL WATER BALANCE RESULTS - MEAN (CLOSURE AND POST-CLOSURE)

6/11/2020 9:52

Description	Annual Volume (m ³ /year)						
	Year 8	Year 9	Year 10	Year 11	Year 12	Year 13	Year 14
TMF							
<i>Inflows</i>							
Catchment runoff - Undisturbed	255,167	254,182	256,179	255,973	255,787	254,621	254,382
Dewater from East Seepage Collection Pond	193,895	192,240	193,331	193,113	193,353	192,461	192,263
Dewater from NAG Waste Rock Pond	35,307	0	0	0	0	0	0
Dewater from North Seepage Collection Pond	228,245	226,422	227,796	227,552	227,783	226,707	226,474
Dewater from Ore and Open Pit Pond	23,126	0	0	0	0	0	0
Dewater from Till Pond	21,798	0	0	0	0	0	0
Embankment runoff	153,202	152,610	153,809	153,686	153,574	152,874	152,730
Reclaimed beach runoff	1,236,426	1,231,652	1,241,327	1,240,331	1,239,431	1,233,778	1,232,619
Water in tailings from Plant Site	6,500	0	0	0	0	0	0
<i>Outflows</i>							
Collected seepage to East Seepage Collection Pond	55,631	54,907	54,905	54,791	55,062	54,889	54,817
Collected seepage to North Seepage Collection Pond	55,631	54,907	54,905	54,791	55,062	54,889	54,817
Dewater to Egerton-MacLean Open Pit	2,817,488	1,934,838	1,950,181	1,948,646	1,947,321	1,938,216	1,936,399
Seepage losses	12,719	12,455	12,451	12,426	12,483	12,448	12,435
<i>Balance</i>							
Total Inflows	2,153,666	2,057,107	2,072,441	2,070,654	2,069,929	2,060,440	2,058,468
Total Outflows	2,941,469	2,057,107	2,072,441	2,070,654	2,069,929	2,060,440	2,058,468
Change in TMF pond volume	-787,803	0	0	0	0	0	0
Balance	0	0	0	0	0	0	0
East Seepage Collection Pond							
<i>Inflows</i>							
Collected seepage from TMF	55,631	54,907	54,905	54,791	55,062	54,889	54,817
Embankment runoff	61,281	61,044	61,524	61,474	61,430	61,150	61,092
Precipitation	5,778	5,756	5,801	5,796	5,792	5,765	5,760
Undisturbed runoff	72,732	72,451	73,020	72,962	72,909	72,576	72,508
<i>Outflows</i>							
Dewater to TMF	193,525	192,261	193,353	193,128	193,296	192,485	192,281
Evaporation	1,896	1,897	1,897	1,895	1,897	1,895	1,896
<i>Balance</i>							
Total Inflows	195,421	194,157	195,249	195,023	195,193	194,380	194,177
Total Outflows	195,421	194,157	195,249	195,023	195,193	194,380	194,177
Change in East Seepage Collection Pond volume	0	0	0	0	0	0	0
Balance	0	0	0	0	0	0	0
North Seepage Collection Pond							
<i>Inflows</i>							
Collected seepage from TMF	55,631	54,907	54,905	54,791	55,062	54,889	54,817
Embankment runoff	91,921	91,566	92,285	92,211	92,145	91,724	91,638
Precipitation	11,267	11,223	11,311	11,302	11,294	11,243	11,232
Undisturbed runoff	72,732	72,451	73,020	72,962	72,909	72,576	72,508
<i>Outflows</i>							
Dewater to TMF	227,852	226,449	227,823	227,571	227,711	226,736	226,497
Evaporation	3,698	3,698	3,698	3,695	3,698	3,695	3,698
<i>Balance</i>							
Total Inflows	231,551	230,147	231,522	231,266	231,410	230,432	230,195
Total Outflows	231,551	230,147	231,522	231,266	231,410	230,432	230,195
Change in North Seepage Collection Pond volume	0	0	0	0	0	0	0
Balance	0	0	0	0	0	0	0
Plant Site							
<i>Inflows</i>							
Catchment runoff - Undisturbed	296,838	295,693	298,015	297,776	297,560	296,203	295,925
<i>Outflows</i>							
Catchment runoff to Environment	296,838	295,693	298,015	297,776	297,560	296,203	295,925
<i>Balance</i>							
Total Inflows	296,838	295,693	298,015	297,776	297,560	296,203	295,925
Total Outflows	296,838	295,693	298,015	297,776	297,560	296,203	295,925
Balance	0	0	0	0	0	0	0

TABLE D4.1

**ATLANTIC MINING NS CORP.
FIFTEEN MILE STREAM PROJECT**

ANNUAL WATER BALANCE RESULTS - MEAN (CLOSURE AND POST-CLOSURE)

6/11/2020 9:52

Description	Annual Volume (m ³ /year)						
	Year 8	Year 9	Year 10	Year 11	Year 12	Year 13	Year 14
Egerton-MacLean Open Pit							
<i>Inflows</i>							
Runoff from TMF	2,816,901	1,934,565	1,949,926	1,948,470	1,948,007	1,937,951	1,936,154
Groundwater inflow	183,000	182,500	182,500	182,500	183,000	182,500	182,500
Pitwall runoff	257,834	184,664	124,152	102,088	99,855	98,695	98,423
Precipitation	106,680	186,462	256,774	280,973	283,168	282,660	282,593
Runoff from NAG Waste Rock Stockpile	382,192	380,717	383,707	383,399	383,121	381,374	381,016
Runoff from PAG Waste Rock Stockpile (A9a)	95,784	95,415	96,164	96,087	96,017	95,579	95,490
Runoff from PAG Waste Rock Stockpile (A9b)	298,224	297,072	299,406	299,166	298,949	297,585	297,306
Runoff from Till Stockpile	229,686	228,799	230,596	230,411	230,244	229,194	228,979
Undisturbed runoff	225,859	224,987	226,754	226,572	226,408	225,375	225,164
<i>Outflows</i>							
Evaporation	38,584	64,467	86,142	93,442	94,343	94,560	94,764
Surplus to Water Treatment Plant	0	0	1,213,453	2,742,084	3,565,369	3,607,726	3,624,105
<i>Balance</i>							
Total Inflows	4,596,160	3,715,181	3,749,979	3,749,666	3,748,770	3,730,913	3,727,623
Total Outflows	38,584	64,467	1,299,595	2,835,526	3,659,711	3,702,287	3,718,869
Change in Egerton-MacLean Open Pit volume	4,557,577	3,650,714	2,450,385	914,140	89,059	28,627	8,753
Balance	0	0	0	0	0	0	0
Ore Stockpile							
<i>Inflows</i>							
Undisturbed runoff	173,834	173,163	174,523	174,383	174,256	173,462	173,299
<i>Outflows</i>							
Runoff to Environment	173,834	173,163	174,523	174,383	174,256	173,462	173,299
<i>Balance</i>							
Total Inflows	173,834	173,163	174,523	174,383	174,256	173,462	173,299
Total Outflows	173,834	173,163	174,523	174,383	174,256	173,462	173,299
Balance	0	0	0	0	0	0	0
Till Stockpile							
<i>Inflows</i>							
Contact runoff	134,479	133,960	135,012	134,904	134,806	134,191	134,065
Undisturbed runoff	95,207	94,839	95,584	95,508	95,438	95,003	94,914
<i>Outflows</i>							
Runoff to Egerton-MacLean Open Pit	229,686	228,799	230,596	230,411	230,244	229,194	228,979
<i>Balance</i>							
Total Inflows	229,686	228,799	230,596	230,411	230,244	229,194	228,979
Total Outflows	229,686	228,799	230,596	230,411	230,244	229,194	228,979
Balance	0	0	0	0	0	0	0
PAG Waste Rock Stockpile							
<i>Inflows</i>							
Contact runoff (A9a)	60,046	59,815	60,284	60,236	60,192	59,918	59,862
Contact runoff (A9b)	186,667	185,946	187,407	187,256	187,121	186,267	186,092
Undisturbed runoff (A9a)	35,738	35,600	35,880	35,851	35,825	35,662	35,628
Undisturbed runoff (A9b)	111,557	111,126	111,999	111,909	111,828	111,318	111,213
<i>Outflows</i>							
Runoff to Egerton-MacLean Open Pit (A9a)	95,784	95,415	96,164	96,087	96,017	95,579	95,490
Runoff to Egerton-MacLean Open Pit (A9b)	298,224	297,072	299,406	299,166	298,949	297,585	297,306
<i>Balance</i>							
Total Inflows	394,008	392,487	395,570	395,253	394,966	393,164	392,795
Total Outflows	394,008	392,487	395,570	395,253	394,966	393,164	392,795
Balance	0	0	0	0	0	0	0
NAG Waste Rock Stockpile							
<i>Inflows</i>							
Contact runoff	310,414	309,215	311,644	311,394	311,168	309,749	309,458
Undisturbed runoff	71,778	71,501	72,063	72,005	71,953	71,625	71,557
<i>Outflows</i>							
Runoff to Egerton-MacLean Open Pit	382,192	380,717	383,707	383,399	383,121	381,374	381,016
<i>Balance</i>							
Total Inflows	382,192	380,717	383,707	383,399	383,121	381,374	381,016
Total Outflows	382,192	380,717	383,707	383,399	383,121	381,374	381,016
Balance	0	0	0	0	0	0	0

NOTES:

1. ALL RUNOFF COEFFICIENTS ARE 0.7 FOR CLOSURE PERIOD (EXCEPT OPEN PIT, WHICH IS 0.90).

\\KPL\VA-Pri\S\1\01\00708\04\A\Report2 - Preliminary Design Report for EIS\Rev 1\Appendices\Appendix D - Water Balance Inputs, Assumptions and Results\Appendix D4 - Water Balance Results Closure_r1.xlsx\Table D4.1

REV	DATE	DESCRIPTION	PREP'D	CHK'D
1	12 JUN 20	ISSUED WITH REPORT VA101-00708/04-2	HW	CKJ

TABLE D4.2

**ATLANTIC MINING NS CORP.
FIFTEEN MILE STREAM PROJECT**

MONTHLY WATER BALANCE RESULTS - MEAN (YEAR 14)

Print Jun/11/20 9:52:24

Description	Monthly Volume (m ³ /mon)												
	Jan	Feb	Mar	Apr	May	Jun	Jul	Aug	Sep	Oct	Nov	Dec	SUM
PAG Waste Rock Stockpile													
<i>Inflows</i>													
Contact runoff (A9a)	11	35	1,541	16,131	12,954	4,025	3,874	4,043	4,320	5,469	6,218	1,238	59,861
Contact runoff (A9b)	36	110	4,791	50,148	40,271	12,513	12,044	12,568	13,430	17,002	19,331	3,848	186,092
Undisturbed runoff (A9a)	7	21	917	9,601	7,710	2,396	2,306	2,406	2,571	3,255	3,701	737	35,628
Undisturbed runoff (A9b)	21	66	2,863	29,970	24,067	7,478	7,198	7,511	8,026	10,161	11,553	2,300	111,213
<i>Outflows</i>													
Runoff to Egerton-MacLean Open Pit (A9a)	18	56	2,458	25,732	20,664	6,421	6,180	6,449	6,891	8,724	9,919	1,975	95,490
Runoff to Egerton-MacLean Open Pit (A9b)	57	176	7,654	80,118	64,338	19,991	19,242	20,078	21,456	27,163	30,884	6,148	297,306
<i>Balance</i>													
Total Inflows	75	232	10,113	105,850	85,003	26,412	25,422	26,527	28,347	35,888	40,803	8,123	392,795
Total Outflows	75	232	10,113	105,850	85,003	26,412	25,422	26,527	28,347	35,888	40,803	8,123	392,795
Balance	0	0	0	0	0	0	0	0	0	0	0	0	0
NAG Waste Rock Stockpile													
<i>Inflows</i>													
Contact runoff	59	183	7,967	83,393	66,968	20,808	20,029	20,899	22,333	28,274	32,146	6,400	309,458
Undisturbed runoff	14	42	1,842	19,283	15,485	4,812	4,631	4,833	5,164	6,538	7,433	1,480	71,557
<i>Outflows</i>													
Runoff to Egerton-MacLean Open Pit	73	225	9,809	102,676	82,454	25,619	24,660	25,732	27,497	34,811	39,579	7,879	381,016
<i>Balance</i>													
Total Inflows	73	225	9,809	102,676	82,454	25,619	24,660	25,732	27,497	34,811	39,579	7,879	381,016
Total Outflows	73	225	9,809	102,676	82,454	25,619	24,660	25,732	27,497	34,811	39,579	7,879	381,016
Balance	0	0	0	0	0	0	0	0	0	0	0	0	0

NOTES:

1. ALL RUNOFF COEFFICIENTS ARE 0.7 FOR CLOSURE PERIOD (EXCEPT OPEN PIT, WHICH IS 0.90).

\\KPLVA-Prij\1\01\00708\04\A\Report2 - Preliminary Design Report for EIS\Rev 1\Appendices\Appendix D - Water Balance Inputs, Assumptions and Results[Appendix D4 - Water Balance Results Closure_r1.xlsx]Table D4.2

1	12 JUN 20	ISSUED WITH REPORT VA101-20708/04-2	HW	CKJ
REV	DATE	DESCRIPTION	PREP'D	RW'D

APPENDIX E

Fifteen Mile Stream Terrain and Landform Mapping (KP, 2018)

(Pages E-1 to E-6)

March 5, 2018

File No.:VA101-00708/02-A.01
Cont. No.:VA17-01808

Mr. Alastair Tiver
VP Mine Development
Atlantic Gold Corporation
Suite 3083, Three Bentall Centre
595 Burrard Street
Vancouver, British Columbia
Canada, V7X 1L3

Dear Alastair,

Re: Fifteen Mile Stream Project – Desktop Terrain Analysis Study

1 – INTRODUCTION

This report details the findings of terrain analysis undertaken for the Fifteen Mile Stream Project. The Fifteen Mile Stream Project is a proposed open pit gold mine, which is being developed by Atlantic Gold Corporation (AGC) in eastern Halifax County, Nova Scotia. The property is located approximately 95 km northeast of the provincial capital of Halifax and 57 km northeast of the central milling facility at Touquoy. The proposed mine includes an Open Pit, a Tailings Management Facility (TMF), a Low Grade Ore (LGO) stockpile, a Waste Rock stockpile, Till and Topsoil Stockpiles, Truck Shop and Plant Site.

The terrain analysis comprised geomorphic interpretation of a Bare Earth Digital Elevation Model (DEM). Glacial landforms were mapped to facilitate a preliminary assessment of the surficial geology. The intent is that the glacial and post-glacial mapping provides a preliminary understanding of the site geologic model and can aid the planning of future geotechnical site investigations. The mapping may also help identify aggregate sources.

2 – METHODOLOGY

The mapping was completed using the *Global Mapper* software package. The Bare Earth Digital Elevation Model (DEM) was examined in 3D after applying the 'slope shader' function. The vertical scale was exaggerated to accentuate the landforms. The landforms were digitized within *Global Mapper* and then exported to the GIS program *ArcMap* in order to produce the final map.

3 – REFERENCE MATERIALS

Provincial (1:500,000 scale) surficial and bedrock geology maps, produced by the Province of Nova Scotia Department of Natural Resources, were referenced in the desktop study. The surficial geology map (Stea, 1992) details the distribution and nature of the Quaternary glacial deposits in Nova Scotia, as well as providing a summary of the major ice flow phases of the Wisconsinan glacial stage. The bedrock map (Keppie, 2000) shows that the geology for the project area comprises rocks of the Meguma Group, which are predominantly made up of metasedimentary schists and gneisses. Two local fault structures have been mapped through the project area (Horne, 2012). The Seigel Fault runs through the Open Pit in an E-W direction. A smaller structure, the Serpent Fault, intersects the pit along the eastern margin. To support future investigations, it would be useful to include any other mapped fault structures into the project area to see where they lie in relation to the facility footprints. Orthorectified imagery of the project area was obtained through the Geographic Information Services branch of the Nova Scotia Department of Internal Services. The orthophotos were utilized to confirm the presence of water and organic swamps within the study area.

4 – SITE DESCRIPTION

The site is located in eastern Halifax County, Nova Scotia, approximately 95km to the northeast of Halifax. The landscape is characterized by undulating to rolling topography, wetlands and woodlands dissected by a few lakes and streams. The Study Area is bound on the western margin by the Fifteen Mile Stream watercourse and Highway 374. The northern margin of the Study Area runs from Highway 374 across to the north end of Seloam Lake. The eastern margin of the Study Area extends to Moser Lake and Grassy Lake. The southern margin of the Study Area extends from Grassy Lake westwards to Highway 374.

The physiography, landforms and surficial deposits of the area are associated with the Late Wisconsinan Glaciation, which occurred between approximately 10,000 and 25,000 years before present. During this glacial period, four distinct ice flow phases are identified as having occurred in the region, with the early and late phase glacial periods contributing significantly to the glacial landforms and deposits currently identified in the project area.

5 – FINDINGS

5.1 GENERAL

The Landform Mapping is presented on Drawing 1. The following landforms were identified in the mapping:

- Glacial flutings
- Kame mounds
- Kettle holes
- Drumlins
- Glaciofluvial Outwash Plains, and
- Alluvial Floodplains.

Drumlins, and drumlinoid ridges, are typically smooth, oval-shaped or elliptical glacial landforms that are indicative of the presence of lodgement till. Drumlins were identified within the Study Area trending predominantly in a northwest to southeast direction. These landforms likely developed as the ice sheet advanced during the first phases of the Wisconsinan Glaciation.

Glacial flutings are low, linear ridges of lodgement till that formed beneath moving ice sheets during the last glaciation. Lodgement till is dense, or stiff, and contains significant interstitial silt that greatly lowers its permeability. The flutings are oriented predominantly in a west-southwest to east-northeast direction in the south part of the Study Area indicating that they were deposited during the Phase 4 ice flow of the Late Wisconsinan glaciation. The distribution of flutings suggests lodgement till is widespread across the southern part of the Study Area. Some flutings were also mapped in the northern section of the Study Area.

The generally hummocky nature of the topography indicates ablation till to be more widespread than lodgement till. Ice-contact glaciofluvial deposits occur as kames and kame complexes throughout the Study Area with the exception of the north, south and west margins. Kames were identified throughout the Study Area on the Bare Earth DEM along with some kettle holes. These features typically comprise laterally discontinuous mounds of gravel and sand with trace to some silt. They formed where streams deposited coarse sediment in cavities in the ice sheet. The kames commonly occur in groups, referred to as kame complexes. The kame deposits are interpreted to be relatively thin (in the order of several metres thick). Kettles are closed depressions that occur locally within the kame complexes. They formed when detached blocks of ice melted at the end of the last glaciation. Their floors are commonly below the water table, thus kettles are commonly occupied by ponds or lakes.

A broad outwash plain in the southwest part of the Study Area is evidence of glaciofluvial deposits from the receding ice sheet. A smaller outwash plain was identified in the northwestern part of the Study Area. The outwash plains are oriented in a north-northwest to south-southeast direction. The outwash plains are interpreted to comprise sands and gravels. Meltwater scarps were identified locally. These features were formed

by sub-glacial streams that eroded the ground on one bank but were bounded by ice on the other. Local sand and gravel deposits may accompany these features. Alluvial floodplains occur adjacent to the current watercourses.

The following sections describe the preliminary interpretation of conditions at the location of the proposed project facilities based on the landform mapping.

5.2 SITES OF PROPOSED FACILITIES

5.2.1 Open Pit Area

The surficial geology at the site of the proposed Open Pit has been historically mapped (Stea, 1992) as stony till plain. A small E-W oriented drumlin has been mapped adjacent to the open pit footprint (Drawing FM-401) at the western extent. Some kame mounds have also been identified in the area. The identification of a drumlinoid ridge in the vicinity would indicate that lodgement till comprise this landform. The identification of kame mounds would indicate that ice contact glaciofluvial deposits are also present in this area. It appears from the landform mapping that ablation till predominates in this area. There is an east-west oriented corridor of alluvial floodplain deposits and swamps across the footprint of the Open Pit. Surficial deposits of organic soils are expected to overlie the till deposits in this area. Future site investigations in this area will help to characterize the materials.

5.2.2 Tailings Management Facilities

Glaciofluvial landforms, including kame mounds and kettles, were mapped at the site of the proposed TSF area. Kame complexes occur across the footprint area of the proposed TSF, whereas the kettles occur locally. The presence of kames and kame complexes throughout this area indicate the presence of ice-contact glaciofluvial deposits. The hummocky nature of the topography suggests ablation till may also be present.

There are scattered organic swamps and wetland areas in topographic low areas. The east-west trend of the wetlands across the project site, along with a slightly decreasing gradient towards the west, may suggest a minor post-glacial drainage channel. It is interpreted that the swamps and wetlands comprise organic soils, possibly including peat. Alluvium may also be present.

5.2.3 Plant Site

It is interpreted that the surficial geology at the Plant Site predominantly comprises ablation till. Some localized kame mounds and kettles were identified near the Plant Site footprint, which suggests the presence of ice-contact glaciofluvial sands and gravels. The footprint of the plant site extends south into an area in which flutings were mapped. Flutings provide local evidence of lodgement till in this area. The flutings are oriented in a west-southwest and north-northeast direction suggesting that they were formed during the final phase (Phase 4) of the Late Wisconsinan glacial period.

5.2.4 Low Grade Ore Stockpile

The findings of the landform mapping of the proposed Low Grade Ore (LGO) Stockpile site indicate that the surficial geology predominantly comprises ablation till. The hummocky nature of the topography suggests ablation till may be present. Ice-contact glaciofluvial landforms comprising kame mounds and kettles were mapped across the site area.

5.2.5 Waste Rock Stockpile

The surficial soils at the Waste Rock Stockpile predominantly comprise ablation till. Kame mounds and kettles were mapped across the footprint area. The presence of ice-contact glaciofluvial sands and gravels is interpreted from the presence of kames and kettles.

5.2.6 Till Stockpile

A local drumlinoid ridge was mapped along the northeast margin of the till stockpile footprint. This landform suggests there is a local presence of lodgement till. The orientation of this landform is in a northwest to

southeast direction suggesting that this was formed during the latter stages of the Phase 1 ice flow of the early Wisconsin Glaciation. This drumlinoid feature is in close proximity to the tailings facility and should be investigated as a potential borrow source to support embankment construction.

5.2.7 Topsoil Stockpile

No obvious landforms were identified in the area of the topsoil stockpile. The hummocky topography of the area indicates that ablation till may be present.

6 – CONCLUSIONS AND DISCUSSION

Glacial landform mapping has been undertaken for the proposed Fifteen Mile Stream Project. The mapping was completed with the aid of a Bare Earth Digital Elevation Model. It is expected that the findings from this desktop study will be used to guide subsequent site investigations that will, in turn, 'field truth' the interpretation. The preliminary characterization provided in this desktop study will be updated following future site investigation programs.

There are extensive glacial landforms within the Study Area, and it is interpreted that the surficial geology predominantly comprises glacial till.

One limitation of this mapping method is that there is not always a clear morphological distinction between lodgement till and ablation till; however, it is interpreted that ablation till predominates the Study Area. Ablation till is expected to have a lower relative density and higher hydraulic conductivity than lodgement till. The local presence of drumlinoid ridges and flutings, particularly in the north, south and west parts of the Study Area indicate the presence of lodgement till in these areas. Kame and kettle topography is widespread and indicative of the presence of ice-contact glaciofluvial sands and gravels. These landforms were mapped at the sites of all the proposed facilities, particularly the TMF. Kames are expected to have slightly higher hydraulic conductivity than the ablation till, but the hydraulic conductivity would be expected to be significantly less than a 'clean', channelized, glaciofluvial sand and gravel deposit. The kames are likely to be relatively thin and underlain by ablation till.

Additional landforms identified include glaciofluvial outwash plains and alluvial floodplains. There is an east-west oriented corridor of alluvial floodplains and organic swamps in the area where the Open Pit is located. Widespread surficial deposits of organic soils are expected to have accumulated here. It is possible that glaciofluvial outwash deposits comprising sands and gravels underlie these deposits.

The landform mapping has highlighted several aspects of the geological model to be investigated further in future geotechnical site investigations. These include:

- Investigation of the extents of ablation till and lodgement till at the site and characterization of the geotechnical and hydrogeological properties of the two materials, in particular their strength and hydraulic conductivity. It is recommended that ablation till and lodgement till be distinguished on geological cross-sections following future site investigations.
- Field truthing and characterization of the geotechnical properties of the kame deposits.
- Confirmation of the interpreted thickness of the kames and the underlying materials, particularly those mapped within the TSF footprint, Waste Rock Stockpile, LGO Stockpile and Plant Site footprints.
- Investigation of the extents and nature of possible glaciofluvial deposits associated with the meltwater corridors that cross the proposed TSF embankment footprints.
- Investigation of the nature and depths of the organic soils.

Please do not hesitate to contact the undersigned, should you have any questions regarding this report.

Yours truly,
Knight Piésold Ltd.



Prepared:

Jesse Collison, P. Geo.
Project Scientist

Reviewed:

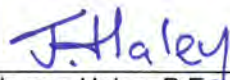

James Haley, P. Eng.
Specialist Geotechnical Engineer

Reviewed:



Daniel Fontaine, P. Eng.
Senior Civil Engineer | Associate

Approval that this document adheres to Knight Piésold Quality Systems: DDF

Attachments:

Drawing FM-401 Rev A Landform Map

References:

- Horne, R.J. & Dominy, S. (2012). Technical Report on Updated Mineral Resource Estimate – Acadian Mining Corporation, Fifteen Mile Stream Property, Halifax County, Nova Scotia, Canada. Available at: <http://www.liongoldcorp.com/wp-content/uploads/2013/12/Updated-Fifteen-Mile-Stream-Technical-Report-30-08-12.pdf>
- Keppie, J.D. (2000). Geological Map of the Province of Nova Scotia, [map]. 1:500,000. Map ME 2000-1. Halifax, NS: Nova Scotia Department of Natural Resources, Mines and Energy Branches.
- Stea, R.R., Conley, H., and Brown, Y. (1992). Surficial Geology of the Province of Nova Scotia, [map]. 1:500,000. Map 92-3. Halifax, NS: Nova Scotia Department of Natural Resources, Mines and Energy Branches.

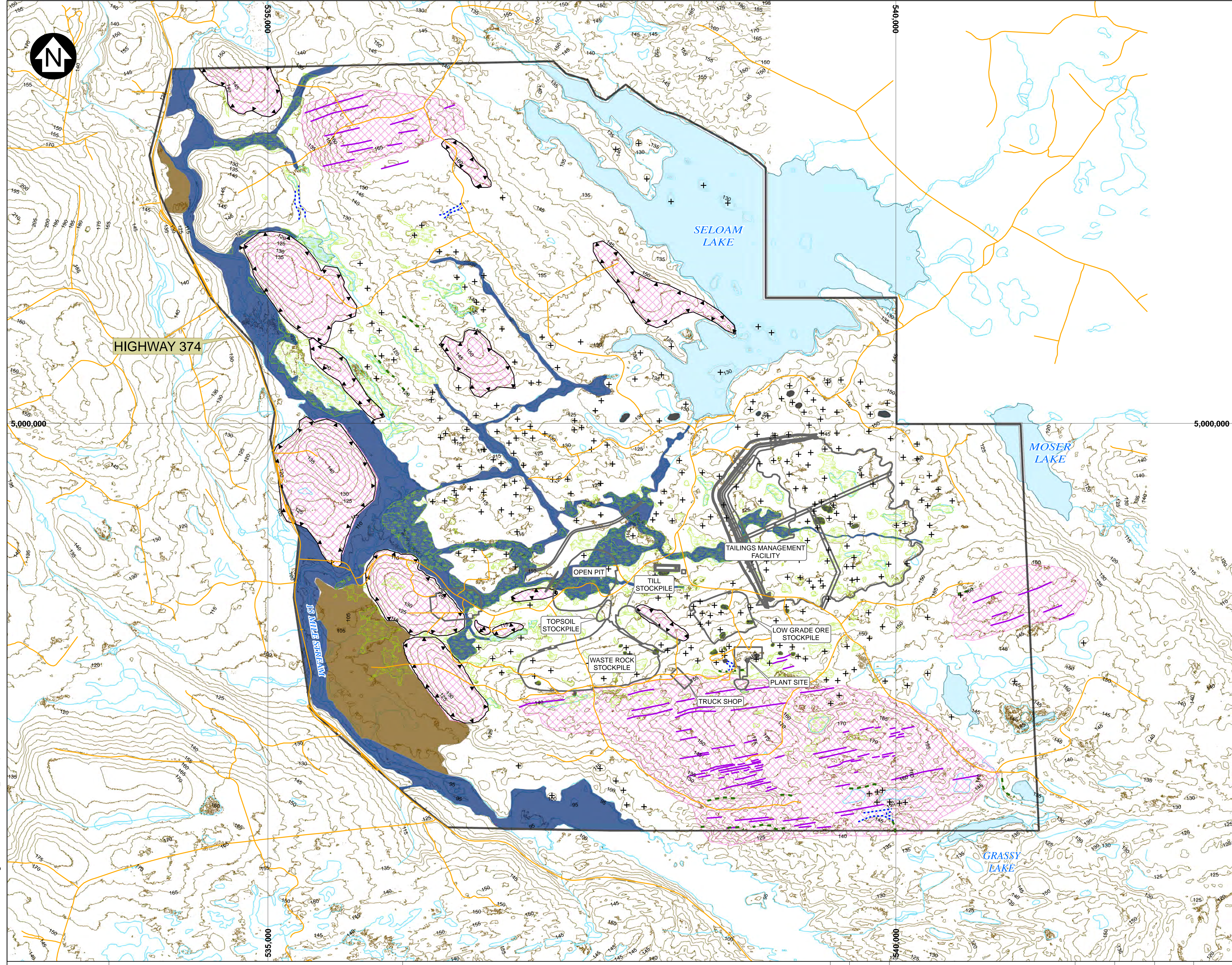

- LEGEND:**
- GENERAL**
- CONTOUR 5M
 - ROAD
 - RIVER/STREAM
 - LAKE
 - PROPOSED FACILITIES
 - STUDY AREA
- TERRAIN FEATURES**
- ORGANIC SWAMP
 - FLUVIAL FLOODPLAIN
 - GLACIOFLUVIAL OUTWASH PLAIN
 - MELTWATER SCARP
 - INCISED MELTWATER CHANNEL
 - KAME MOUND
 - KAME COMPLEX
 - KETTLE HOLE
 - HUMMOCKY TOPOGRAPHY - ABLATION TILL
 - FLUTING
 - DRUMLINOID RIDGE
 - LODGEMENT TILL

FOR INFORMATION ONLY

- NOTES:**
1. COORDINATE GRID IS IN METRES.
COORDINATE SYSTEM: UTM ZONE 20 NORTHERN HEMISPHERE.
 2. THE CONTOUR INTERVAL IS 1 METRE.
 3. THIS MAP IS PRODUCED AT A NOMINAL SCALE OF 1:15,000 FOR 24x36 (D SIZE) PAPER. ACTUAL SCALE MAY DIFFER ACCORDING TO CHANGES IN PRINTER SETTINGS OR PRINTED PAPER SIZE.

DISCLAIMER
THIS MAP WAS PREPARED BY KNIGHT PIESOLD LTD. FOR THE ACCOUNT OF THE CLIENT LISTED ON THIS DRAWING. THE MATERIAL ON IT REFLECTS KNIGHT PIESOLD'S BEST JUDGEMENT IN THE LIGHT OF THE INFORMATION AVAILABLE TO IT AT THE TIME OF PREPARATION. ANY USE WHICH A THIRD PARTY MAKES OF THIS DRAWING OR ANY RELIANCE ON OR DECISIONS TO BE MADE BASED ON IT, ARE THE RESPONSIBILITY OF SUCH THIRD PARTIES. KNIGHT PIESOLD ACCEPTS NO RESPONSIBILITY FOR DAMAGES, IF ANY, SUFFERED BY THE THIRD PARTY AS A RESULT OF DECISIONS MADE OR ACTIONS BASED ON THIS DRAWING. COPIES RESULTING FROM ELECTRONIC TRANSFER OR REPRODUCTION OF THIS DRAWING ARE UNCONTROLLED AND MAY NOT BE THE MOST RECENT REVISION OF THIS DRAWING.

Knights Piesold
CONSULTING

**ATLANTIC GOLD CORPORATION
FIFTEEN MILE STREAM PROJECT**

LANDFORM MAP

SAVED: M:\110100708\02\GIS\Drawings\FM-401-TerrainHazards_RA.mxd, Mar 06 2018 10:50 AM kkraszova

DRG. NO.	DESCRIPTION	REV	DATE	DESIGN	DRAWN	CHKD	APPD	REV	DATE	DESCRIPTION	DESIGN	DRAWN	REVIEWED	APPROVED
	REFERENCE DRAWINGS									ISSUED FOR INFORMATION				
										REVISIONS				
										REVISIONS				

P/A NO. VA101-708/2	DRAWING NO. FM-401	REVISION A	
------------------------	-----------------------	---------------	--